

Spezifikation
Spannzangen



FABRY AG

SPANNZANGEN-TECHNOLOGIE
CNC-Bearbeitung Drehen Fräsen Schleifen

Spannzangen Typ B6

FAB

Einheitsnummer -

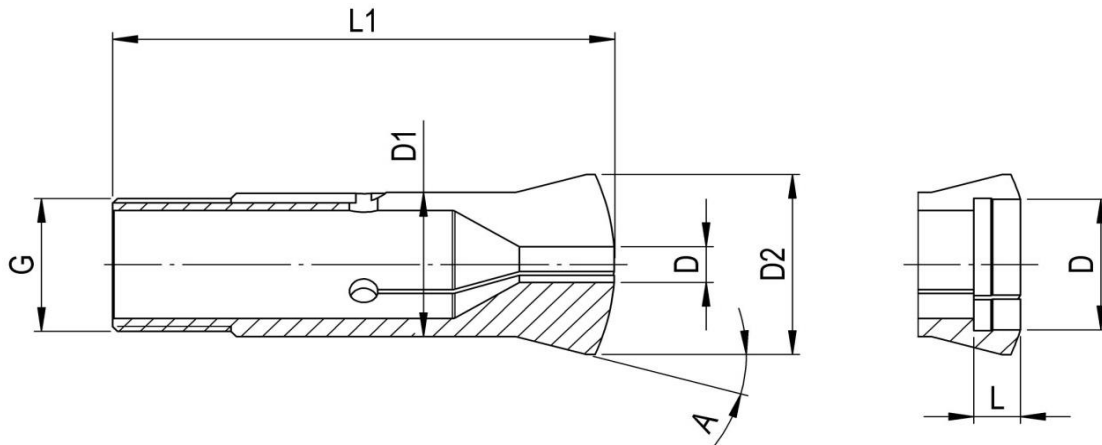

Abmessungen	D1	D2	L1	A	G
B6	6	10.5	31.3	20°	ø5 x 0.706 - 55°

Fabry Bestell Nr:	Alte-Nr.	Bohrung Form	L	Stufung	Bemerkungen
Standard		Rund D			
B6D...	72-00128	ø 00.30...03.00	-	0.1 mm	
		ø 03.50...04.50	12	0.5 mm	
		ø 05.00	4.5	0.5 mm	
Lieferbare Varianten		Rund D			
B6D...	72-00128	ø 00.70...05.00		0.01 mm	

Für grössere Mengen und für andere Ausführungen kontaktieren Sie bitte unseren Verkauf
Tel: +41 61 935 93 00, verkauf@fabry.ch, www.fabry.ch

Spezifikation
Spannzangen



FABRY AG

SPANNZANGEN-TECHNOLOGIE
CNC-Bearbeitung Drehen Fräsen Schleifen

Restposten Spannzangen Typ B6 - B32



Einheitsnummer -

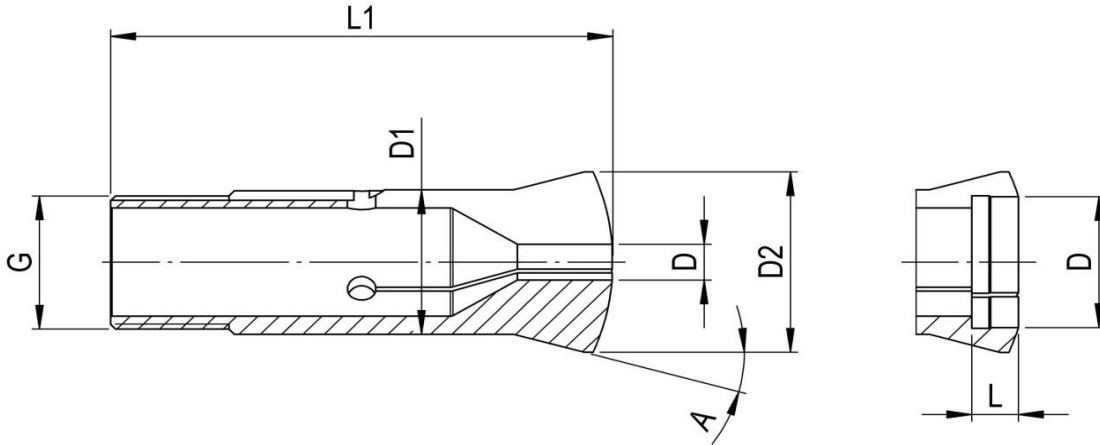

Abmessungen	D1	D2	L1	A	G
B6 (72-01897)	6	9	31.3	20°	5 x 36f / 55°
B23(72-00142)	23	32	88	20°	M 21 x 1
B32(72-00055)	32	40	102	15°	M 30 x 1.5

Fabry Bestell Nr:	Alte-Nr.	Bohrung Form	L	Stufung	Bemerkungen
B6 (72-01897)	72-01897	ø07.00 - ø05.50	Rund	0.1 mm	Restposten
B23(72-00142)	72-00142	ø03.50 - ø22.00	Rund	0.50 mm	Restposten
B32(72-00055)	72-00055	ø01.00 - ø30.00	Rund UP	0.50 mm	Restposten

Für grössere Mengen und für andere Ausführungen kontaktieren Sie bitte unseren Verkauf
Tel: +41 61 935 93 00, verkauf@fabry.ch, www.fabry.ch

Spezifikation
Spannzangen



FABRY AG

SPANNZANGEN-TECHNOLOGIE
CNC-Bearbeitung Drehen Fräsen Schleifen

Spannzangen Typ B8



Einheitsnummer 302E

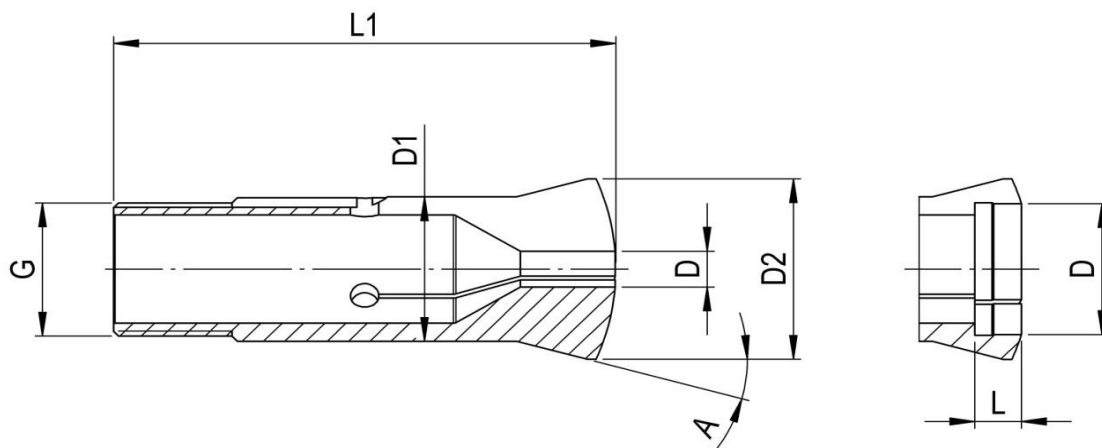

Abmessungen	D1	D2	L1	A	G
B8	8	13	35.5	20°	ø6.82 x 0.625 - 55°

Fabry Bestell Nr:	Alte-Nr.	Bohrung Form	L	Stufung	Bemerkungen
Standard		Rund D			
B8D...	72-00137	ø 00.30...03.00	-	0.1 mm	
		ø 03.00...04.00	-	0.5 mm	
		ø 04.50...06.50	13	0.5 mm	
		ø 06.50...07.00	6	0.5 mm	
		ø 07.50	5	0.5 mm	
		ø 08.00	4	0.5 mm	
Lieferbare Varianten		Rund D			
B8D...	72-00137	ø 00.70...08.00		0.01 mm	

Für grössere Mengen und für andere Ausführungen kontaktieren Sie bitte unseren Verkauf
Tel: +41 61 935 93 00, verkauf@fabry.ch, www.fabry.ch



Schnabelspannzangen Typ B8SL7



Einheitsnummer -

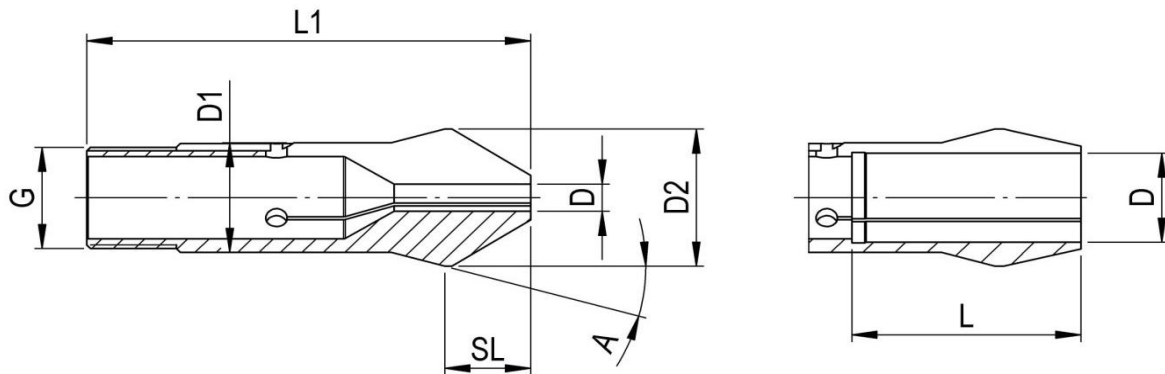

Abmessungen	D1	D2	L1	SL	A	G
B8SL7	8	13	40.5	7	20°	ø6.82 x 0.625 - 55°

Fabry Bestell Nr:	Alte-Nr.	Bohrung Form	L	Stufung	Bemerkungen
Standard		Rund D			
B8SL7D...	72-00095	ø 00.50...03.00	-	0.5 mm	
		ø 04.00...06.00	21	1.0 mm	
Lieferbare Varianten		Rund D			
B8SL7D...	72-00095	ø 00.70...06.00		0.01 mm	

Für grössere Mengen und für andere Ausführungen kontaktieren Sie bitte unseren Verkauf
Tel: +41 61 935 93 00, verkauf@fabry.ch, www.fabry.ch

Spezifikation
Spannzangen



FABRY AG
SPANNZANGEN-TECHNOLOGIE
CNC-Bearbeitung Drehen Fräsen Schleifen

Spannzangen Typ B15



Einheitsnummer 324E

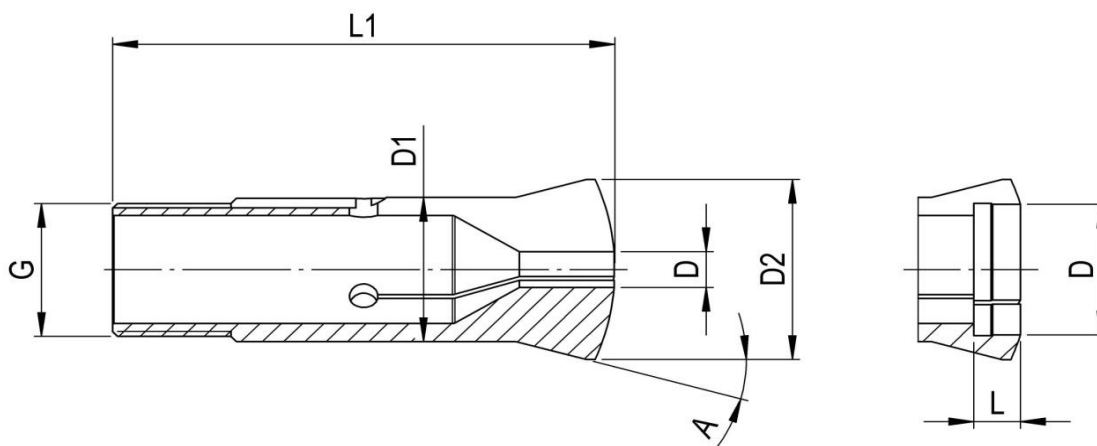

Abmessungen	D1	D2	L1	A	G
B15	15	21	55	20°	M13 x 1

Fabry Bestell Nr:	Alte-Nr.	Bohrung Form	L	Stufung	Bemerkungen
Standard		Rund D			
B15D...	72-00139	ø 01.00...09.50	-	0.5 mm	
		ø 10.00...12.00	20	1.0 mm	
		ø 13.00	8.5	1.0 mm	
		ø 14.00	7	1.0 mm	
		ø 15.00	6	1.0 mm	
Lieferbare Varianten		Rund D			
B15D...	72-00139	ø 01.00...15.00		0.01 mm	

Für grössere Mengen und für andere Ausführungen kontaktieren Sie bitte unseren Verkauf
 Tel: +41 61 935 93 00, verkauf@fabry.ch, www.fabry.ch

Spezifikation
Spannzangen



FABRY AG

SPANNZANGEN-TECHNOLOGIE
CNC-Bearbeitung Drehen Fräsen Schleifen

Spannzangen Typ B32



Einheitsnummer 3713E

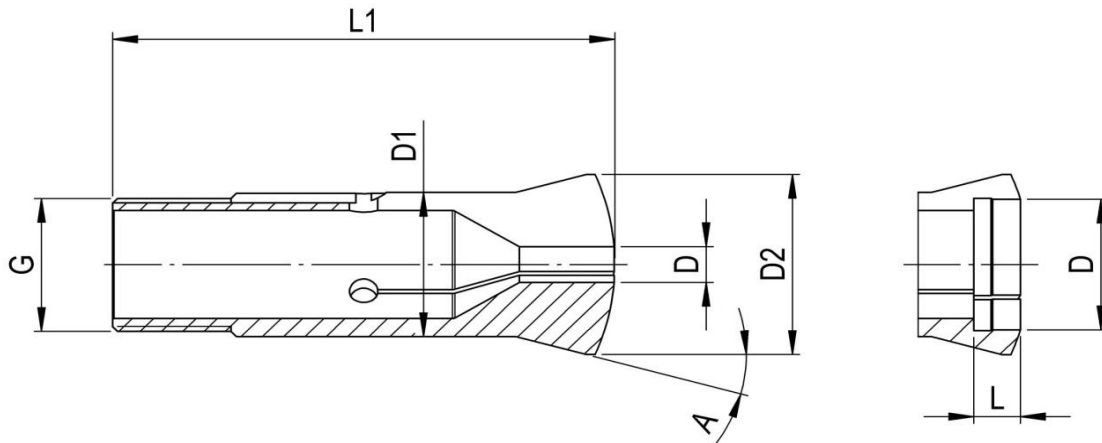

Abmessungen	D1	D2	L1	A	G
B32	32	40	106	15°	ø29.7 x 1.693 - 45°/5°

Fabry Bestell Nr:	Alte-Nr.	Bohrung Form	L	Stufung	Bemerkungen
Standard		Rund D			
B32D...	72-00065	ø 01.00...24.00	-	0.5 mm	
		ø 24.50...28.00	44	0.5 mm	
		ø 28.50...30.00	12	0.5 mm	
		ø 30.50...32.00	8	0.5 mm	
Lieferbare Varianten		Rund D			
B32D...	72-00065	ø 01.00...32.00		0.01 mm	
Standard		Sechskant SK			
B32SK...	72-00065	ø 04.00...20.00	-	1.0 mm	
Lieferbare Varianten		Sechskant SK			
B32SK...	72-00065	ø 04.00...20.00		0.01 mm	
Standard		Vierkant VK			
B32VK...	72-00065	ø 04.00...17.00	-	1.0 mm	
Lieferbare Varianten		Vierkant VK			
B32VK...	72-00065	ø 04.00...17.00		0.01 mm	

Für grössere Mengen und für andere Ausführungen kontaktieren Sie bitte unseren Verkauf
Tel: +41 61 935 93 00, verkauf@fabry.ch, www.fabry.ch



Schnabelspannzangen Typ B32SL24



Einheitsnummer -

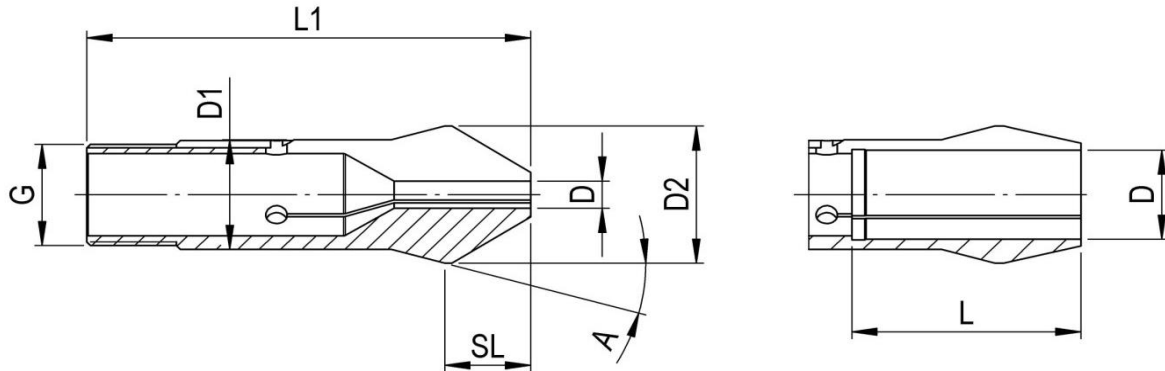

Abmessungen	D1	D2	L1	SL	A	G
B32SL24	32	40	124	24	15°	∅29.7 x 1.693 - 45°/5°

Fabry Bestell Nr:	Alte-Nr.	Bohrung Form	L	Stufung	Bemerkungen
Standard		Rund D			
B32SL24D...	72-02003	∅ 03.00...24.00	-	1.0 mm	
		∅ 25.00	64	1.0 mm	
Lieferbare Varianten		Rund D			
B32SL24D...	72-02003	∅ 03.00...25.00		0.01 mm	

Für grössere Mengen und für andere Ausführungen kontaktieren Sie bitte unseren Verkauf
Tel: +41 61 935 93 00, verkauf@fabry.ch, www.fabry.ch



Restposten Spannzangen Typ BM32



Einheitsnummer -

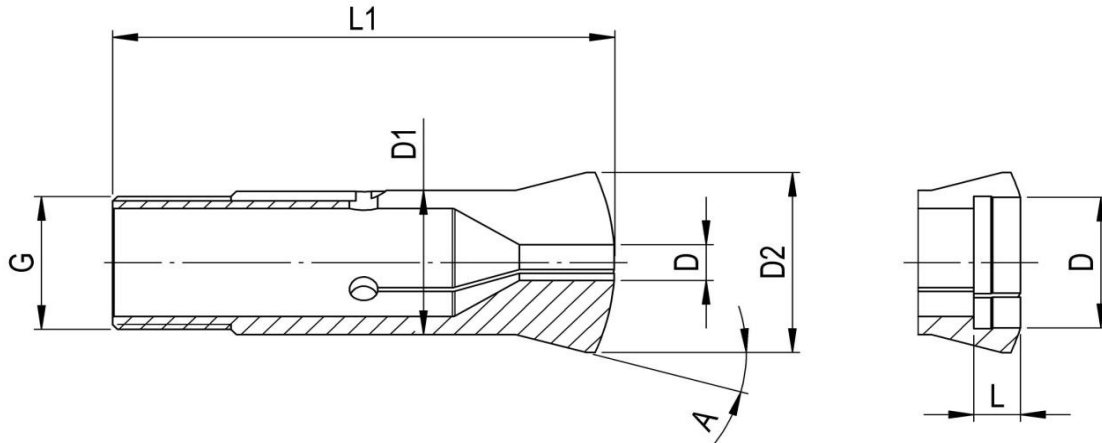

Abmessungen	D1	D2	L1	A	G
BM32	32	40	102	15°	M30 x 1.5

Fabry Bestell Nr:	Alte-Nr.	Bohrung Form	L	Stufung	Bemerkungen
Standard		Rund D			
BM32D...UP	72-00055	ø 01.00...24.00	-	0.5 mm	
		ø 24.50...28.00	44	0.5 mm	
		ø 28.50...30.00	12	0.5 mm	
		ø 30.50...32.00	8	0.5 mm	
Lieferbare Varianten		Rund D			
BM32D...UP	72-00055	ø 01.00...32.00		0.01 mm	

Für grössere Mengen und für andere Ausführungen kontaktieren Sie bitte unseren Verkauf
Tel: +41 61 935 93 00, verkauf@fabry.ch, www.fabry.ch



Schnabelspannzangen Typ B32/45SL32.5



Einheitsnummer -

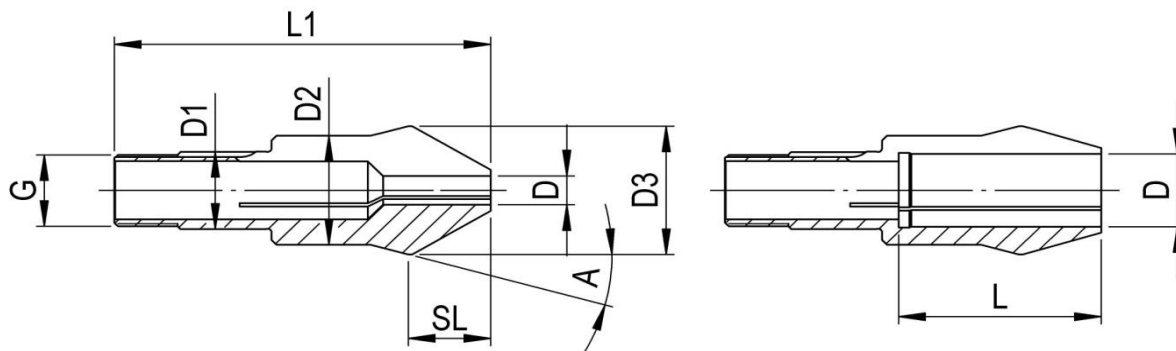

Abmessungen	D1	D2	D3	L1	SL	A	G
B32/45SL32.5	32	45	53	148.5	32.5	15°	ø29.7 x 1.693 - 45°/5°

Fabry Bestell Nr:	Alte-Nr.	Bohrung Form	L	Stufung	Bemerkungen
Standard		Rund D			
B32/45SL32.5D...UP	72-02005	ø 02.00...24.00	-	0.5 mm	
		ø 24.05...40.00	80	0.5 mm	
Lieferbare Varianten		Rund D			
B32/45SL32.5D...UP	72-02005	ø 02.00...40.00		0.01 mm	

Für grössere Mengen und für andere Ausführungen kontaktieren Sie bitte unseren Verkauf
 Tel: +41 61 935 93 00, verkauf@fabry.ch, www.fabry.ch



Spannzangen Typ B45

FAB

Einheitsnummer -

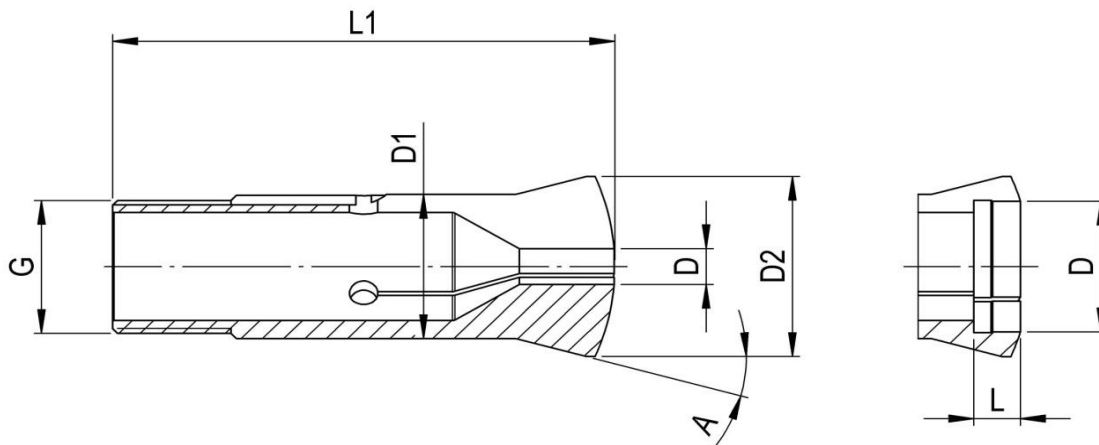

Abmessungen	D1	D2	L1	A	G
B45	45	53	115	15°	M42 x 1.5

Fabry Bestell Nr:	Alte-Nr.	Bohrung Form	L	Stufung	Bemerkungen
Standard		Rund D			
B45D...	72-00199	ø 01.00...36.00	-	1.0 mm	
		ø 37.00...40.00	53	1.0 mm	
		ø 41.00	14	1.0 mm	
		ø 42.00	12	1.0 mm	
		ø 43.00	10	1.0 mm	
		ø 44.00	8	1.0 mm	
Lieferbare Varianten		Rund D			
B45D...	72-00199	ø 01.00...44.00		0.01 mm	

Für grössere Mengen und für andere Ausführungen kontaktieren Sie bitte unseren Verkauf
Tel: +41 61 935 93 00, verkauf@fabry.ch, www.fabry.ch

Spezifikation
Spannzangen



FABRY AG

SPANNZANGEN-TECHNOLOGIE
CNC-Bearbeitung Drehen Fräsen Schleifen

Spannzangen Typ L20K28

FAB

Einheitsnummer 355E

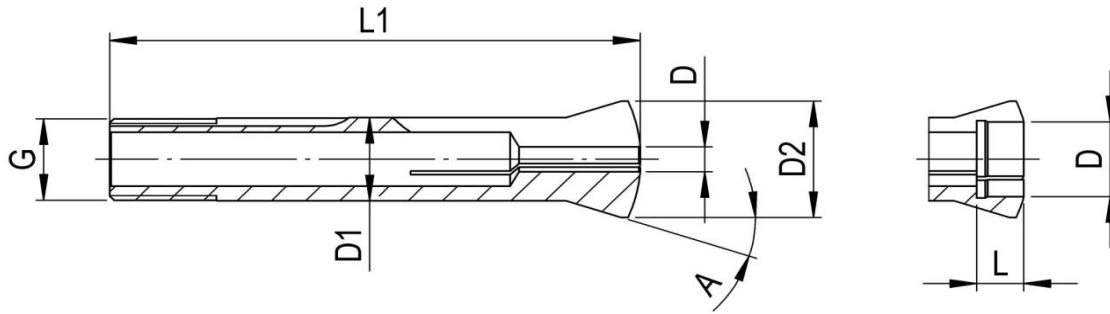

Abmessungen	D1	D2	L1	A	G1
L20K28	ø20	ø28	122	17°30'	ø19.7 x 2.0 - 45°/5°

Fabry Bestell Nr:	Alte-Nr.	Bohrung Form	L	Stufung	Bemerkungen
Standard		Rund D			
L20K28D...	77-00122	ø 01.00...05.00	-	0.5 mm	
		ø 06.00...13.00	-	1.0 mm	
		ø 14.00...17.00	59	1.0 mm	
		ø 18.00	12	1.0 mm	
		ø 19.00	10	1.0 mm	
		ø 20.00	8	1.0 mm	
		ø 21.00	6.5	1.0 mm	
		ø 22.00	4.5	1.0 mm	
Lieferbare Varianten		Rund D			
L20K28D...	77-00122	ø 01.00...22.00		0.01 mm	

Für grössere Mengen und für andere Ausführungen kontaktieren Sie bitte unseren Verkauf
Tel: +41 61 935 93 00, verkauf@fabry.ch, www.fabry.ch



Restposten Spannzangen Typ L20K27.5



Einheitsnummer -

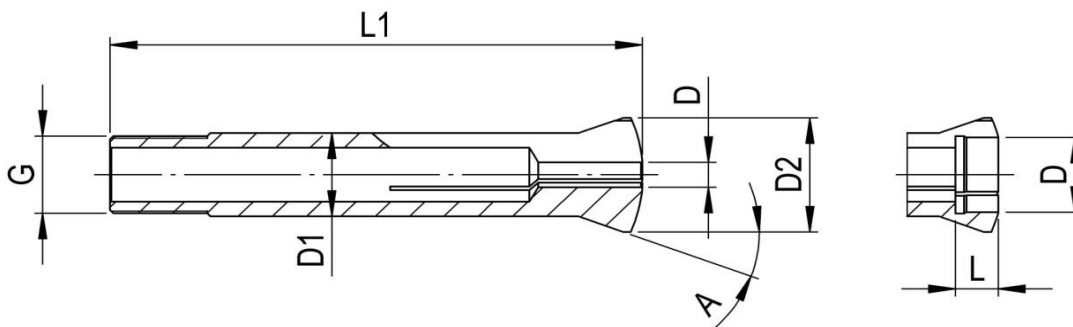

Abmessungen	D1	D2	L1	A	G1
L20K27.5	ø20	ø27.5	122	20°	ø18.5 x 1.4 - 50°

Fabry Bestell Nr:	Alte-Nr.	Bohrung Form	L	Stufung	Bemerkungen
Standard		Rund D			
L20K27.5D...	77-00826	ø 02.00...13.00	-	0.5 mm	Restposten
		ø 13.50...18.00	59	0.5 mm	Restposten
		ø 18.50	11	0.5 mm	Restposten
		ø 19.00	10	0.5 mm	Restposten
		ø 19.50	9	0.5 mm	Restposten
		ø 20.00	8	0.5 mm	Restposten
Lieferbare Varianten		Rund D			
L20K27.5D...	77-00826	ø 02.00...20.00		0.01 mm	

Für grössere Mengen und für andere Ausführungen kontaktieren Sie bitte unseren Verkauf
 Tel: +41 61 935 93 00, verkauf@fabry.ch, www.fabry.ch



Restposten Spannzangen Typ P3 - P16



Einheitsnummer -

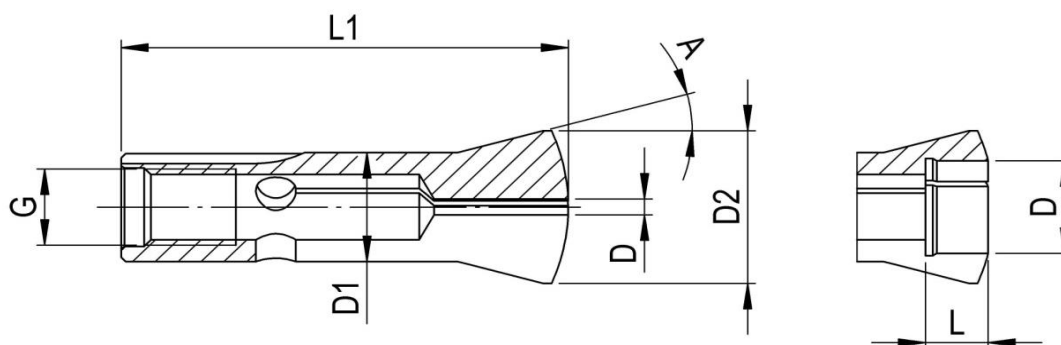

Abmessungen	D1	D2	L1	A	G	
P3	ø3	ø4.5	19	15°	M2.5x04	
P4	ø4	ø6	15.8	20°	M2.5x04	
P4.5	ø4.5	ø6.75	22.5	15°	M3	
P16	ø16	ø22	75	15°	M8	

Fabry Bestell Nr:	Alte-Nr.	Bohrung Form	L	Stufung	Bemerkungen
Standard		Rund D			
P3D...	78-00218	ø 02.10...02.50	-	0.1 mm	Restposten
P4D...	78-00152	ø 01.00...03.00	-	0.1 mm	Restposten
P4.5D...	78-00158	ø 00.50...01.60	-	0.1 mm	Restposten
P16D...	78-00392	ø 01.00...06.40	-	0.1 mm	Restposten
P16D...	78-00392	ø 06.50...12.00	45	0.1 mm	Restposten

Für grössere Mengen und für andere Ausführungen kontaktieren Sie bitte unseren Verkauf
Tel: +41 61 935 93 00, verkauf@fabry.ch, www.fabry.ch

**Spezifikation
Spannzangen**



Spannzangen Typ P4.5

FAB

Einheitsnummer -

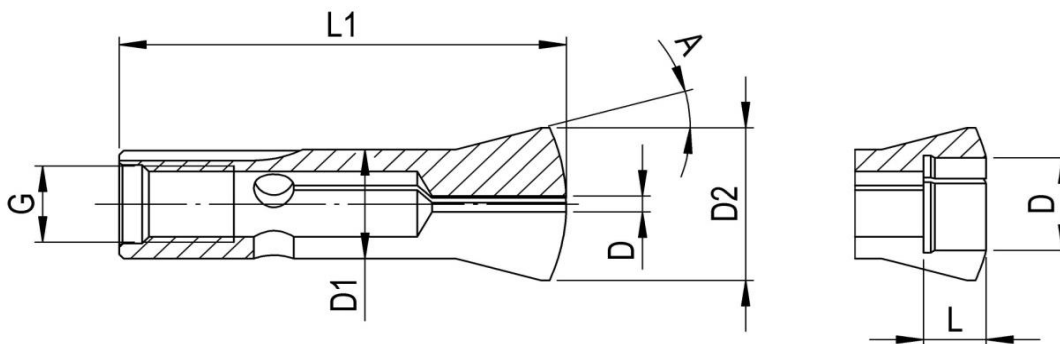

Abmessungen	D1	D2	L1	A	G	
P4.5	ø4.5	ø6.75	22.9	15°	M3.35	

Fabry Bestell Nr:	Alte-Nr.	Bohrung Form	L	Stufung	Bemerkungen
P4.5D...	78-00153	ø 00.20...02.50	-	0.1 mm	
		ø 02.60...03.00	8.5	0.1 mm	
		ø 03.10...04.00	4	0.1 mm	
		ø 04.10...04.50	3	0.1 mm	
Lieferbare Varianten		Rund D			
P4.5D...	78-00153	ø 00.70...04.50		0.01 mm	

Für grössere Mengen und für andere Ausführungen kontaktieren Sie bitte unseren Verkauf
 Tel: +41 61 935 93 00, verkauf@fabry.ch, www.fabry.ch



Spannzangen Typ P5



Einheitsnummer -

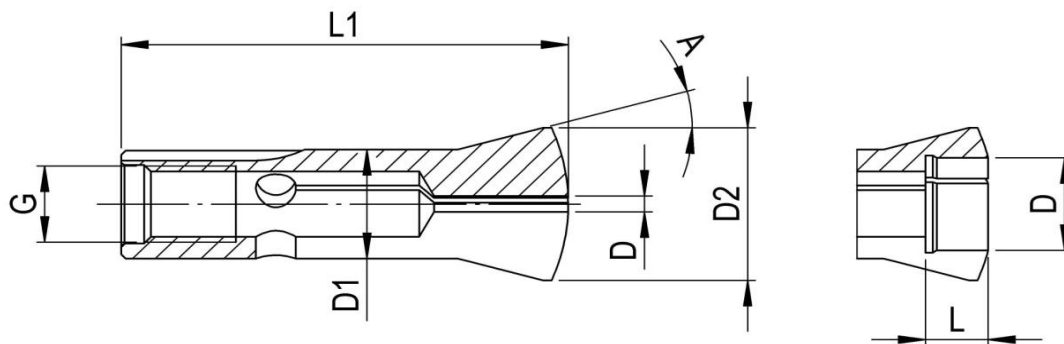

Abmessungen	D1	D2	L1	A	G
P5	ø5	ø7	22.9	15°	M3.5

Fabry Bestell Nr:	Alte-Nr.	Bohrung Form	L	Stufung	Bemerkungen
P5D...	78-00154	ø 00.20...01.50	-	0.1 mm	
		ø 02.00...02.50	-	0.5 mm	
		ø 03.00...03.50	8.5	0.5 mm	
		ø 04.00	4	0.5 mm	
		ø 04.50	3	0.5 mm	
		ø 05.00	2	0.5 mm	
Lieferbare Varianten		Rund D			
P5D...		ø 00.70...05.00		0.01 mm	

Für grössere Mengen und für andere Ausführungen kontaktieren Sie bitte unseren Verkauf
Tel: +41 61 935 93 00, verkauf@fabry.ch, www.fabry.ch

Spezifikation
Spannzangen



FABRY AG

SPANNZANGEN-TECHNOLOGIE
CNC-Bearbeitung Drehen Fräsen Schleifen

Spannzangen Typ P6

FAB

Einheitsnummer -

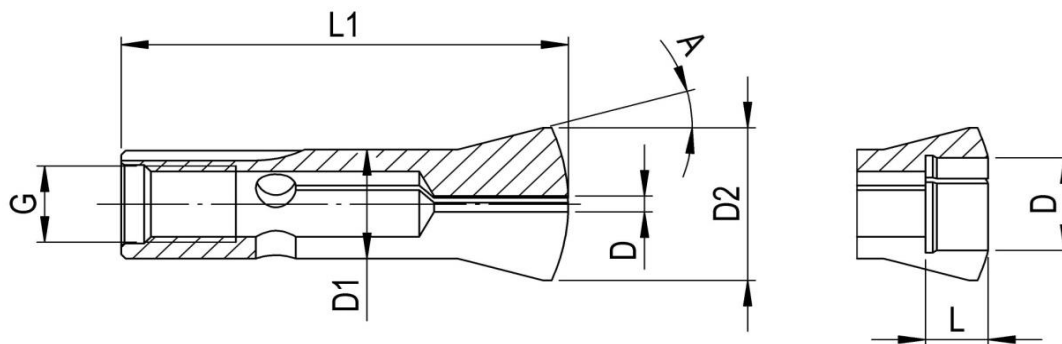

Abmessungen	D1	D2	L1	A	G
P6	ø6	ø8.5	27.2	15°	M4

Fabry Bestell Nr:	Alte-Nr.	Bohrung Form	L	Stufung	Bemerkungen
P6D...	78-00150	ø 00.40...02.00	-	0.1 mm	
		ø 02.50...03.00	-	0.5 mm	
		ø 03.50...04.50	11.5	0.5 mm	
		ø 05.00	4.5	0.5 mm	
Lieferbare Varianten		Rund D			
P6D...	78-00150	ø 00.70...05.00		0.01 mm	

Für grössere Mengen und für andere Ausführungen kontaktieren Sie bitte unseren Verkauf
Tel: +41 61 935 93 00, verkauf@fabry.ch, www.fabry.ch

Spezifikation
Spannzangen



FABRY AG
SPANNZANGEN-TECHNOLOGIE
CNC-Bearbeitung Drehen Fräsen Schleifen

Spannzangen Typ P9

FAB

Einheitsnummer -

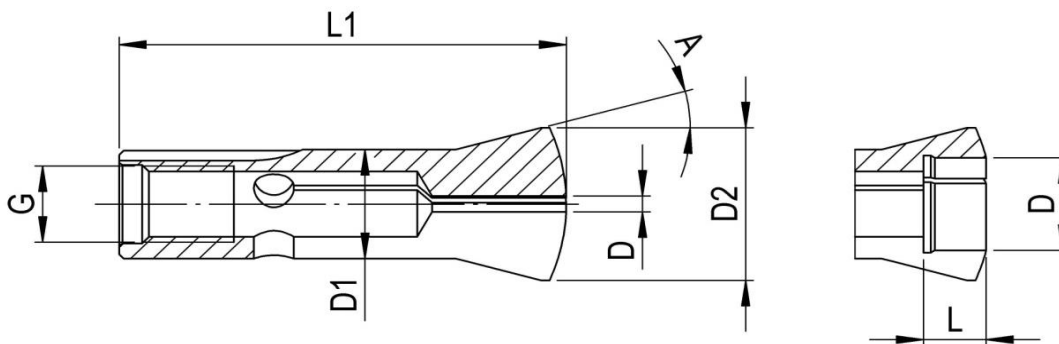

Abmessungen	D1	D2	L1	A	G	
P9	ø9	ø13.2	39.3	15°	M6	

Fabry Bestell Nr:	Alte-Nr.	Bohrung Form	L	Stufung	Bemerkungen
P9D...	78-00157	ø 00.50...02.00	-	0.1 mm	
		ø 02.50...04.50	-	0.5 mm	
		ø 05.00...07.00	12	0.5 mm	
		ø 07.50...08.00	7	0.5 mm	
		ø 08.50...09.00	5	0.5 mm	
Lieferbare Varianten		Rund D			
P9D...		ø 00.70...09.00		0.01 mm	

Für grössere Mengen und für andere Ausführungen kontaktieren Sie bitte unseren Verkauf
Tel: +41 61 935 93 00, verkauf@fabry.ch, www.fabry.ch



Spannzangen Typ P10



Einheitsnummer -

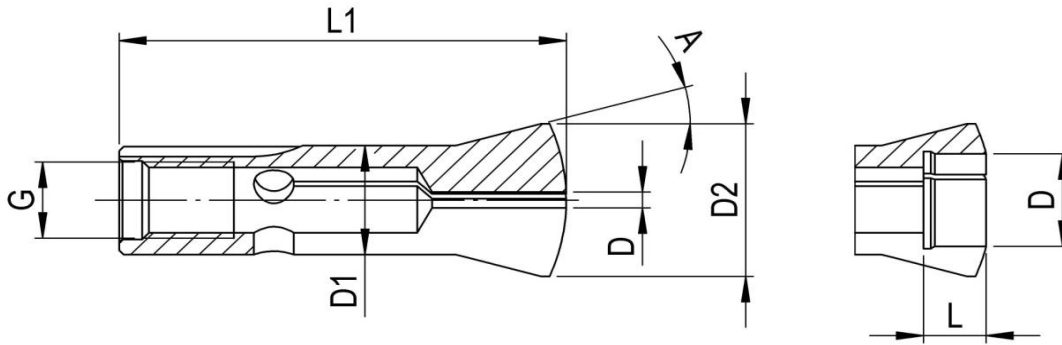

Abmessungen	D1	D2	L1	A	G
P10	ø10	ø14	39	15°	M7

Fabry Bestell Nr:	Alte-Nr.	Bohrung Form	L	Stufung	Bemerkungen
P10D...	78-00228	ø 00.50...05.50	-	0.5 mm	
		ø 06.00...08.00	21.5	1.0 mm	
		ø 09.00	5	1.0 mm	
		ø 10.00	3	1.0 mm	
Lieferbare Varianten		Rund D			
P10D...	78-00228	ø 00.70...10.00		0.01 mm	

Für grössere Mengen und für andere Ausführungen kontaktieren Sie bitte unseren Verkauf
Tel: +41 61 935 93 00, verkauf@fabry.ch, www.fabry.ch

Spezifikation
Spannzangen



FABRY AG
SPANNZANGEN-TECHNOLOGIE
CNC-Bearbeitung Drehen Fräsen Schleifen

Spannzangen Typ P25 / P36



Einheitsnummer -

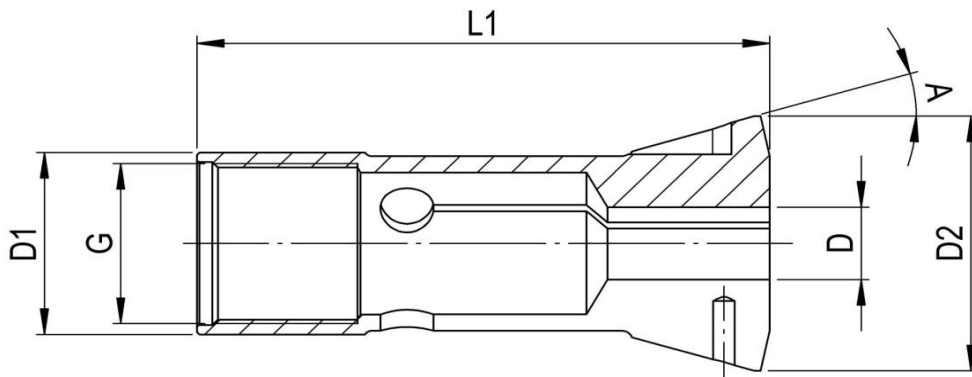

Abmessungen	D1	D2	L1	A	G	
P25	ø25	ø35	75	16°	M22x1	
P36	ø36	ø45	107	16°	M33x1.25	

Fabry Bestell Nr:	Alte-Nr.	Bohrung Form	Stufung	Bemerkungen
Standard		Rund D		
P25D...	78-00334	ø 03.00...15.00	0.5 mm	
P36D...	78-02007	ø 03.00...21.00	0.5 mm	
Lieferbare Varianten		Rund D		
P25D...	78-00334	ø 03.00...15.00	0.01 mm	
P36D...	78-02007	ø 03.00...21.00	0.01 mm	

Für grössere Mengen und für andere Ausführungen kontaktieren Sie bitte unseren Verkauf
Tel: +41 61 935 93 00, verkauf@fabry.ch, www.fabry.ch

Spezifikation
Spannzangen



FABRY AG

SPANNZANGEN-TECHNOLOGIE
CNC-Bearbeitung Drehen Fräsen Schleifen

Restposten Spannzangen Typ W8 - W20

FABRY

Einheitsnummer -

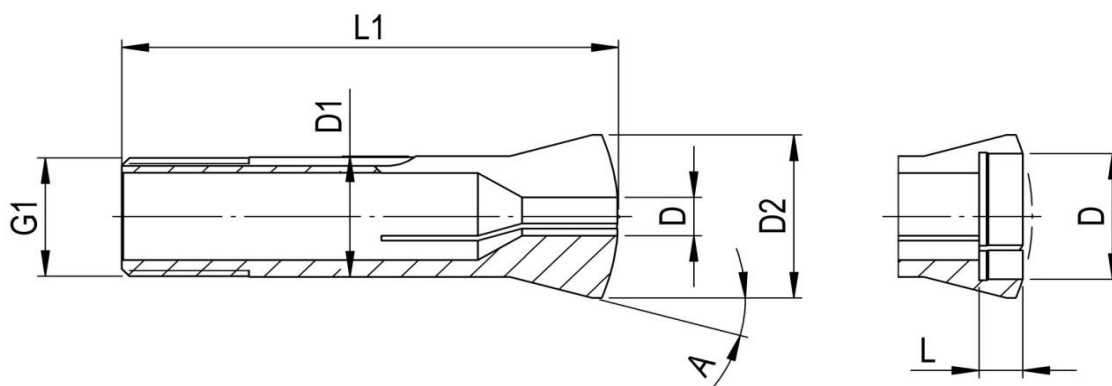

Abmessungen	D1	D2	L1	A	G1	
W8(80-01001)	8	10.85	33	10°	M8x0.75	Kopf 6-Kant SW6
W10(80-01509)	10	14	34	15°	M6x0.75	Kopf 4-Kant SW11
W16(80-00653)	16	22	61	15°	15.9x1.25 45°/5°	
W16.5(80-00586)	16.5	21.5	71	12°	16.3x26 60°	
W20(80-00111)	20	27	80	15°	19.75x2 45°/5°	

Fabry Bestell Nr:	Alte-Nr.	Bohrung Form	L	Stufung	Bemerkungen
Standard		Rund D			
W8(80-01001)	80-01001	ø1.00 - 05.50	-	0.5 mm	Restposten
W10(80-01509)	80-01509	ø2.00 - 05.00	-	0.5 mm	Restposten
W10(80-01509)	80-01509	ø5.50 - 08.00	18	0.5 mm	Restposten
W16(80-00653)	80-00653	ø1.00 - 12.00	-	0.5 mm	Restposten
W16(80-00653)	80-00653	ø12.50 - 14.00	5.5	0.5 mm	Restposten
W16.5(80-00586)	80-00586	ø1.50 - 13.00	-	0.5 mm	Restposten
W20(80-00111)	80-00111	ø00.50 - 14.50	-	0.5 mm	Restposten
W20(80-00111)	80-00111	ø15.00 - 19.50	7.5	0.5 mm	Restposten

Für grössere Mengen und für andere Ausführungen kontaktieren Sie bitte unseren Verkauf

Tel: +41 61 935 93 00, verkauf@fabry.ch, www.fabry.ch

Spezifikation
Spannzangen



FABRY AG
SPANNZANGEN-TECHNOLOGIE
CNC-Bearbeitung Drehen Fräsen Schleifen

Spannzangen Typ W10



Einheitsnummer 314E

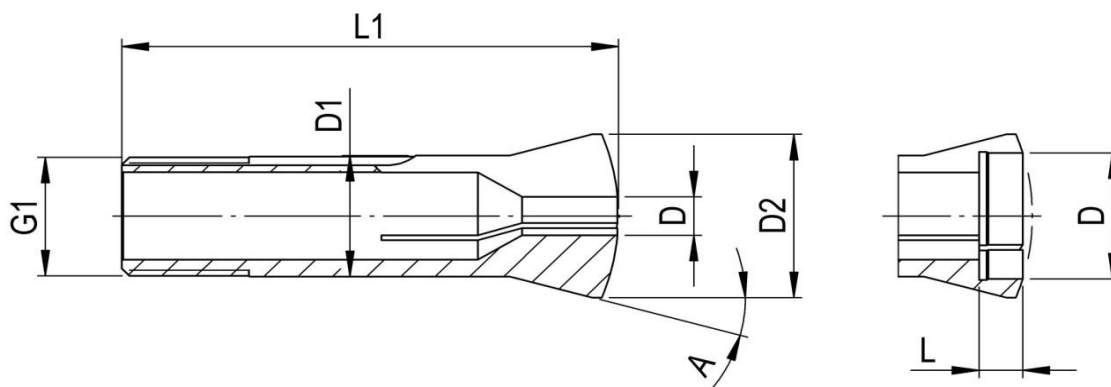

Abmessungen	D1	D2	L1	A	G1
W10	ø10	ø14	43.6	15°	ø9.83 x 0.833 - 45°/5°

Fabry Bestell Nr:	Alte-Nr.	Bohrung Form	L	Stufung	Bemerkungen
Standard		Rund D			
W10D...	80-00001	ø 01.00...03.00	-	0.1 mm	
		ø 03.50...06.50	-	0.5 mm	
		ø 07.00...08.00	15	0.5 mm	
		ø 08.50	6	0.5 mm	
		ø 09.00	5	0.5 mm	
		ø 09.50	4	0.5 mm	
		ø 10.00	3	0.5 mm	
Lieferbare Varianten		Rund D			
W10D...	80-00001	ø 01.00...10.00		0.01 mm	

Für grössere Mengen und für andere Ausführungen kontaktieren Sie bitte unseren Verkauf
Tel: +41 61 935 93 00, verkauf@fabry.ch, www.fabry.ch

Spezifikation
Spannzangen



FABRY AG
SPANNZANGEN-TECHNOLOGIE
CNC-Bearbeitung Drehen Fräsen Schleifen

Spannzangen Typ W12

FAB

Einheitsnummer 318E

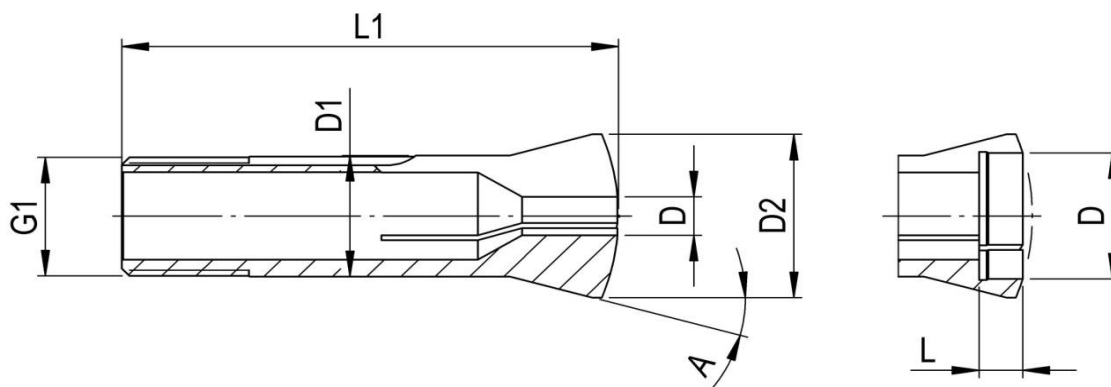

Abmessungen	D1	D2	L1	A	G1
W12	ø12	ø16	46	15°	ø11.75 x 1.25 - 45°/5°

Fabry Bestell Nr:	Alte-Nr.	Bohrung Form	L	Stufung	Bemerkungen
Standard		Rund D			
W12D...	80-00002	ø 00.30...02.90	-	0.1 mm	
		ø 03.00...08.00	-	0.5 mm	
		ø 08.50...10.00	17	0.5 mm	
		ø 10.50	6	0.5 mm	
		ø 11.00	5	0.5 mm	
		ø 11.50	4	0.5 mm	
		ø 12.00	3	0.5 mm	
		ø 12.50	2	0.5 mm	
Lieferbare Varianten		Rund D			
W12D...	80-00002	ø 00.70...12.50		0.01 mm	

Für grössere Mengen und für andere Ausführungen kontaktieren Sie bitte unseren Verkauf
Tel: +41 61 935 93 00, verkauf@fabry.ch, www.fabry.ch

Spezifikation
Spannzangen



FABRY AG
 SPANNZANGEN-TECHNOLOGIE
 CNC-Bearbeitung Drehen Fräsen Schleifen

Schnabelspannzangen Typ W12SL8.8

FB

Einheitsnummer -

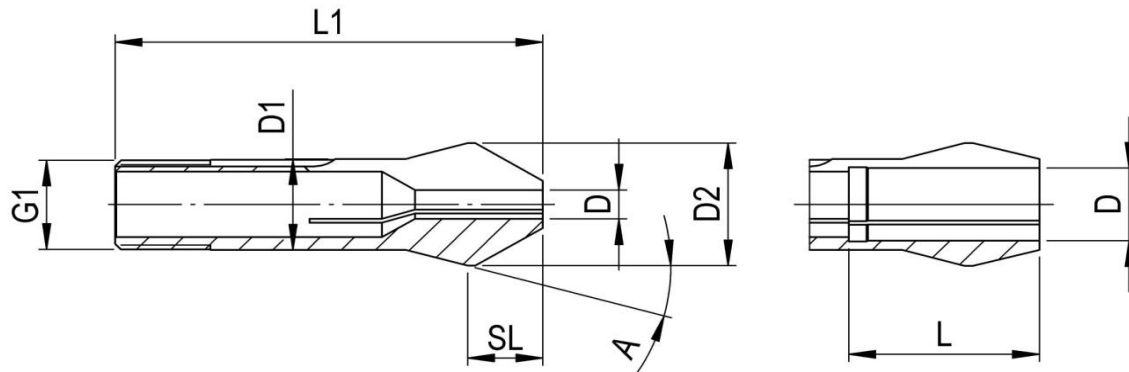

Abmessungen	D1	D2	L1	SL	A	G1	
W12SL8.8	ø12	ø16	52	8.8	15°	ø11.75 x 1.25 - 45°/5°	

Fabry Bestell Nr:	Alte-Nr.	Bohrung Form	L	Stufung	Bemerkungen
Standard		Rund D			
W12SL8.8D...	80-93108	ø 00.50...08.00	-	0.5 mm	
		ø 08.50...10.00	24	0.5 mm	
Lieferbare Varianten		Rund D			
W12SL8.8D...	80-93108	ø 00.70...10.00		0.01 mm	

Für grössere Mengen und für andere Ausführungen kontaktieren Sie bitte unseren Verkauf
 Tel: +41 61 935 93 00, verkauf@fabry.ch, www.fabry.ch

Spezifikation
Spannzangen



FABRY AG
SPANNZANGEN-TECHNOLOGIE
CNC-Bearbeitung Drehen Fräsen Schleifen

Spannzangen Typ W15



Einheitsnummer 321E

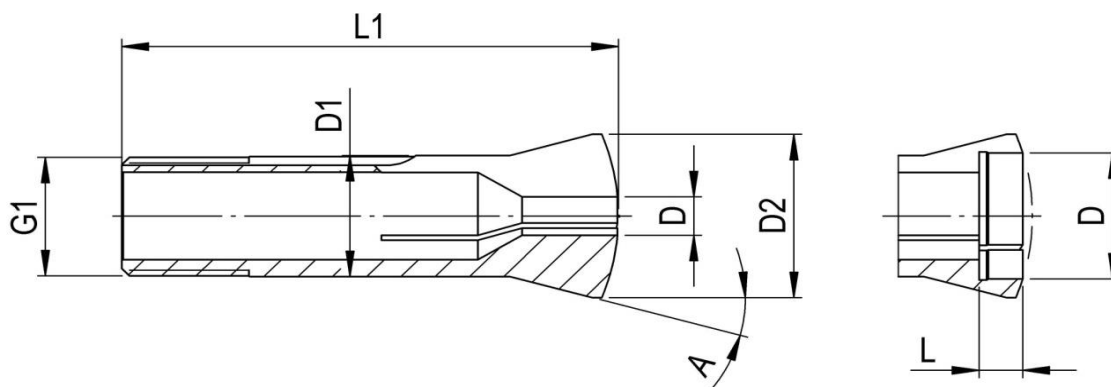

Abmessungen	D1	D2	L1	A	G1
W15	ø15	ø20.2	58.3	15°	ø14.75 x 1.25 - 45°/5°

Fabry Bestell Nr:	Alte-Nr.	Bohrung Form	L	Stufung	Bemerkungen
Standard		Rund D			
W15D...	80-00003	ø 00.50...02.90	-	0.1 mm	
		ø 03.00...10.50	-	0.5 mm	
		ø 11.00...12.50	22	0.5 mm	
		ø 13.00	9.5	0.5 mm	
		ø 13.50	8.5	0.5 mm	
		ø 14.00	7.5	0.5 mm	
		ø 14.50	6.5	0.5 mm	
		ø 15.00	5.5	0.5 mm	
		ø 15.50	4.5	0.5 mm	
		ø 16.00	3.5	0.5 mm	
Lieferbare Varianten		Rund D			
W15D...	80-00003	ø 00.70...16.00		0.01 mm	

Für grössere Mengen und für andere Ausführungen kontaktieren Sie bitte unseren Verkauf
Tel: +41 61 935 93 00, verkauf@fabry.ch, www.fabry.ch

Spezifikation
Spannzangen



FABRY AG
SPANNZANGEN-TECHNOLOGIE
CNC-Bearbeitung Drehen Fräsen Schleifen

Spannzangen Typ W20



Einheitsnummer 349E

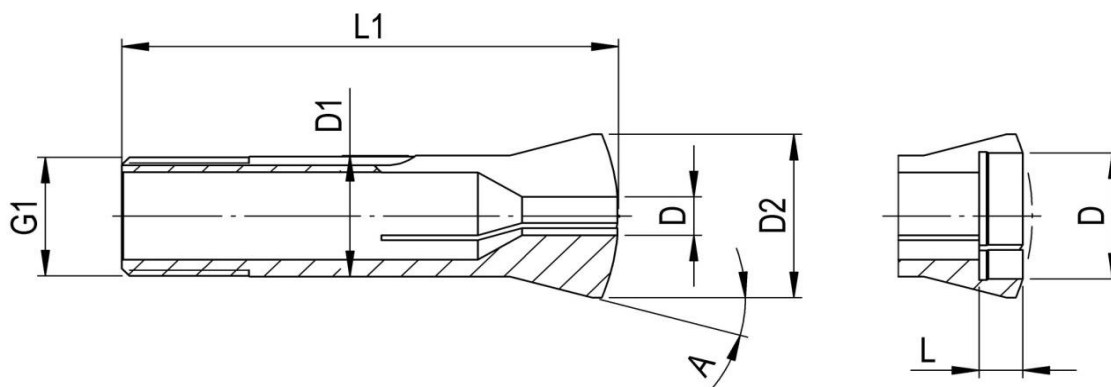

Abmessungen	D1	D2	L1	A	G1
W20	ø20	ø26.3	73	15°	ø19.7 x 1.667 - 45°/5°

Fabry Bestell Nr:	Alte-Nr.	Bohrung Form	L	Stufung	Bemerkungen
Standard		Rund D			
W20D...	80-00004	ø 00.30...03.00	-	0.1 mm	
		ø 03.50...14.50	-	0.5 mm	
		ø 15.00...16.00	28	0.5 mm	
Lieferbare Varianten		Rund D			
W20D...	80-00004	ø 00.70...16.00		0.01 mm	
Standard		Sechskant SK			
W20SK...	80-00004	ø 04.00...16.00		1.0 mm	
Lieferbare Varianten		Sechskant SK			
W20SK...	80-00004	ø 04.00...16.00		0.01 mm	
Standard		Vierkant VK			
W20VK...	80-00004	ø 04.00...14.00		1.0 mm	
Lieferbare Varianten		Vierkant VK			
W20VK...	80-00004	ø 04.00...14.00		0.01 mm	

Für grössere Mengen und für andere Ausführungen kontaktieren Sie bitte unseren Verkauf
Tel: +41 61 935 93 00, verkauf@fabry.ch, www.fabry.ch



Schnabelspannzangen Typ W25SL19.7



Einheitsnummer 364E

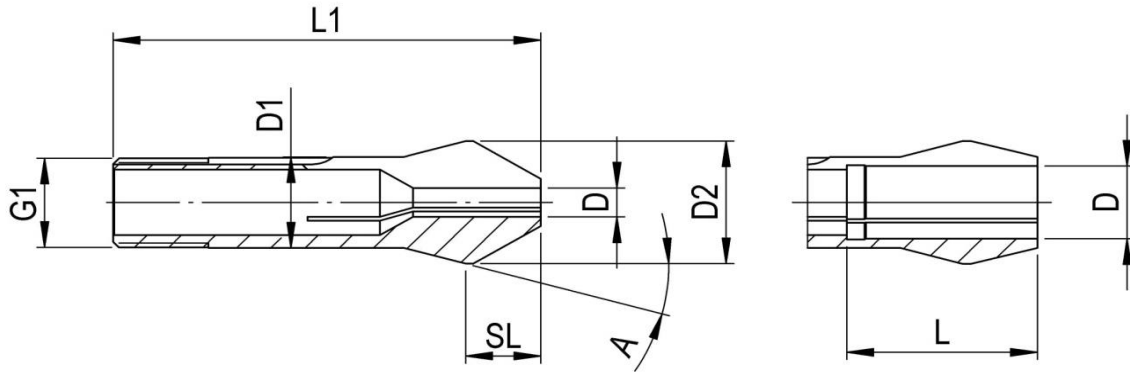

Abmessungen	D1	D2	L1	SL	A	G1	
W25SL19.7	ø25	ø33.7	112.2	19.7	15°	ø24.7 x 1.693 - 45°/5°	

Fabry Bestell Nr:	Alte-Nr.	Bohrung Form	L	Stufung	Bemerkungen
Standard		Rund D			
W25SL19.7D...	80-92872	ø 00.50...19.00	-	0.5 mm	
		ø 19.50...21.00	50	0.5 mm	
Lieferbare Varianten		Rund D			
W25SL19.7D...	80-92872	ø 00.70...21.00		0.01 mm	

Für grössere Mengen und für andere Ausführungen kontaktieren Sie bitte unseren Verkauf
 Tel: +41 61 935 93 00, verkauf@fabry.ch, www.fabry.ch



Schnabelspannzangen Typ W25VSL19.7



Einheitsnummer 364E

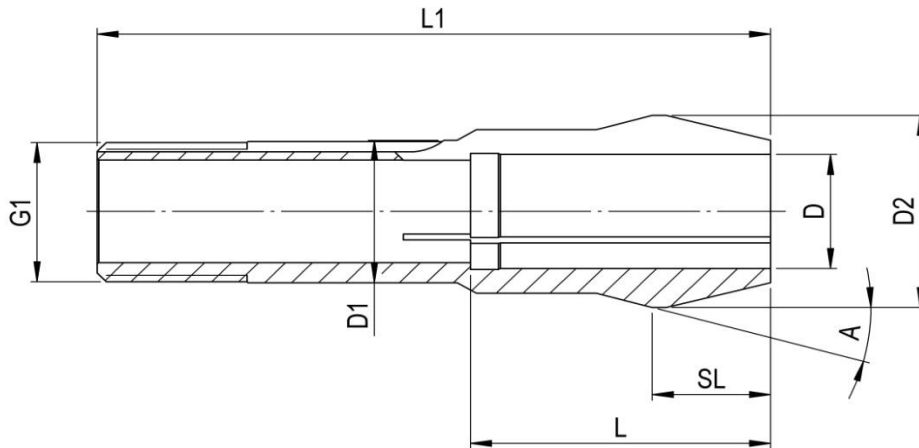

Abmessungen	D1	D2	L1	SL	A	G1
W25VSL19.7	ø25	ø33.7	112.2	19.7	15°	ø24.7 x 1.693 - 45°/5°

Fabry Bestell Nr:	Alte-Nr.	Bohrung Form	L	Stufung	Bemerkungen
Standard		Rund D			
W25VSL19.7D...	80-02006	ø 21.50...25.00	47	0.5 mm	
Lieferbare Varianten		Rund D			
W25VSL19.7D...	80-02006	ø 21.00...25.00		0.01 mm	

Für grössere Mengen und für andere Ausführungen kontaktieren Sie bitte unseren Verkauf
 Tel: +41 61 935 93 00, verkauf@fabry.ch, www.fabry.ch

Spezifikation
Spannzangen



FABRY AG
SPANNZANGEN-TECHNOLOGIE
CNC-Bearbeitung Drehen Fräsen Schleifen

Spannzangen Typ W31.75



Einheitsnummer 385 E

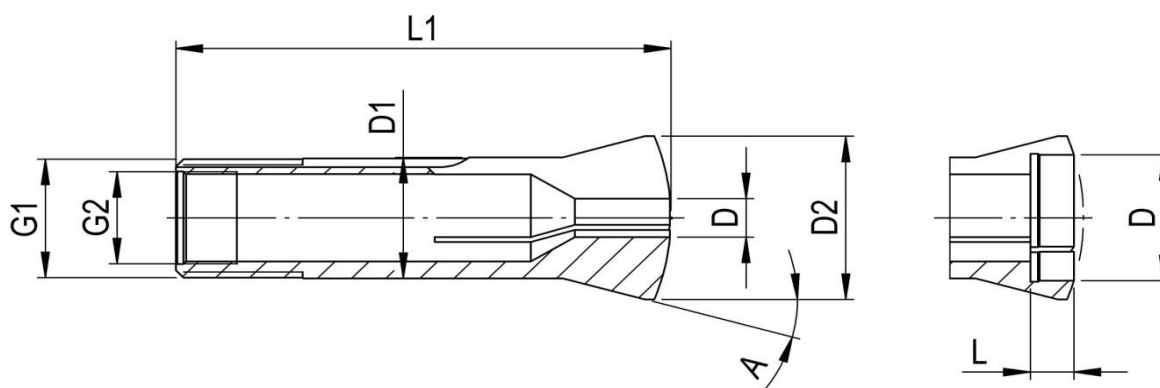

Abmessungen	D1	D2	L1	A	G1	G2
W31.75	ø31.75	ø37.4	87	10°3'	ø31.4x1.27 - 60°	ø26.44x1.058 - 60°

Fabry Bestell Nr:	Alte-Nr.	Bohrung Form	L	Stufung	Bemerkungen
Standard		Rund D			
W31.75D...	80-00842	ø 01.00...25.00	-	0.5 mm	
		ø 25.50...27.50	40	0.5 mm	
		ø 28.00...28.50	10	0.5 mm	
		ø 29.00...29.50	7	0.5 mm	
		ø 30.00...31.00	4	0.5 mm	
Lieferbare Varianten		Rund D			
W31.75D...	80-00842	ø 01.00...31.00		0.01 mm	
W31.75VK...	80-00842	ø 08.00...18.00			auf Anfrage
W31.75SK...	80-00842	ø 08.00...21.00			auf Anfrage

Für grössere Mengen und für andere Ausführungen kontaktieren Sie bitte unseren Verkauf
Tel: +41 61 935 93 00, verkauf@fabry.ch, www.fabry.ch



Schnabelspannzangen Typ W31.75SL25.4



Einheitsnummer 385E

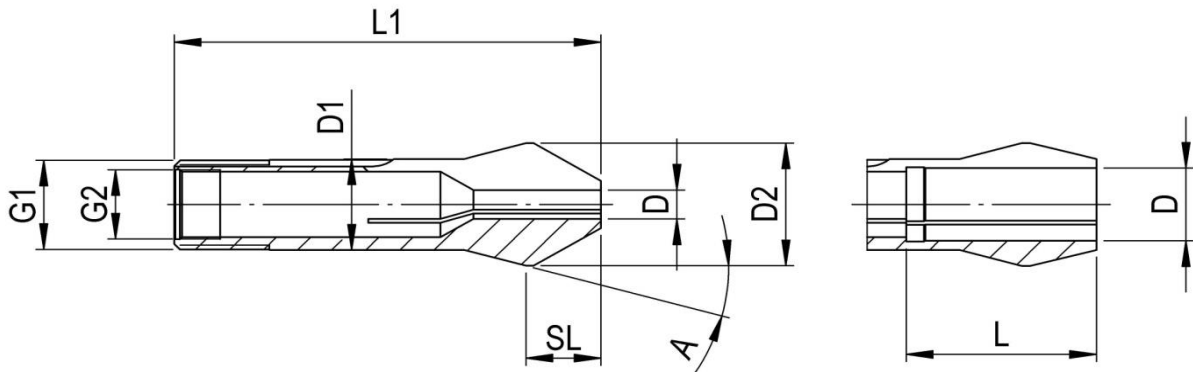

Abmessungen	D1	D2	L1	SL	A	G1	G2
W31.75SL25.4	ø31.75	ø37.4	108.7	25.4	10°3'	ø31.4x1.27 - 60°	ø26.44x1.058 - 60°

Fabry Bestell Nr:	Alte-Nr.	Bohrung Form	L	Stufung	Bemerkungen
Standard		Rund D			
W31.75SL25.4D...	80-02007	ø 02.00...25.00	-	1.0 mm	
		ø 26.00...28.00	64	1.0 mm	
Lieferbare Varianten		Rund D			
W31.75SL25.4D...	80-02007	ø 02.00...28.00		0.01 mm	

Für grössere Mengen und für andere Ausführungen kontaktieren Sie bitte unseren Verkauf
Tel: +41 61 935 93 00, verkauf@fabry.ch, www.fabry.ch