

**Spezifikation
Glockenzangen**



FABRY AG
 SPANNZANGEN-TECHNOLOGIE
 CNC-Bearbeitung Drehen Fräsen Schleifen

Glockenspannzangen Typ F12G



Einheitsnummer -

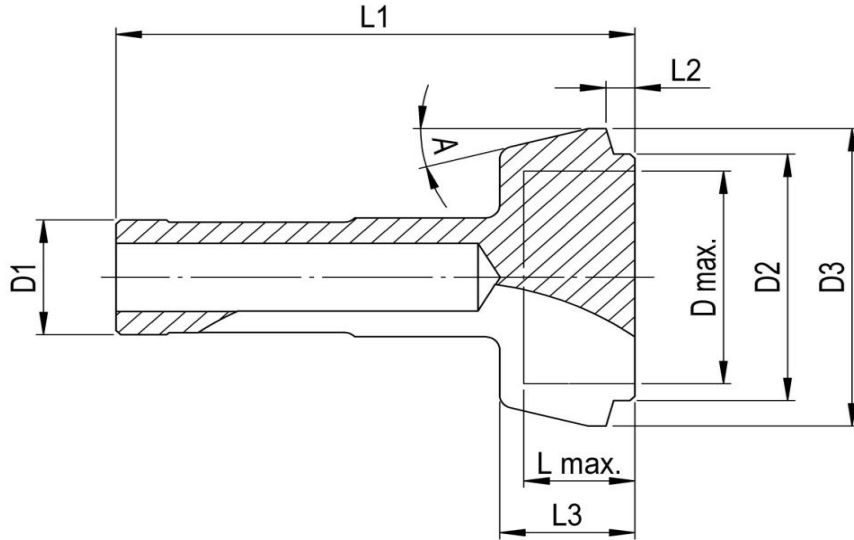

Abmessungen	D1	D2	D3	L1	L2	L3	A	
F12G01	ø12	ø33	ø39	60	5	13	15°	
F12G02	ø12	ø49	ø55	60	5	13	15°	
F12G03	ø12	ø65	ø71	60	5	13	15°	

Fabry Bestell Nr:	Alte-Nr.	L max.	D max.	Bemerkungen
Standard				
F12G01	82-31000	9	ø27	
F12G02	82-31001	9	ø43	
F12G03	82-31002	9	ø59	

Für grössere Mengen und für andere Ausführungen kontaktieren Sie bitte unseren Verkauf
 Tel: +41 61 935 93 00, verkauf@fabry.ch, www.fabry.ch

**Spezifikation
Glockenzangen**



FABRY AG
 SPANNZANGEN-TECHNOLOGIE
 CNC-Bearbeitung Drehen Fräsen Schleifen

Glockenspannzangen Typ F27G



Einheitsnummer -

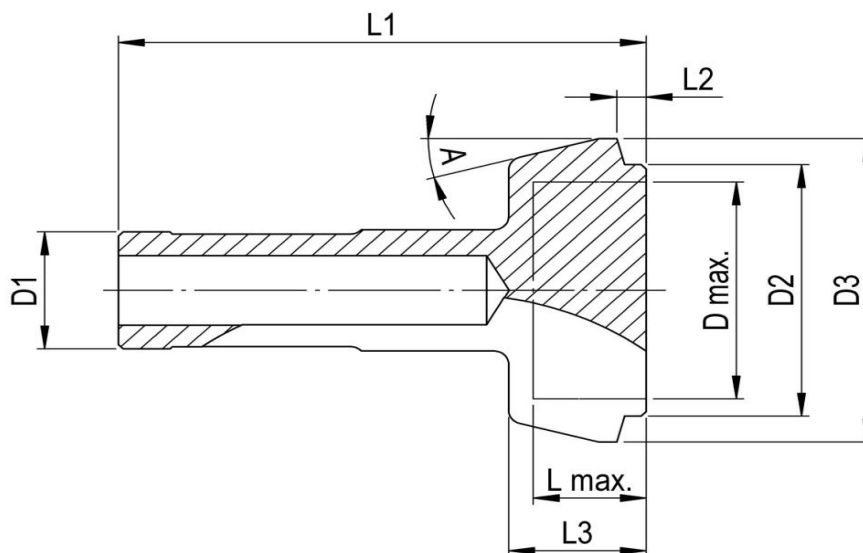

Abmessungen	D1	D2	D3	L1	L2	L3	A	
F27G01	ø27	ø58	ø70	107.5	6	28	15°	
F27G02	ø27	ø88	ø100	107.5	6	28	15°	
F27G03	ø27	ø118	ø130	107.5	6	28	15°	
F27G04	ø27	ø148	ø160	107.5	6	28	15°	

Fabry Bestell Nr:	Alte-Nr.	L max.	D max.	Bemerkungen
Standard				
F27G01	82-31003	23	ø50	
F27G02	82-31004	23	ø80	
F27G03	82-31005	23	ø110	
F27G04	82-31006	23	ø140	

Für grössere Mengen und für andere Ausführungen kontaktieren Sie bitte unseren Verkauf
 Tel: +41 61 935 93 00, verkauf@fabry.ch, www.fabry.ch

**Spezifikation
Glockenzangen**



FABRY AG
 SPANNZANGEN-TECHNOLOGIE
 CNC-Bearbeitung Drehen Fräsen Schleifen

Glockenspannzangen Typ F38G



Einheitsnummer -

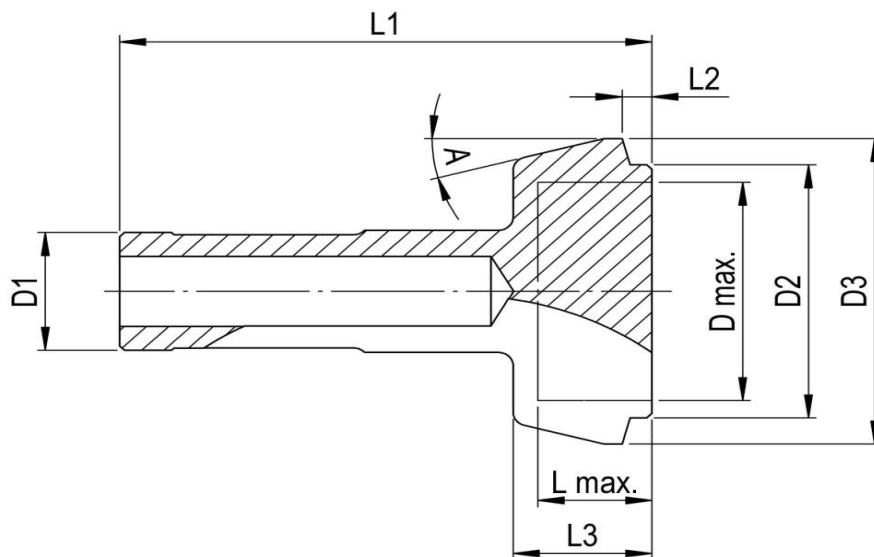

Abmessungen	D1	D2	D3	L1	L2	L3	A	
F38G01	ø38	ø58	ø70	139	6	28	15°	
F38G02	ø38	ø88	ø100	139	6	28	15°	
F38G03	ø38	ø118	ø130	139	6	28	15°	
F38G04	ø38	ø148	ø160	139	6	28	15°	

Fabry Bestell Nr:	Alte-Nr.	L max.	D max.	Bemerkungen
Standard				
F38G01	82-31007	23	ø50	
F38G02	82-31008	23	ø80	
F38G03	82-31009	23	ø110	
F38G04	82-31010	23	ø140	

Für grössere Mengen und für andere Ausführungen kontaktieren Sie bitte unseren Verkauf
 Tel: +41 61 935 93 00, verkauf@fabry.ch, www.fabry.ch

Spezifikation
Glockenzangen



FABRY AG
SPANNZANGEN-TECHNOLOGIE
CNC-Bearbeitung Drehen Fräsen Schleifen

Glockenspannzangen Typ B32G



Einheitsnummer -

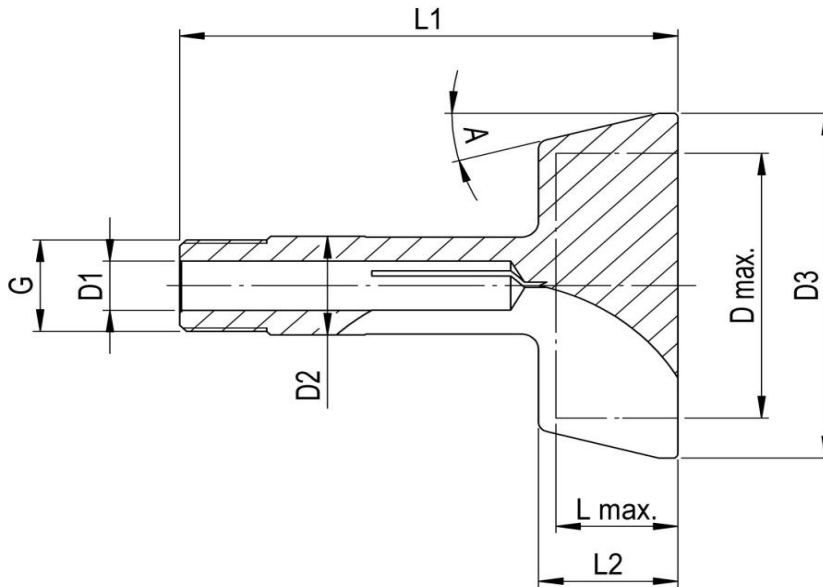

Abmessungen	D1	D2	D3	A	G
B32G01	ø16	ø32	70	15°	ø29.7 x 1.693 - 45°/5°
B32G02	ø16	ø32	112	15°	ø29.7 x 1.693 - 45°/5°
B32G03	ø16	ø32	152	15°	ø29.7 x 1.693 - 45°/5°
B32G04	ø16	ø32	192	15°	ø29.7 x 1.693 - 45°/5°

Fabry Bestell Nr:	Alte-Nr.	L1	L2	L max.	D max.	Bemerkungen
Standard						
B32G01	82-11000	143	40	35	ø44	
B32G02	82-11001	143	40	35	ø86	
B32G03	82-11002	143	40	35	ø126	
B32G04	82-11003	143	40	35	ø166	

Für grössere Mengen und für andere Ausführungen kontaktieren Sie bitte unseren Verkauf
Tel: +41 61 935 93 00, verkauf@fabry.ch, www.fabry.ch

Spezifikation
Glockenspannzangen



FABRY AG
SPANNZANGEN-TECHNOLOGIE
CNC-Bearbeitung Drehen Fräsen Schleifen

Glockenspannzangen Typ W20G01



Einheitsnummer -

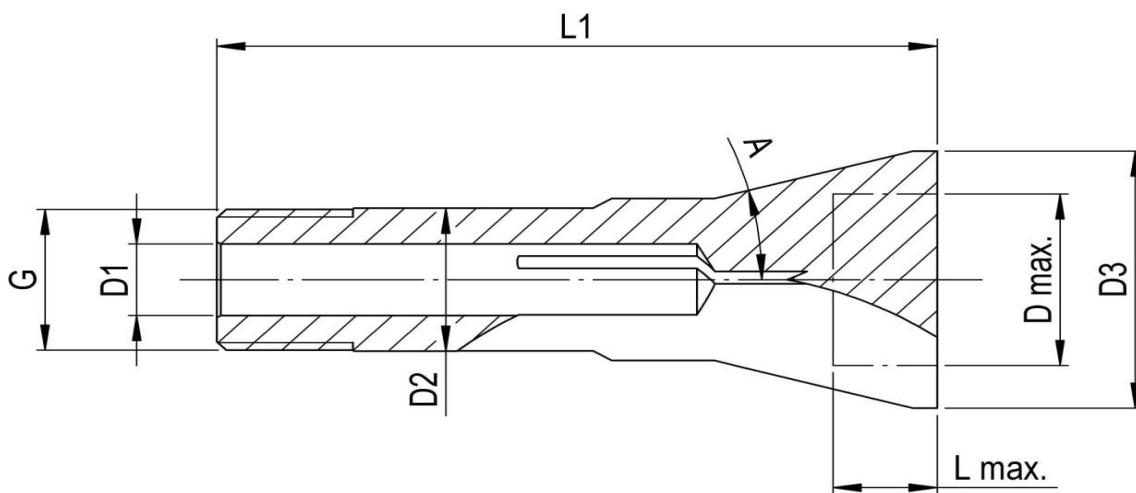

Abmessungen	D1	D2	D3	L1	A	G	
W20G01	ø10	ø20	36	90	15°	ø19.7 x 1.667 - 45°/5°	

Fabry Bestell Nr:	Alte-Nr.	D max.	L max.	Bemerkungen
Standard				
W20G01	82-51000	ø24	13	
W20G01SA4	82-51000	ø24	13	4-Schlitz

Für grössere Mengen und für andere Ausführungen kontaktieren Sie bitte unseren Verkauf
 Tel: +41 61 935 93 00, verkauf@fabry.ch, www.fabry.ch

Spezifikation
Glockenzangen



FABRY AG
SPANNZANGEN-TECHNOLOGIE
CNC-Bearbeitung Drehen Fräsen Schleifen

Glockenspannzangen Typ W12G



Einheitsnummer -

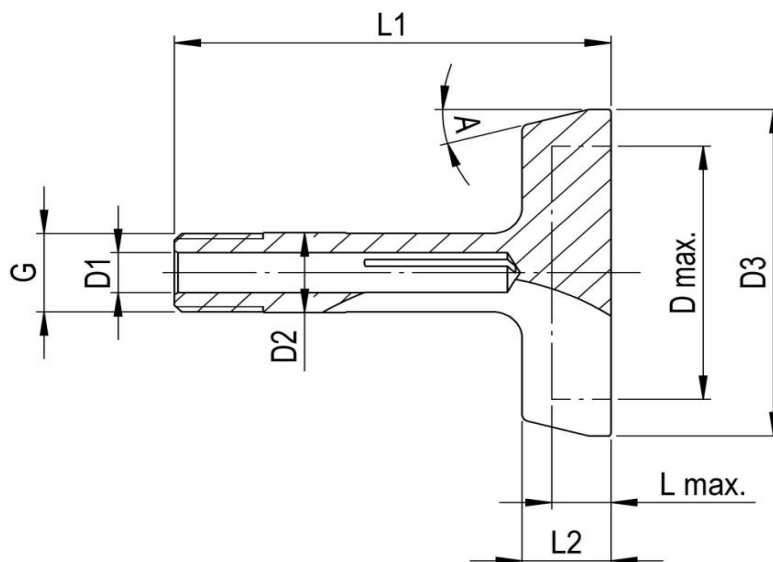

Abmessungen	D1	D2	D3	A	G
W12G01	ø6	ø12	33	15°	ø11.75 x 1.25 - 45°/5°
W12G02	ø6	ø12	49	15°	ø11.75 x 1.25 - 45°/5°
W12G03	ø6	ø12	65	15°	ø11.75 x 1.25 - 45°/5°
W12G04	ø6	ø12	81	15°	ø11.75 x 1.25 - 45°/5°
W12G05	ø6	ø12	97	15°	ø11.75 x 1.25 - 45°/5°

Fabry Bestell Nr:	Alte-Nr.	L1	L2	L max.	D max.	Bemerkungen
Standard						
W12G01	82-51006	59	12	8	ø22	
W12G02	82-51007	59	12	8	ø38	
W12G02SA4	82-51007	59	12	8	ø38	4-Schlitz
W12G03	82-51008	59	12	8	ø54	
W12G04	82-51009	59	12	8	ø70	
W12G05	82-51010	59	12	8	ø86	

Für grössere Mengen und für andere Ausführungen kontaktieren Sie bitte unseren Verkauf
Tel: +41 61 935 93 00, verkauf@fabry.ch, www.fabry.ch



Glockenspannzangen Typ W20G



Einheitsnummer -

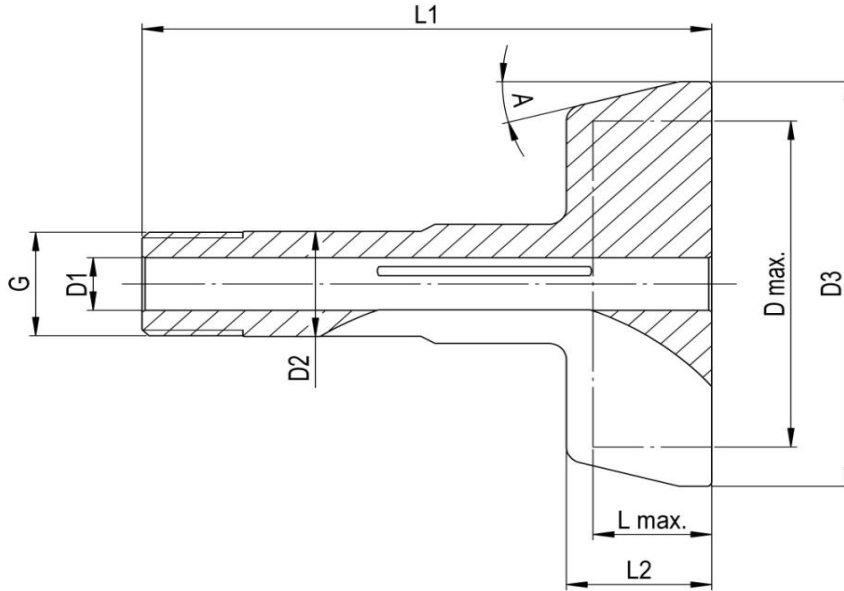

Abmessungen	D1	D2	D3	A	G
W20G02	ø10	ø20	56	15°	ø19.7 x 1.667 - 45°/5°
W20G03	ø10	ø20	77	15°	ø19.7 x 1.667 - 45°/5°
W20G04	ø10	ø20	98	15°	ø19.7 x 1.667 - 45°/5°
W20G05	ø10	ø20	120	15°	ø19.7 x 1.667 - 45°/5°
W20G06	ø10	ø20	140	15°	ø19.7 x 1.667 - 45°/5°

Fabry Bestell Nr:	Alte-Nr.	L1	L2	L max.	D max.	Bemerkungen
Standard						
W20G02	82-51001	96	24.5	20	ø40	
W20G03	82-51002	96	24.5	20	ø62	
W20G04	82-51003	96	24.5	20	ø82	
W20G05	82-51004	96	24.5	20	ø104	
W20G06	82-51005	96	24.5	20	ø124	

Für grössere Mengen und für andere Ausführungen kontaktieren Sie bitte unseren Verkauf
Tel: +41 61 935 93 00, verkauf@fabry.ch, www.fabry.ch

Spezifikation
Glockenzangen



FABRY AG
SPANNZANGEN-TECHNOLOGIE
CNC-Bearbeitung Drehen Fräsen Schleifen

Glockenspannzangen Typ W20G..ZL



Einheitsnummer -

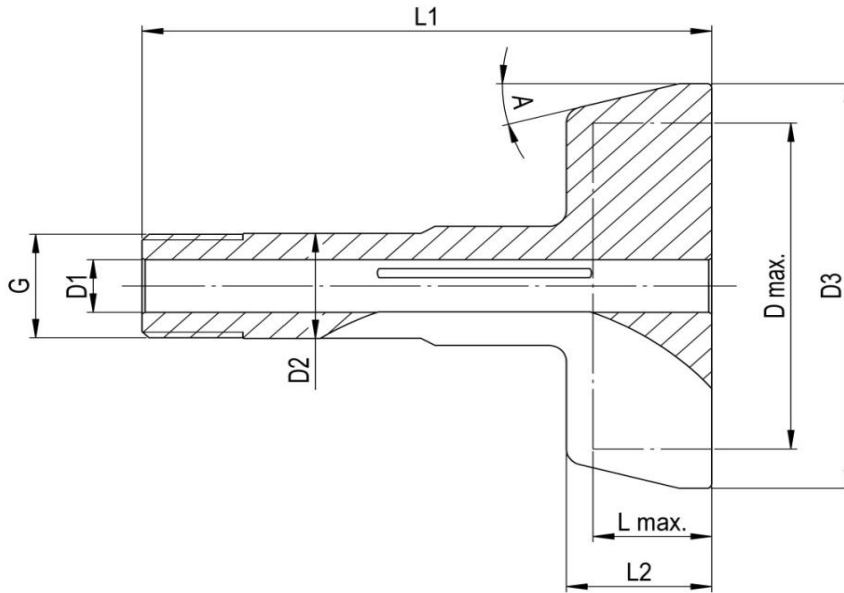

Abmessungen	D1	D2	D3	A	G
W20G02ZL	ø10	ø20	56	15°	ø19.7 x 1.667 - 45°/5°
W20G03ZL	ø10	ø20	77	15°	ø19.7 x 1.667 - 45°/5°

Fabry Bestell Nr:	Alte-Nr.	L1	L2	L max.	D max.	Bemerkungen
Standard						
W20G02ZL35SA4	82-52001	106.5	35	30	20	4-Schlitz
W20G02ZL40	82-52001	111.5	40	35	20	
W20G02ZL60	82-52001	131.5	60	55	20	
W20G02ZL80	82-52001	151.5	80	75	20	
W20G03ZL35	82-52002	106.5	35	30	20	
W20G03ZL40	82-52002	111.5	40	35	20	
W20G03ZL45	82-52002	116.5	45	40	20	
W20G03ZL50	82-52002	121.5	50	45	20	
W20G03ZL55	82-52002	126.5	55	50	20	
W20G03ZL60	82-52002	131.5	60	55	20	
W20G03ZL80	82-52002	151.5	80	75	20	

Für grössere Mengen und für andere Ausführungen kontaktieren Sie bitte unseren Verkauf
Tel: +41 61 935 93 00, verkauf@fabry.ch, www.fabry.ch

Spezifikation
Glockenzangen



FABRY AG
SPANNZANGEN-TECHNOLOGIE
CNC-Bearbeitung Drehen Fräsen Schleifen

Glockenspannzangen Typ W25G



Einheitsnummer -

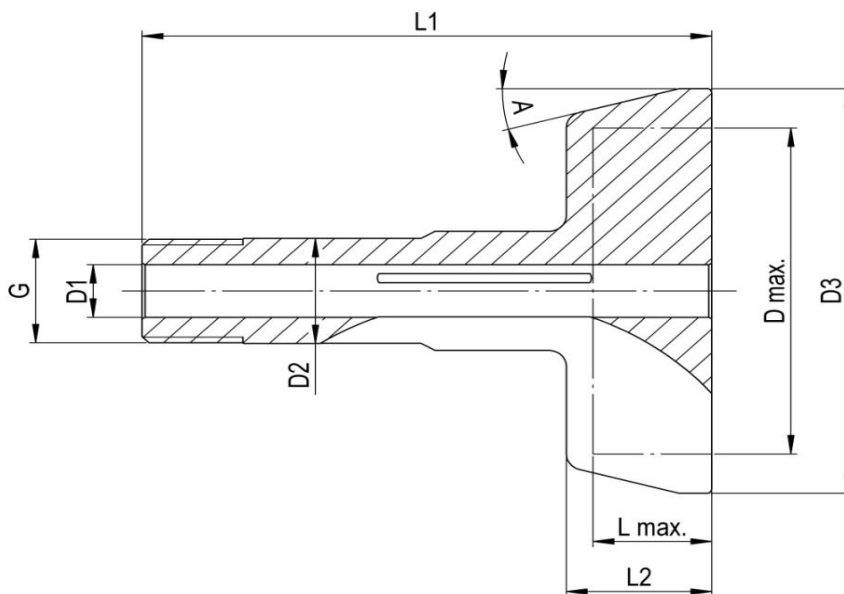

Abmessungen	D1	D2	D3	A	G
W25G01	∅10.5	∅25	56	15°	∅24.7 x 1.693 - 45°/5°
W25G02	∅10.5	∅25	88	15°	∅24.7 x 1.693 - 45°/5°
W25G03	∅10.5	∅25	120	15°	∅24.7 x 1.693 - 45°/5°
W25G04	∅10.5	∅25	150	15°	∅24.7 x 1.693 - 45°/5°
W25G05	∅10.5	∅25	182	15°	∅24.7 x 1.693 - 45°/5°

Fabry Bestell Nr:	Alte-Nr.	L1	L2	L max.	D max.	Bemerkungen
Standard						
W25G01	82-51011	120	24.5	20	∅40	
W25G01SA4	82-51011	120	24.5	20	∅40	4-Schlitz
W25G02	82-51012	120	24.5	20	∅72	
W25G02SA4	82-51012	120	24.5	20	∅72	4-Schlitz
W25G03	82-51013	120	24.5	20	∅104	
W25G04	82-51014	122.5	27	22	∅132	
W25G05	82-51015	122.5	27	22	∅165	

Für grössere Mengen und für andere Ausführungen kontaktieren Sie bitte unseren Verkauf
Tel: +41 61 935 93 00, verkauf@fabry.ch, www.fabry.ch

Spezifikation
Spreizdorne



Spreizdorne Typ W12



Einheitsnummer -

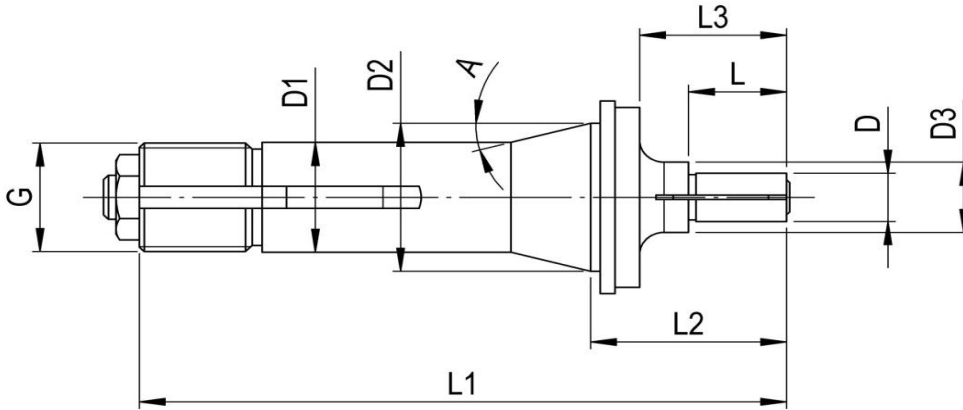

Abmessungen	D1	D2	A	G
W12SD..	ø12	ø16	15°	ø11.75 x 1.25 - 45°/5°

Fabry Bestell Nr:	Alte-Nr.	D	Stufung	D3	L	L1	L2	L3
W12SD..	84-50300	ø 04.00...05.00	0.5	8	10	67.5	24.1	18
		ø 05.50...06.00	0.5	8	10	67.5	24.1	18
		ø 06.50...08.00	0.5	10	10	67.5	24.1	18
		ø 08.50...10.00	0.5	12	15	69.5	26.1	20
		ø 10.50...12.00	0.5	15	15	69.5	26.1	20
		ø 12.50...15.00	0.5	-	20	72	28.6	-
		ø 15.50...18.00	0.5	-	25	77	33.6	-

Lieferbare Varianten		D	Stufung	D3	L	L1	L2	L3
W12SD..	84-50300	ø 04.00...19.99	0.01					

Für grössere Mengen und für andere Ausführungen kontaktieren Sie bitte unseren Verkauf
Tel: +41 61 935 93 00, verkauf@fabry.ch, www.fabry.ch

Spezifikation
Spreizdorne



FABRY AG
SPANNZANGEN-TECHNOLOGIE
CNC-Bearbeitung Drehen Fräsen Schleifen

Spreizdorne Typ W20



Einheitsnummer -

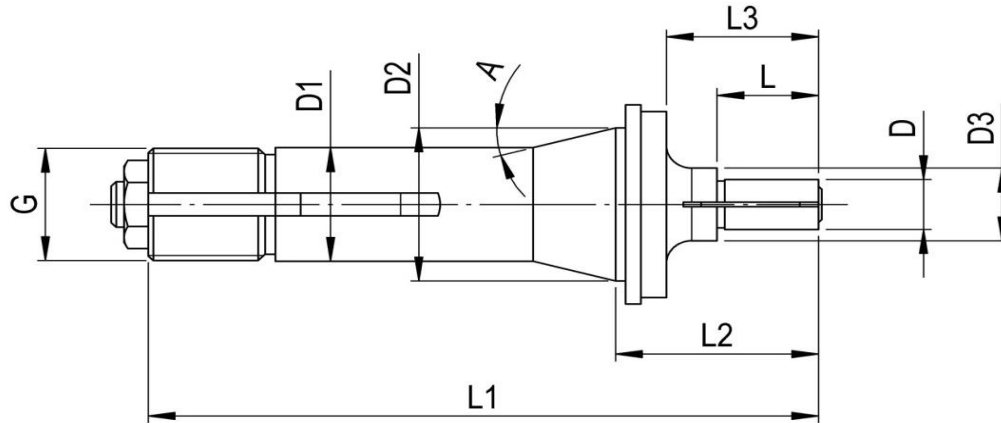

Abmessungen	D1	D2	A	G
W20SD..	ø20	ø26.3	15°	ø19.7 x 1.666 - 45°/5°

Fabry Bestell Nr:	Alte-Nr.	D	Stufung	D3	L	L1	L2	L3
W20SD..	84-51300	ø 04.00...05.00	0.5	10	12	103	32	24
		ø 05.50...06.00	0.5	10	15	104	33	25
		ø 06.50...08.00	0.5	12	15	104	33	25
		ø 08.50...10.00	0.5	14	15	104	33	25
		ø 10.50...13.00	0.5	16	20	109	38	30
		ø 13.50...17.00	0.5	20	25	114	43	35
		ø 17.50...21.00	0.5	24	25	114	43	35
		ø 21.50...25.00	0.5	28	35	124	53	45
		ø 25.50...31.00	0.5	-	45	124	53	-

Lieferbare Varianten	D		Stufung	D3	L	L1	L2	L3
W20SD..	84-51300	ø 04.00...31.00	0.01					

Für grössere Mengen und für andere Ausführungen kontaktieren Sie bitte unseren Verkauf
Tel: +41 61 935 93 00, verkauf@fabry.ch, www.fabry.ch



Einsätze

original Fabry



Einheitsnummer -

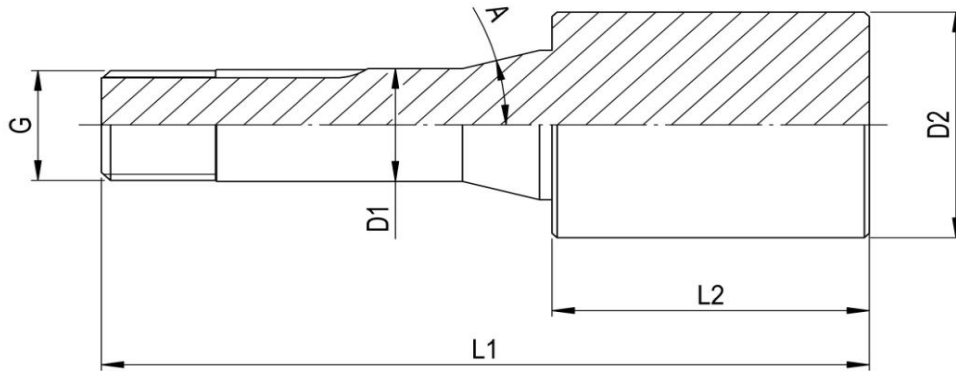

Abmessugen	D1	A	G
W10E	ø10	15°	ø9.83 x 0.833 - 45°/5°
W12E	ø12	15°	ø11.75 x 1.25 - 45°/5°
W15E	ø15	15°	ø14.75 x 1.25 - 45°/5°
W20E	ø20	15°	ø19.7 x 1.667 - 45°/5°
W25E	ø25	15°	ø24.7 x 1.693 - 45°/5°

Fabry Bestell Nr:	SV-Nr.	Bohrung Form	L1	L2	D2	Bemerkungen
W10E...ZL...	83-50001	ø 14.20 x 40.00				
		ø 14.20 x 80.00				
		ø 20.00 x 40.00				
		ø 25.00 x 40.00				
		ø 30.00 x 40.00				
		ø 40.00 x 40.00				
		ø 50.00 x 40.00				
W12E...ZL...	83-50003	ø 20.00 x 40.00				
		ø 20.00 x 100.00				
		ø 25.00 x 40.00				
		ø 25.00 x 100.00				
		ø 30.00 x 40.00				
		ø 30.00 x 100.00				
		ø 40.00 x 40.00				
		ø 40.00 x 100.00				
		ø 50.00 x 13.00				
		ø 50.00 x 40.00				
		ø 60.00 x 40.00				
W15E...ZL...	83-50005	ø 20.00 x 50.00				
		ø 20.00 x 100.00				
		ø 30.00 x 50.00				
		ø 30.00 x 100.00				

Tel: +41 61 935 93 00, verkauf@fabry.ch

W20E...ZL...	83-50007	∅ 30.00 x 50.00				
		∅ 30.00 x 100.00				
		∅ 30.00 x 150.00				
		∅ 30.00 x 200.00				
		∅ 30.00 x 300.00				
		∅ 35.00 x 50.00				
		∅ 35.00 x 100.00				
		∅ 35.00 x 150.00				
		∅ 35.00 x 200.00				
		∅ 40.00 x 50.00				
		∅ 40.00 x 100.00				
		∅ 40.00 x 150.00				
		∅ 40.00 x 200.00				
		∅ 40.00 x 300.00				
		∅ 50.00 x 50.00				
		∅ 50.00 x 100.00				
		∅ 60.00 x 50.00				
		∅ 60.00 x 100.00				
		∅ 60.00 x 120.00				
		∅ 60.00 x 150.00				
		∅ 70.00 x 100.00				
		∅ 80.00 x 50.00				
		∅ 80.00 x 100.00				
		∅ 100.00 x 30.00				
		∅ 100.00 x 40.00				
		∅ 100.00 x 50.00				
		∅ 100.00 x 70.00				
		∅ 100.00 x 100.00				
W25E...ZL...	83-50009	∅ 40.00 x 50.00				
		∅ 40.00 x 100.00				
		∅ 50.00 x 50.00				
		∅ 50.00 x 100.00				
		∅ 60.00 x 50.00				
		∅ 60.00 x 100.00				
		∅ 60.00 x 150.00				
		∅ 70.00 x 50.00				
		∅ 70.00 x 100.00				
		∅ 80.00 x 50.00				
		∅ 80.00 x 100.00				
		∅ 100.00 x 50.00				
		∅ 100.00 x 100.00				

Für grössere Mengen und für andere Ausführungen kontaktieren Sie bitte unseren Verkauf

Tel: +41 61 935 93 00, Fax: +41 61 935 93 05, verkauf@fabry.ch, www.fabry.ch

Spezifikation
Spreizdorne



FABRY AG
SPANNZANGEN-TECHNOLOGIE
CNC-Bearbeitung Drehen Fräsen Schleifen

Spreizdorne Typ W25



Einheitsnummer -

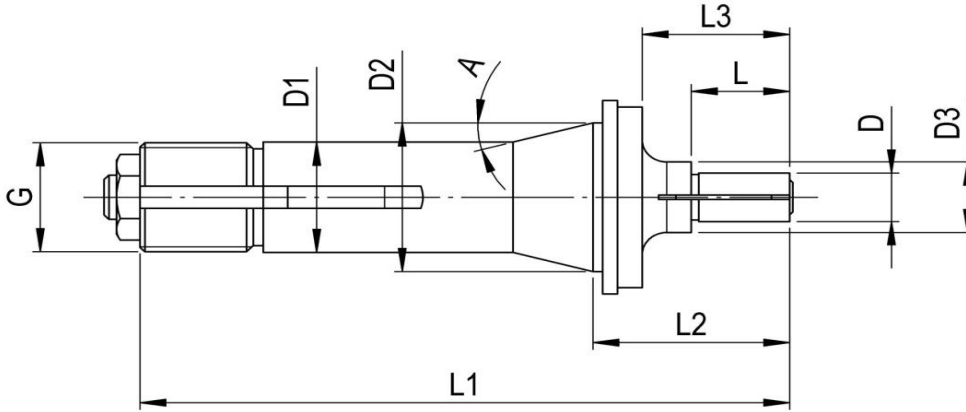

Abmessugen	D1	D2	A	G
W25SD..	ø25	ø33.7	15°	ø24.7x1.693 - 45°/5°

Fabry Bestell Nr:	Alte-Nr.	D	Stufung	D3	L	L1	L2	L3
W25SD..	84-52300	ø 04.00...05.00	0.5	10	12	126	34	24
		ø 05.50...06.00	0.5	122	15	127	35	25
		ø 06.50...08.00	0.5	16	15	127	35	25
		ø 08.50...10.00	0.5	16	15	127	35	25
		ø 10.50...13.00	0.5	16	20	132	40	30
		ø 13.50...17.00	0.5	20	25	137	45	35
		ø 17.50...21.00	0.5	24	30	142	50	40
		ø 21.50...25.00	0.5	28	35	147	55	45
		ø 25.50...29.00	0.5	32	40	152	60	50
		ø 29.50...33.00	0.5	36	45	152	60	50
		ø 33.50...39.00	0.5	-	50	153	61	-
		ø 39.50...41.00	0.5	-	50	153	61	-

Lieferbare Varianten		D						
W25SD..	84-52300	ø 04.00...41.00	0.01					

Für grössere Mengen und für andere Ausführungen kontaktieren Sie bitte unseren Verkauf
Tel: +41 61 935 93 00, verkauf@fabry.ch, www.fabry.ch

Einsätze W10 verdickt



Einheitsnummer -

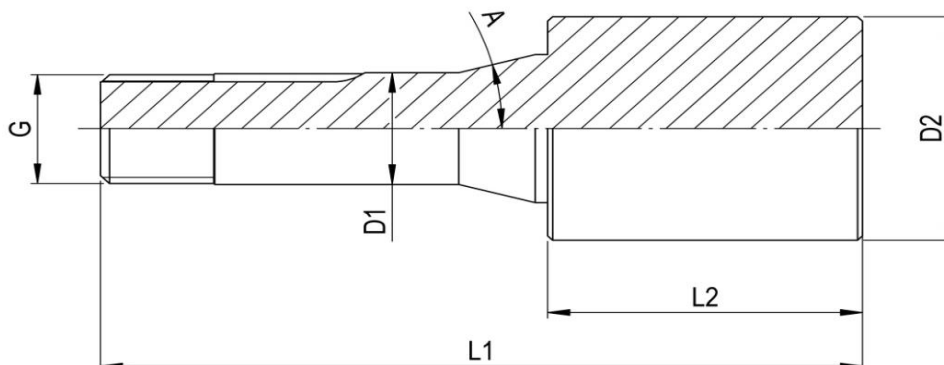

Abmessungen	D1	A	G
W10E	ø10	15°	ø9.83 x 0.833 - 45°/5°

Fabry Bestell Nr:	Alte-Nr.	Bohrung Form	L1	L2	D2	Bemerkungen
W10E...ZL...	83-50001	ø 14.20 x 40.00	82.5	40	14.2	
		ø 14.20 x 80.00	122.5	80	14.2	
		ø 20.00 x 40.00	82.5	40	20	
		ø 25.00 x 40.00	82.5	40	25	
		ø 30.00 x 40.00	82.5	40	30	
		ø 40.00 x 40.00	82.5	40	40	
		ø 50.00 x 40.00	82.5	40	50	

Für grössere Mengen und für andere Ausführungen kontaktieren Sie bitte unseren Verkauf
Tel: +41 61 935 93 00, verkauf@fabry.ch, www.fabry.ch



Einsätze W12 / W15 / W20 / W25



Einheitsnummer -

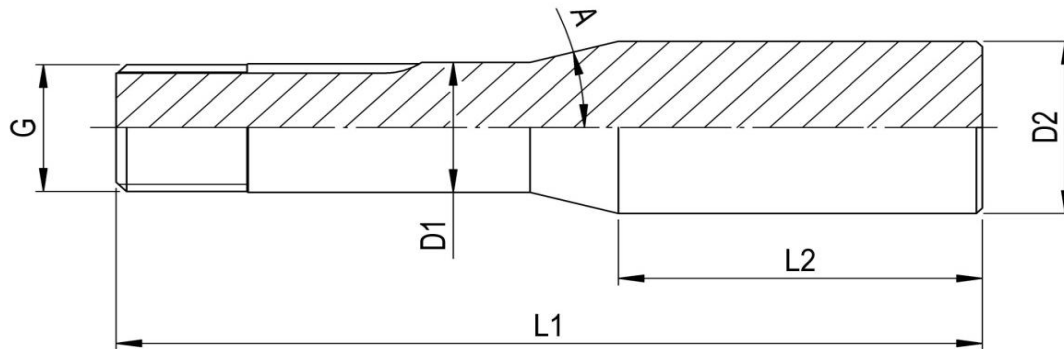

Abmessugen	D1	A	G
W12E	ø12	15°	ø11.75 x 1.25 - 45°/5°
W15E	ø15	15°	ø14.75 x 1.25 - 45°/5°
W20E	ø20	15°	ø19.7 x 1.667 - 45°/5°
W25E	ø25	15°	ø24.7 x 1.693 - 45°/5°

Fabry Bestell Nr:	Alte-Nr.	Bohrung Form	L1	L2	D2	Bemerkungen
W12E...ZL...	83-50002	ø 16.20 x 40.00	84.30	40.00	16.20	
		ø 16.20 x 100.00	144.3	100.00	16.20	
W15E...ZL...	83-50004	ø 20.00 x 50.00	106.3	50.00	20.00	
		ø 20.00 x 100.00	156.3	100.00	20.00	
W20E...ZL...	83-50006	ø 26.30 x 200.00	256.3	200.00	26.30	
		ø 26.50 x 100.00	170.6	100.00	26.50	
		ø 26.50 x 150.00	226.6	150.00	26.50	
		ø 26.50 x 20.00	91	20.00	26.50	
		ø 26.50 x 50.00	120.6	50.00	26.50	
W25E...ZL...	83-50008	ø 33.90 x 50.00	144.3	50.00	33.90	
		ø 33.90 x 100.00	194.3	100.00	33.90	
		ø 33.90 x 200.00	294.3	200.00	33.90	

Für grössere Mengen und für andere Ausführungen kontaktieren Sie bitte unseren Verkauf
Tel: +41 61 935 93 00, verkauf@fabry.ch, www.fabry.ch



Einsätze W12 verdickt



Einheitsnummer -

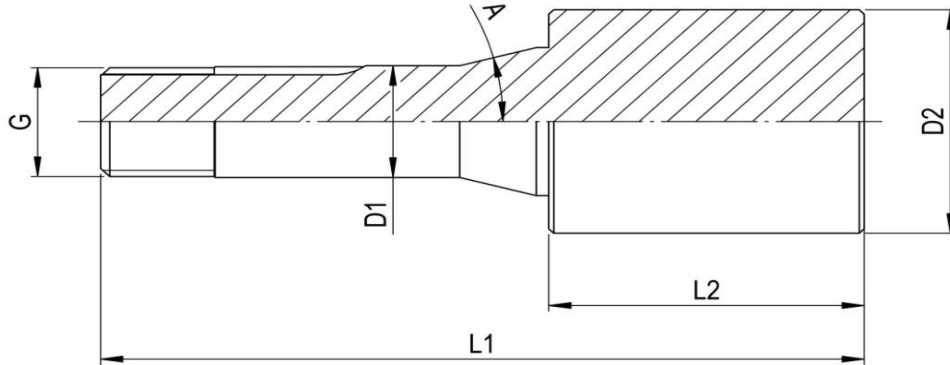

Abmessugen	D1	A	G
W12E	ø12	15°	ø11.75 x 1.25 - 45°/5°

Fabry Bestell Nr:	Alte-Nr.	Bohrung Form	L1	L2	D2	Bemerkungen
W12E...ZL...	83-50003	ø 20.00 x 40.00	84.30	40.00	20	
		ø 20.00 x 100.00	143.3	100	20	
		ø 25.00 x 40.00	84.30	40	25	
		ø 25.00 x 100.00	143.3	100	25	
		ø 30.00 x 40.00	84.30	40	30	
		ø 30.00 x 100.00	143.3	100	30	
		ø 40.00 x 40.00	84.30	40	40	
		ø 40.00 x 100.00	143.3	100	40	
		ø 50.00 x 13.00	56.3	13	50	
		ø 50.00 x 40.00	84.30	40	50	
		ø 60.00 x 40.00	84.30	40	60	
		ø 70.00 x 25.00	68.3	25	70	
		ø 75.00 x 25.00	68.3	25	75	

Für grössere Mengen und für andere Ausführungen kontaktieren Sie bitte unseren Verkauf
Tel: +41 61 935 93 00, verkauf@fabry.ch, www.fabry.ch



Einsätze W15 verdickt



Einheitsnummer -

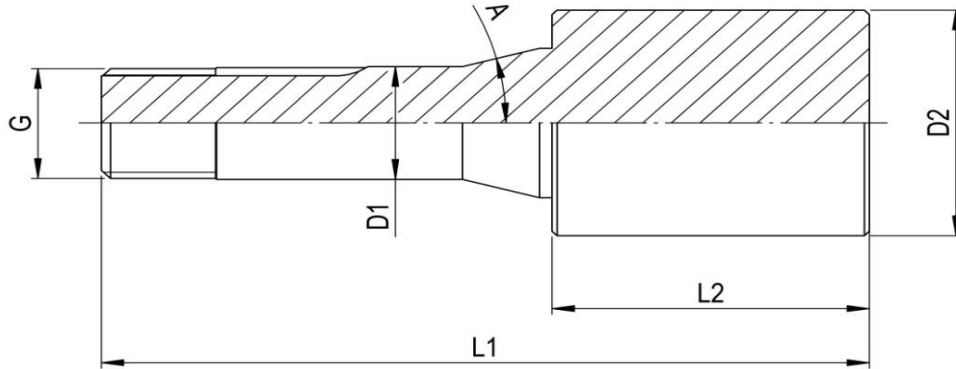

Abmessugen	D1	A	G
W15E	∅15	15°	∅14.75 x 1.25 - 45°/5°

Fabry Bestell Nr:	Alte-Nr.	Bohrung Form	L1	L2	D2	Bemerkungen
W15E...ZL...	83-50005	∅ 20.00 x 50.00	106.3	50	20	
		∅ 20.00 x 100.00	156.3	100	20	
		∅ 30.00 x 50.00	106.3	50	30	
		∅ 30.00 x 100.00	156.3	100	30	

Für grössere Mengen und für andere Ausführungen kontaktieren Sie bitte unseren Verkauf
Tel: +41 61 935 93 00, verkauf@fabry.ch, www.fabry.ch



Einsätze W20 verdickt



Einheitsnummer -

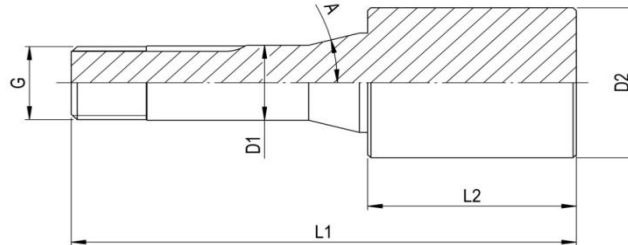

Abmessugen	D1	A	G
W20E	ø20	15°	ø19.7 x 1.667 - 45°/5°

Fabry Bestell Nr:	Alte-Nr.	Bohrung Form	L1	L2	D2	Bemerkungen
W20E...ZL...	83-50007	ø 30.00 x 50.00	120.6	50	30	
		ø 30.00 x 100.00	170.6	100	30	
		ø 30.00 x 150.00	220.6	150	30	
		ø 30.00 x 200.00	270.6	200	30	
		ø 30.00 x 300.00	370.6	300	30	
		ø 35.00 x 50.00	120.6	50	35	
		ø 35.00 x 100.00	170.6	100	35	
		ø 35.00 x 150.00	220.6	150	35	
		ø 35.00 x 200.00	270.6	200	35	
		ø 40.00 x 50.00	120.6	50	40	
		ø 40.00 x 100.00	170.6	100	40	
		ø 40.00 x 150.00	220.6	150	40	
		ø 40.00 x 200.00	270.6	200	40	
		ø 40.00 x 300.00	370.6	300	40	
		ø 50.00 x 50.00	120.6	50	50	
		ø 50.00 x 100.00	170.6	100	50	
		ø 60.00 x 50.00	120.6	50	60	
		ø 60.00 x 100.00	170.6	100	60	
		ø 60.00 x 120.00	190.6	120	60	
		ø 60.00 x 150.00	220.6	150	60	
		ø 70.00 x 100.00	170.6	100	70	
		ø 80.00 x 50.00	120.6	50	80	
		ø 80.00 x 100.00	170.6	100	80	
		ø 100.00 x 30.00	100.6	30	100	
		ø 100.00 x 40.00	110.6	40	100	
		ø 100.00 x 50.00	120.6	50	100	
		ø 100.00 x 70.00	140.6	70	100	
		ø 100.00 x 100.00	170.6	100	100	

Tel: +41 61 935 93 00, verkauf@fabry.ch, www.fabry.ch
Tel: +41 61 935 93 00, Fax: +41 61 935 93 05, verkauf@fabry.ch, www.fabry.ch



Einsätze W25 verdickt



Einheitsnummer -

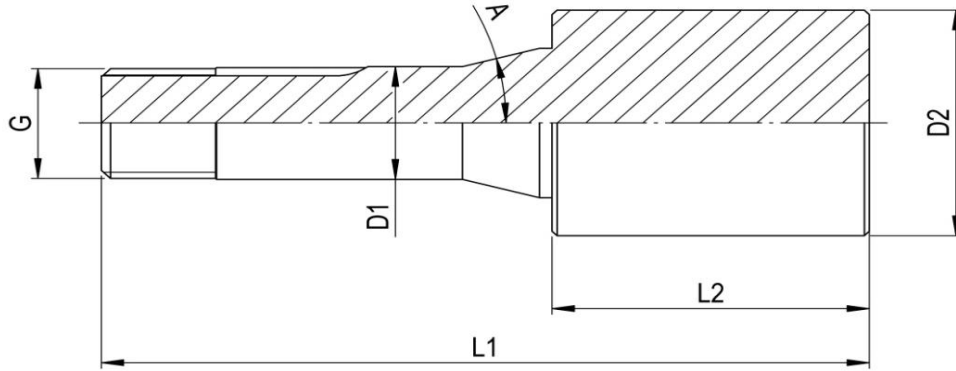

Abmessugen	D1	A	G
W25E	ø25	15°	ø24.7 x 1.693 - 45°/5°

Fabry Bestell Nr:	Alte-Nr.	Bohrung Form	L1	L2	D2	Bemerkungen
W25E...ZL...	83-50009	ø 40.00 x 50.00	144.3	50	40	
		ø 40.00 x 100.00	194.3	100	40	
		ø 50.00 x 50.00	144.3	50	50	
		ø 50.00 x 100.00	194.3	100	50	
		ø 60.00 x 50.00	144.3	50	60	
		ø 60.00 x 100.00	194.3	100	60	
		ø 60.00 x 150.00	244.3	150	60	
		ø 70.00 x 50.00	144.3	50	70	
		ø 70.00 x 100.00	194.3	100	70	
		ø 80.00 x 50.00	144.3	50	80	
		ø 80.00 x 100.00	194.3	100	80	
		ø 100.00 x 50.00	144.3	50	100	
		ø 100.00 x 100.00	194.3	100	100	

Für grössere Mengen und für andere Ausführungen kontaktieren Sie bitte unseren Verkauf
Tel: +41 61 935 93 00, verkauf@fabry.ch, www.fabry.ch



Einsätze B6 / B8 / B15 / B32



Einheitsnummer -

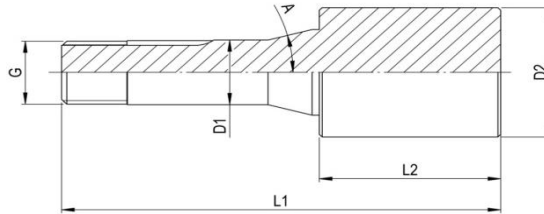

Abmessugen	D1	A	G
B6E	ø6	20°	ø 5.0x0.706 - 55°
B8E	ø8	20°	ø 6.82x0.625 - 55°
B15E	ø15	20°	M13x1
B32E	ø32	20°	ø 29.7x15f - 45°/5°

Fabry Bestell Nr:	Alte-Nr.	Bohrung Form	L1	L2	D2	Bemerkungen
B6E...ZL...	83-10003	ø 10.70 x 40.00	70.8	40	10.7	
		ø 15.00 x 40.00	70.8	40	15	
		ø 20.00 x 40.00	70.8	40	20	
		ø 30.00 x 40.00	70.8	40	30	
B8E...ZL...	83-10005	ø 13.20 x 40.00	73.8	40	13.2	
		ø 13.20 x 75.00	108.8	75	13.2	
		ø 13.20 x 100.00	133.8	100	13.2	
		ø 16.00 x 75.00	103.8	70	16	
		ø 16.00 x 100.00	133.8	100	16	
		ø 20.00 x 20.00	53.8	20	20	
		ø 20.00 x 40.00	73.8	40	20	
		ø 20.00 x 75.00	108.8	75	20	
		ø 20.00 x 100.00	133.8	100	20	
		ø 25.00 x 40.00	73.8	40	25	
		ø 30.00 x 40.00	73.8	40	30	
		ø 40.00 x 40.00	73.8	40	40	
B15E...ZL...	83-10007	ø 25.00 x 40.00	93.5	40	25	
		ø 30.00 x 40.00	93.5	40	30	
B32E...ZL...	83-10001	ø 50.00 x 50.00	152	50	50	
		ø 50.00 x 100.00	202	100	50	
		ø 60.00 x 50.00	152	50	60	
		ø 60.00 x 100.00	202	100	60	
		ø 80.00 x 50.00	152	50	80	
		ø 80.00 x 100.00	202	100	80	
		ø 100.00 x 50.00	152	50	100	
		ø 100.00 x 100.00	202	100	100	

Tel: +41 61 935 93 00, verkauf@fabry.ch, www.fabry.ch
 Tel: +41 61 935 93 00, Fax: +41 61 935 93 05, verkauf@fabry.ch, www.fabry.ch

Spezifikation
Spannzangen



FABRY AG

SPANNZANGEN-TECHNOLOGIE
CNC-Bearbeitung Drehen Fräsen Schleifen

Einsätze P6 / P10 / P16



Einheitsnummer -

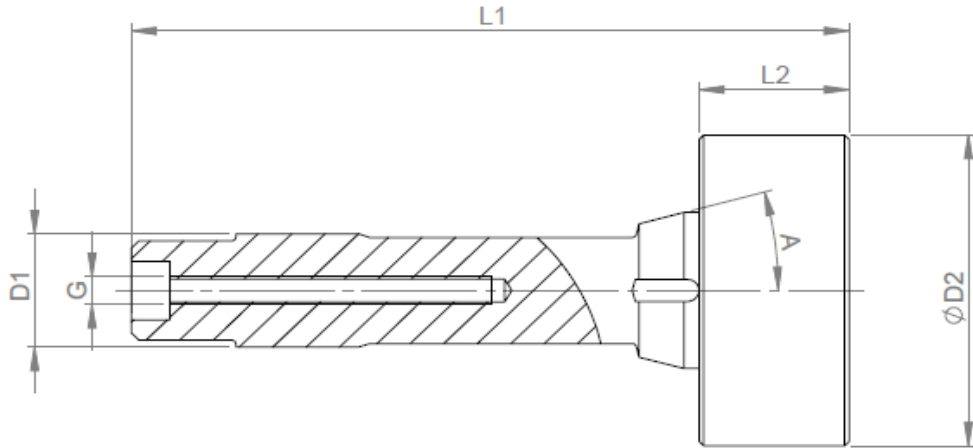

Abmessugen	D1	A	G
P6E	ø6	15°	M4
P10E	ø10	15°	M7
P16E	ø16	15°	M8

Fabry Bestell Nr:	Alte-Nr.	Bohrung Form	L1	L2	D2	Bemerkungen	
P6E...ZL...	83-40003	ø 12.00 x 25.00	52	25	12		
		ø 15.00 x 25.00	52	25	15		
		ø 25.00 x 25.00	52	25	25		
P10E...ZL...	83-40001	ø 14.20 x 20.00	58	20	14.2		
		ø 14.20 x 40.00	78	40	14.2		
		ø 20.00 x 20.00	58	20	20		
		ø 20.00 x 40.00	78	40	20		
		ø 25.00 x 20.00	58	20	25		
		ø 25.00 x 40.00	78	40	25		
		ø 30.00 x 20.00	58	20	30		
P16E...ZL...	83-40006	ø 40.00 x 20.00	96	20	40		
		ø 50.00 x 20.00	96	20	50		

Für grössere Mengen und für andere Ausführungen kontaktieren Sie bitte unseren Verkauf
Tel: +41 61 935 93 00, verkauf@fabry.ch, www.fabry.ch