



FABRY AG

SPANNZANGEN-TECHNOLOGIE

CNC-Bearbeitung Drehen Fräsen Schleifen

INHALTSVERZEICHNIS

- 1 DRUCKSPANNZANGEN
- 2 ZUGSPANNZANGEN
- 3 HYDROMATSPANNZANGEN
- 4 INDEXSPANNZANGEN
- 5 GLOCKENZANGEN, SPREIZDORNE, EINSÄTZE
- 6 SCHNELLSPANNFUTTER / SPANNZANGENAUFNAHMEN
- 7 SPANNZANGENANSCHLÄGE
- 8 FÜHRUNGSBÜCHSEN / HM-CANON
- 9 ZANGEN FÜR STANGENLADER, VORSCHUBZANGEN
- 10 WERKZEUGSPANNUNG REGO-FIX / SCHAUBLIN
- 11 ZUBEHÖR / SPEZIALPRODUKTE
- 12 PREISLISTEN

**Spezifikation
Spannzangen**



FABRY AG

SPANNZANGEN-TECHNOLOGIE
CNC-Bearbeitung Drehen Fräsen Schleifen

Spannzangen Typ F4.5



Einheitsnummer -

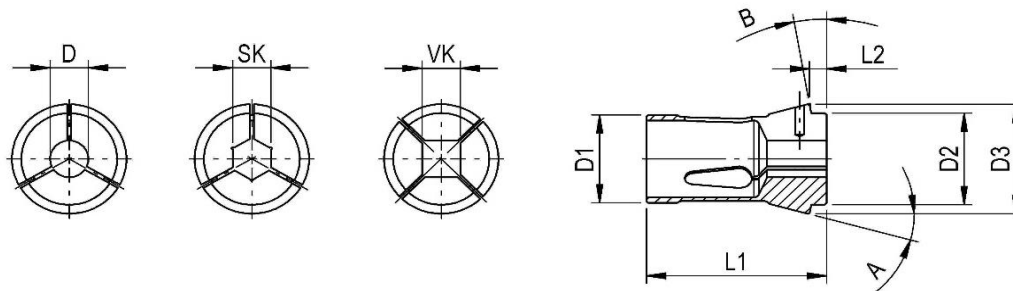

Spezifikation	D1	D2	D3	L1	L2	A	B	
F4.5	4.5	4.5	6.75	17.25	1.8	15°	0°	

Fabry Bestell Nr:	Alte-Nr.	Bohrung Form	Bohrung	Stufung	Bemerkungen
Standard		Rund D			
F4.5D00.30...01.50G	76-00076	ø0.30 - ø1.50	Glatt	0.10 mm	
F4.5D02.00...03.50G	76-00076	ø2.00 - ø3.50	Glatt	0.50 mm	
Lieferbare Varianten		Rund D			
F4.5D00.30...04.50G	76-00076	ø0.30 - ø4.50	Glatt	0.01 mm	

Für grössere Mengen und für andere Ausführungen kontaktieren Sie bitte unseren Verkauf

Tel: +41 61 935 93 00, verkauf@fabry.ch, www.fabry.ch

**Spezifikation
Spannzangen**



FABRY AG

SPANNZANGEN-TECHNOLOGIE
CNC-Bearbeitung Drehen Fräsen Schleifen

Spannzangen Typ F6



Einheitsnummer 100E

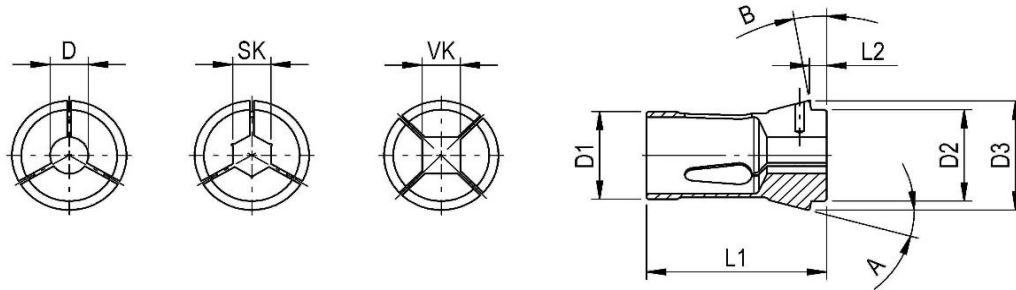

Spezifikation	D1	D2	D3	L1	L2	A	B	
F6	6	6	10	30	3	15°	0°	

Fabry Bestell Nr:	Alte-Nr.	Bohrung Form	Bohrung	Stufung	Bemerkungen
Standard		Rund D			
F6D00.50...04.00G	76-00599	ø0.50 - ø4.00	Glatt	0.50 mm	
Lieferbare Varianten		Rund D			
F6D00.50...04.50G	76-00599	ø0.50 - ø4.50	Glatt	0.01 mm	

Für grössere Mengen und für andere Ausführungen kontaktieren Sie bitte unseren Verkauf

Tel: +41 61 935 93 00, verkauf@fabry.ch, www.fabry.ch



Restposten Spannzangen Typ F7- F10



Einheitsnummer -

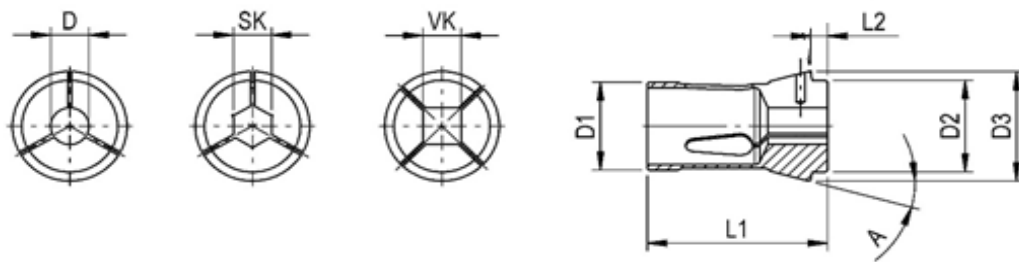

Spezifikation	D1	D2	D3	L1	L2	A		
F7(76-00576)	7	7	11	41	5	16°		
F8(76-00719)	8	8	14	35	3	15°		
F8(76-01079)	8	8	12	41	3.5	16°		
F8(76-01181)	8	8	11.2	19.5	2.3	15°		
F9(76-00077)	9	9	13.3	36.5	3	20°		
F10(76-01080)	10	10	16	46.5	5	20°		

Fabry Bestell Nr:	Alte-Nr.	Bohrung	Form	Stufung	Bemerkungen
F7(76-00576)	76-00576	ø00.50 - ø05.00	Rund	0.50 mm	Restposten
F8(76-00719)	76-00719	ø01.00 - ø05.50	Rund	0.50 mm	Restposten
F8(76-01079)	76-01079	ø01.00 - ø06.00	Rund	0.50 mm	Restposten
F8(76-01181)	76-01181	ø01.30 - ø06.50	Rund	0.50 mm	Restposten
F9(76-00077)	76-00077	ø00.50 - ø07.00	Rund	0.50 mm	Restposten
F10(76-01080)	76-01080	ø00.40 - ø08.00	Rund	0.50 mm	Restposten

Für grössere Mengen und für andere Ausführungen kontaktieren Sie bitte unseren Verkauf

Tel: +41 61 935 93 00, verkauf@fabry.ch, www.fabry.ch

Spezifikation
Spannzangen



FABRY AG

SPANNZANGEN-TECHNOLOGIE
CNC-Bearbeitung Drehen Fräsen Schleifen

Spannzangen Typ F7K10.5

FAB

Einheitsnummer -

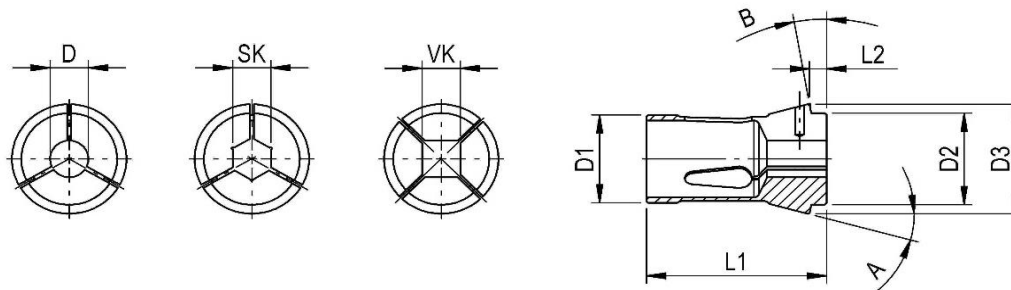

Spezifikation	D1	D2	D3	L1	L2	A	B
F7K10.5	7	7	10.5	26	3	15°	0°

Fabry Bestell Nr:	Alte-Nr.	Bohrung Form	Bohrung	Stufung	Bemerkungen
Standard		Rund D			
F7K10.5D00.50...05.50G	76-00206	ø0.50 - ø5.50	Glatt	0.10 mm	
Lieferbare Varianten		Rund D			
F7K10.5D00.50...05.50G	76-00206	ø0.50 - ø5.50	Glatt	0.01 mm	

Für grössere Mengen und für andere Ausführungen kontaktieren Sie bitte unseren Verkauf

Tel: +41 61 935 93 00, verkauf@fabry.ch, www.fabry.ch

**Spezifikation
Spannzangen**



FABRY AG

SPANNZANGEN-TECHNOLOGIE
CNC-Bearbeitung Drehen Fräsen Schleifen

Spannzangen Typ F7K10.7



Einheitsnummer 1020 E

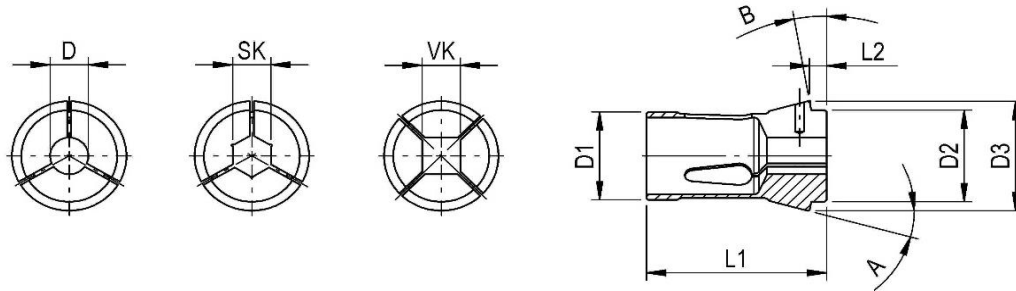

Spezifikation	D1	D2	D3	L1	L2	A	B	
F7K10.7	7	7	10.7	26	2.9	15°	6°	
Fabry Bestell Nr:	Alte-Nr.	Bohrung Form	Bohrung	Stufung	Bemerkungen			
Standard		Rund D						
F7K10.7D00.50...01.50G	76-00066	ø0.50 - ø1.50	Glatt	0.10 mm				
F7K10.7D02.00...05.00G	76-00066	ø2.00 - ø5.00	Glatt	0.50 mm				
Lieferbare Varianten		Rund D						
F7K10.7D00.50...05.50G	76-00066	ø0.50 - ø5.50	Glatt	0.01 mm				

Für grössere Mengen und für andere Ausführungen kontaktieren Sie bitte unseren Verkauf

Tel: +41 61 935 93 00, verkauf@fabry.ch, www.fabry.ch

**Spezifikation
Spannzangen**



FABRY AG

SPANNZANGEN-TECHNOLOGIE
CNC-Bearbeitung Drehen Fräsen Schleifen

Spannzangen Typ F8A15



Einheitsnummer -

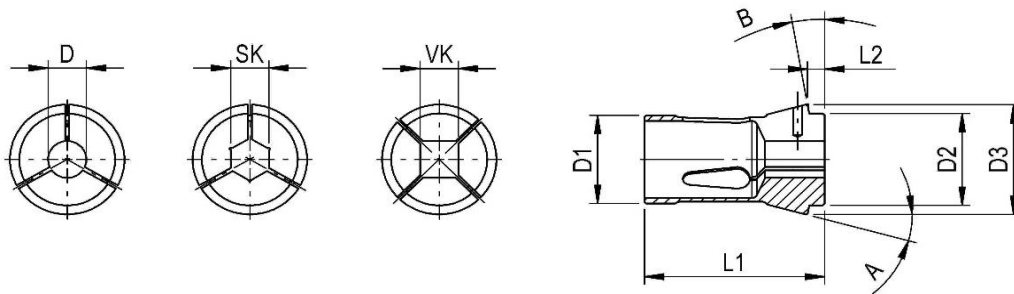

Spezifikation	D1	D2	D3	L1	L2	A	B	
F8A15	8	8	11	19	2	15°	0°	

Fabry Bestell Nr:	Alte-Nr.	Bohrung Form	Bohrung	Stufung	Bemerkungen
Standard		Rund D			
F8A15D01.00...03.50G	76-01844	ø1.00 - ø3.50	Glatt	0.50 mm	
F8A15D04.00...06.00G	76-01844	ø4.00 - ø6.00	Glatt	1.00 mm	
Lieferbare Varianten		Rund D			
F8A15D01.00...06.00G	76-01844	ø1.00 - ø6.00	Glatt	0.01 mm	

Für grössere Mengen und für andere Ausführungen kontaktieren Sie bitte unseren Verkauf

Tel: +41 61 935 93 00, verkauf@fabry.ch, www.fabry.ch



Restposten Spannzangen Typ F15 - F24



Einheitsnummer -

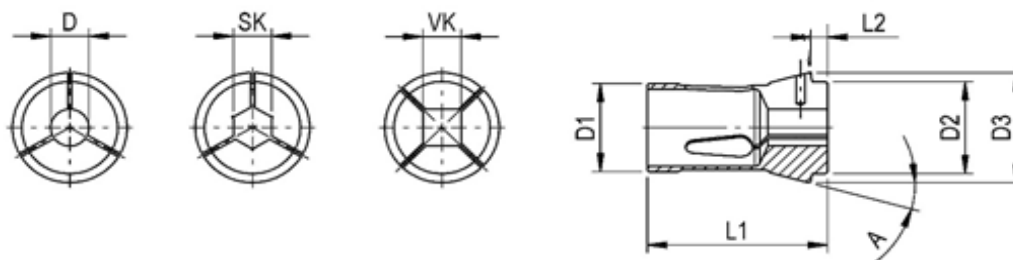

Spezifikation	D1	D2	D3	L1	L2	A		
F15(76-01902)	15	15	19.2	24	2	15°		
F17.46(76-00079)	17.46	16	22.05	51	5	15°		
F18(76-00085)	18	19.5	25	67	7	15°		
F20(76-01251)	20	20	25.2	28	2.5	15°		
F22(76-00088)	22	23.5	28	67	7	13°		
F22(76-00727)	22	25	32	66	7	16°		
F23.8(76-01214)	23.8	20.6	28.57	63.5	6.35	15°15'		

Fabry Bestell Nr:	Alte-Nr.	Bohrung	Form	Stufung	Bemerkungen
F15(76-01902)	76-01902	ø01.00 - ø13.49	Rund	0.50 mm	Restposten
F17.46(76-00079)	76-00079	ø02.00 - ø13.00	Rund	0.50 mm	Restposten
F18(76-00085)	76-00085	ø03.50 - ø13.00	Rund	0.50 mm	Restposten
F18SK(76-00085)	76-00085	SK05.50 - SK11.00	6-Kant	0.50 mm	Restposten
F20(76-01251)	76-01251	ø02.00 - ø16.00	Rund	0.50 mm	Restposten
F22(76-00088)	76-00088	ø02.00 - ø17.00	Rund	0.50 mm	Restposten
F22SK(76-00088)	76-00088	SK06.00 - SK16.00	6-Kant	1.0 mm	Restposten
F22(76-00727)	76-00727	ø03.00 - ø18.00	Rund	0.50 mm	Restposten
F22VK(76-00727)	76-00727	VK04.00 - VK12.00	4-Kant	1.0 mm	Restposten
F22SK(76-00727)	76-00727	SK05.00 - SK12.00	6-Kant	1.0 mm	Restposten
F23.8(76-01214)	76-01214	ø12.00 - ø16.00	Rund	0.50 mm	Restposten

Für grössere Mengen und für andere Ausführungen kontaktieren Sie bitte unseren Verkauf

Tel: +41 61 935 93 00, verkauf@fabry.ch, www.fabry.ch

**Spezifikation
Spannzangen**



FABRY AG
 SPANNZANGEN-TECHNOLOGIE
 CNC-Bearbeitung Drehen Fräsen Schleifen

Spannzangen Typ F8A16



Einheitsnummer 101 E

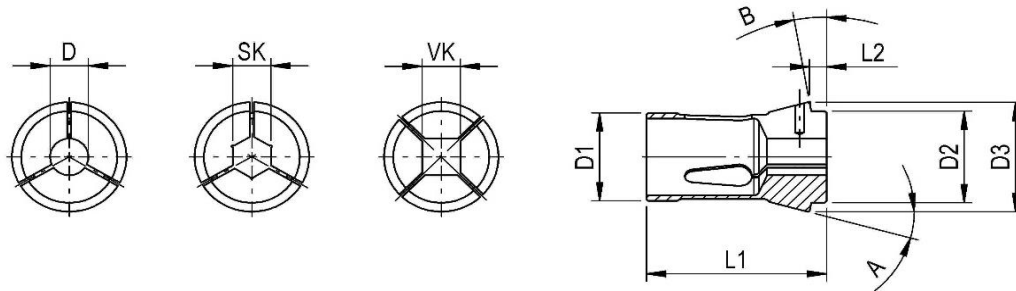

Spezifikation	D1	D2	D3	L1	L2	A	B	
F8A16	8	8	12	42	4.5	16°	0°	

Fabry Bestell Nr:	Alte-Nr.	Bohrung Form	Bohrung	Stufung	Bemerkungen
Standard		Rund D			
F8A16D00.20...00.90G	76-00577	ø0.30 - ø0.90	Glatt	0.05 mm	
F8A16D01.00...04.00G	76-00577	ø1.00 - ø4.00	Glatt	0.10 mm	
F8A16D04.50...06.35G	76-00577	ø4.50 - ø6.35	Glatt	0.50 mm	
Lieferbare Varianten		Rund D			
F8A16D0.20...06.35G	76-00577	ø0.20 - ø6.35	Glatt	0.01 mm	

Für grössere Mengen und für andere Ausführungen kontaktieren Sie bitte unseren Verkauf

Tel: +41 61 935 93 00, verkauf@fabry.ch, www.fabry.ch

**Spezifikation
Spannzangen**



FABRY AG
 SPANNZANGEN-TECHNOLOGIE
 CNC-Bearbeitung Drehen Fräsen Schleifen

Spannzangen Typ F10K15.5



Einheitsnummer 109 E

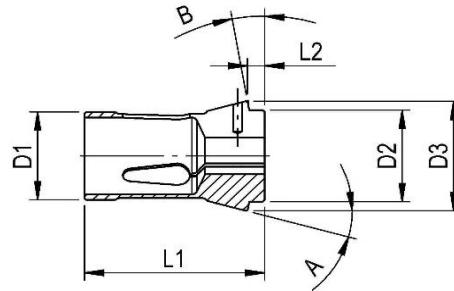
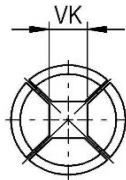
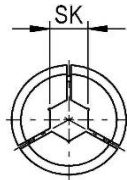
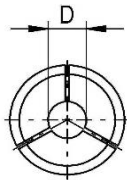

Spezifikation	D1	D2	D3	L1	L2	A	B	
F10K15.5	10	10	15.5	47.5	5.5	20°	0°	

Fabry Bestell Nr:	Alte-Nr.	Bohrung Form	Bohrung	Stufung	Bemerkungen
Standard		Rund D			
F10K15.5D00.30...04.00G	76-00086	ø0.30 - ø4.00	Glatt	0.10 mm	
F10K15.5D04.50...07.00G	76-00086	ø4.50 - ø7.00	Glatt	0.50 mm	
Lieferbare Varianten		Rund D			
F10K15.5D00.30...07.00G	76-00086	ø0.30 - ø7.00	Glatt	0.01 mm	

Für grössere Mengen und für andere Ausführungen kontaktieren Sie bitte unseren Verkauf

Tel: +41 61 935 93 00, verkauf@fabry.ch, www.fabry.ch

**Spezifikation
Spannzangen**



FABRY AG

SPANNZANGEN-TECHNOLOGIE
CNC-Bearbeitung Drehen Fräsen Schleifen

Spannzangen Typ F10K16



Einheitsnummer 111 E

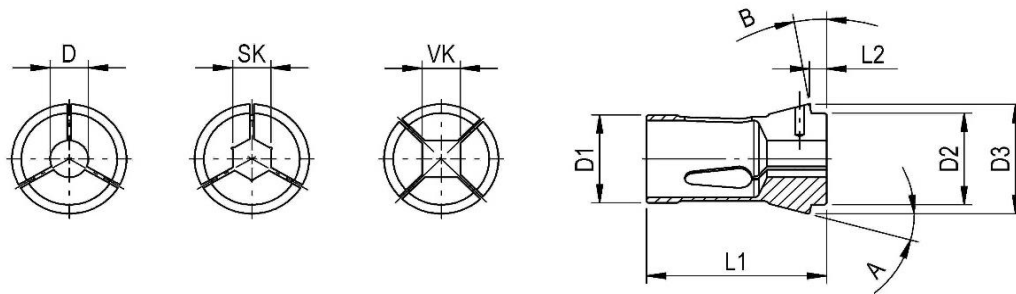

Spezifikation	D1	D2	D3	L1	L2	A	B	
F10K16	10	10	16	46	4	20°	12°	

Fabry Bestell Nr:	Alte-Nr.	Bohrung Form	Bohrung	Stufung	Bemerkungen
Standard		Rund D			
F10K16D00.50...07.00G	76-01178	ø0.50 - ø7.00	Glatt	0.50 mm	
Lieferbare Varianten		Rund D			
F10K16D00.50...07.00G	76-01178	ø0.50 - ø7.00	Glatt	0.01 mm	

Für grössere Mengen und für andere Ausführungen kontaktieren Sie bitte unseren Verkauf

Tel: +41 61 935 93 00, verkauf@fabry.ch, www.fabry.ch



Schnabelspannzangen Typ F10



Einheitsnummer -

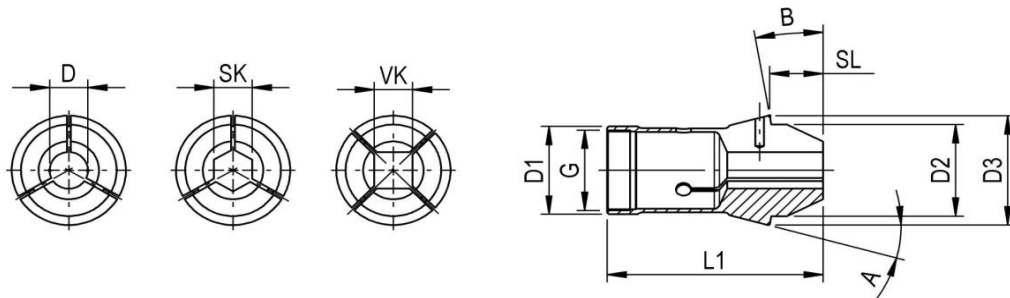

Spezifikation	D1	D2	D3	L1	SL	A	B	G
F10SL10...M8X0.5	10	10	15.5	52	10	20°	0°	M8x0.5

Fabry Bestell Nr:	Alte-Nr.	Bohrung Form	Bohrung	Stufung	Bemerkungen
Lieferbare Varianten		Rund D			
F10SL10D00.80...07.00GM8X0.5	76-02021	∅0.80 - ∅7.00	Glatt	0.01 mm	Schnabellänge 10 mm

Für grössere Mengen und für andere Ausführungen kontaktieren Sie bitte unseren Verkauf

Tel: +41 61 935 93 00, verkauf@fabry.ch, www.fabry.ch

**Spezifikation
Spannzangen**



FABRY AG

SPANNZANGEN-TECHNOLOGIE
CNC-Bearbeitung Drehen Fräsen Schleifen

Spannzangen Typ F12A15



Einheitsnummer 1155 E

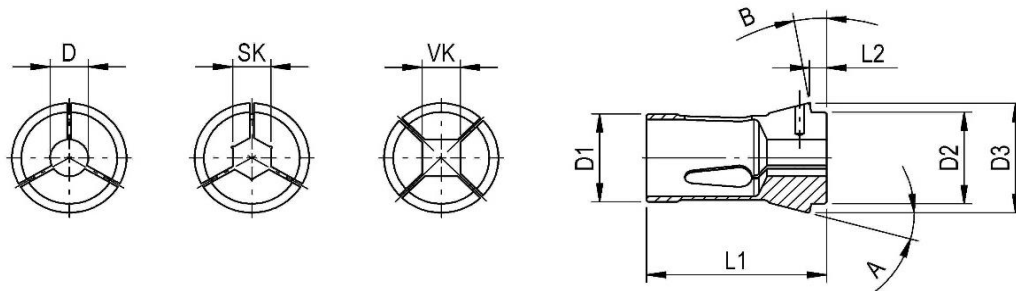

Spezifikation	D1	D2	D3	L1	L2	A	B
F12A15	12	12	18.1	44.5	4.3	15°	5°

Fabry Bestell Nr:	Alte-Nr.	Bohrung Form	Bohrung	Stufung	Bemerkungen
Standard		Rund D			
F12A15D00.50...02.50G	76-00078	ø0.50 - ø2.50	Glatt	0.10 mm	
F12A15D03.00...10.00G	76-00078	ø3.00 - ø10.00	Glatt	0.50 mm	
Lieferbare Varianten		Rund D			
F12A15D00.40...10.00G	76-00078	ø0.40 - ø10.00	Glatt	0.01 mm	

Für grössere Mengen und für andere Ausführungen kontaktieren Sie bitte unseren Verkauf

Tel: +41 61 935 93 00, verkauf@fabry.ch, www.fabry.ch

**Spezifikation
Spannzangen**



FABRY AG

SPANNZANGEN-TECHNOLOGIE
CNC-Bearbeitung Drehen Fräsen Schleifen

Spannzangen Typ F12A16



Einheitsnummer 114 E

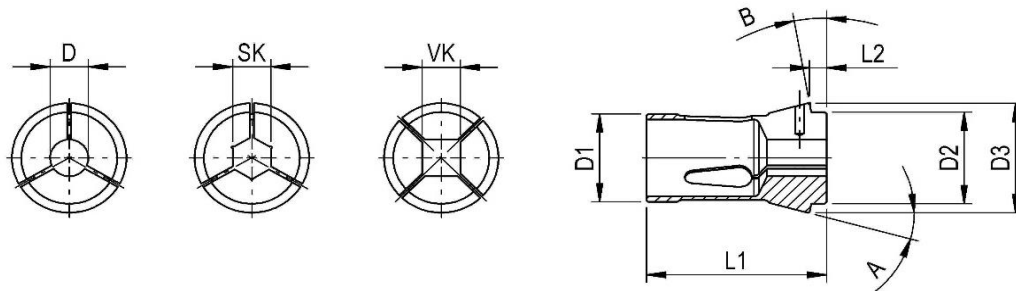

Spezifikation	D1	D2	D3	L1	L2	A	B	
F12A16	12	12	18	64	6	16°	0°	

Fabry Bestell Nr:	Alte-Nr.	Bohrung Form	Bohrung	Stufung	Bemerkungen
Standard		Rund D			
F12A16D01.00...10.00G	76-00578	ø1.00 - ø10.00	Glatt	0.50 mm	
Lieferbare Varianten		Rund D			
F12A16D01.00...10.00G	76-00578	ø1.00 - ø10.00	Glatt	0.01 mm	

Für grössere Mengen und für andere Ausführungen kontaktieren Sie bitte unseren Verkauf

Tel: +41 61 935 93 00, verkauf@fabry.ch, www.fabry.ch



Spannzangen Typ F13



Einheitsnummer 116 E

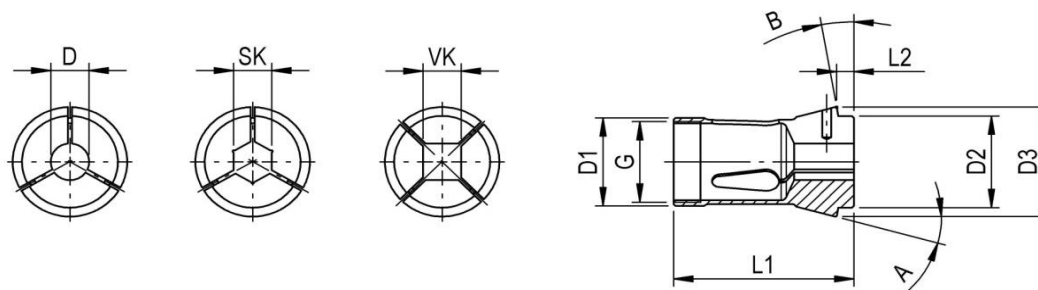

Spezifikation	D1	D2	D3	L1	L2	A	B	G
F13	13	13	19	64	6	16°	0°	
F13ZL8...M11X0.75	13	13	19	66	8	16°	0°	M11x0.75
F13NZL12	13	13	19	70	12	16°	0°	

Fabry Bestell Nr:	Alte-Nr.	Bohrung Form	Bohrung	Stufung	Bemerkungen
Standard		Rund D			
F13D00.50...08.50G	76-00357	ø0.50 - ø8.50	Glatt	0.50 mm	
F13D09.00...10.00R	76-00357	ø9.00 - ø10.00	Rillen	0.50 mm	
Lieferbare Varianten		Rund D			
F13D00.50...10.10G	76-00357	ø0.50 - ø10.10	Glatt	0.01 mm	
F13D09.00...10.50R	76-00357	ø9.00 - ø10.50	Rillen	0.01 mm	
F13ZL8D03.00...08.00GM11X0.75	76-93019	ø3.00 - ø8.00	Glatt	0.01 mm	Zylindrisch verlängert
Standard		Sechskant SK			
F13SK04.00...08.00G	76-00357	4.00 - 8.00	Glatt	1.0 mm	
Lieferbare Varianten		Sechskant SK			
F13SK02.00...08.00G	76-00357	2.00 - 8.00	Glatt	0.01 mm	
Standard		Vierkant VK			
F13VK04.00...07.00G	76-00357	4.00 - 7.00	Glatt	1.0 mm	
Lieferbare Varianten		Vierkant VK			
F13VK03.00...07.00G	76-00357	3.00 - 7.00	Glatt	0.01 mm	
Notfall					
F13NZL12D02.00V	76-53002	Vorbohrung ø2.0mm			Notfallzange Kopf weich

Für grössere Mengen und für andere Ausführungen kontaktieren Sie bitte unseren Verkauf

Tel: +41 61 935 93 00, verkauf@fabry.ch, www.fabry.ch



Schnabelspannzangen Typ F13



Einheitsnummer -

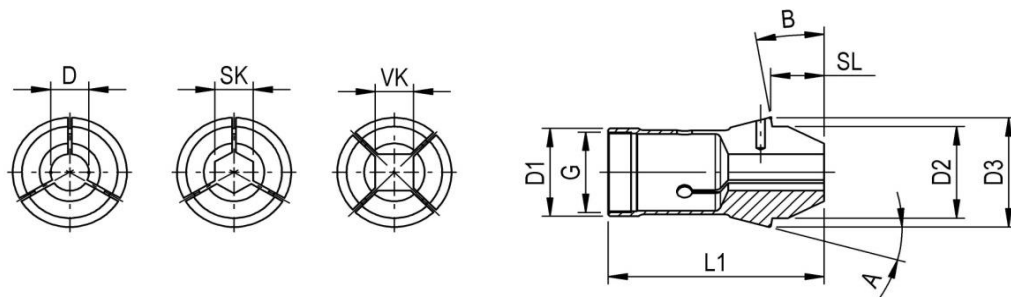

Spezifikation	D1	D2	D3	L1	SL	A	B	G
F13SL12...M11X0.75	13	13	19	70	12	16°	0°	M11x0.75

Fabry Bestell Nr:	Alte-Nr.	Bohrung Form	Bohrung	Stufung	Bemerkungen
Lieferbare Varianten		Rund D			
F13SL12D00.50...08.00GM11X0.75	76-02014	∅0.50 - ∅8.00	Glatt	0.01 mm	Schnabellänge 12 mm

Für grössere Mengen und für andere Ausführungen kontaktieren Sie bitte unseren Verkauf

Tel: +41 61 935 93 00, verkauf@fabry.ch, www.fabry.ch

Spezifikation
Spannzangen



FABRY AG

SPANNZANGEN-TECHNOLOGIE
CNC-Bearbeitung Drehen Fräsen Schleifen

Spannzangen Typ F14



Einheitsnummer 117 E

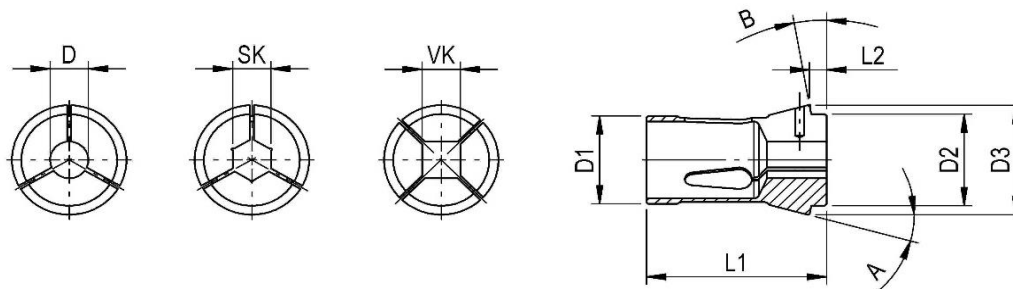

Spezifikation	D1	D2	D3	L1	L2	A	B	
F14	14	14	18	46	4	13°	12°	

Fabry Bestell Nr:	Alte-Nr.	Bohrung Form	Bohrung	Stufung	Bemerkungen
Standard		Rund D			
F14D01.00...08.50G	76-00098	ø1.00 - ø8.50	Glatt	0.50 mm	
F14D09.00...10.00R	76-00098	ø9.00 - ø10.00	Rillen	0.50 mm	
Lieferbare Varianten		Rund D			
F14D00.50...10.30G	76-00098	ø0.50 - ø10.30	Glatt	0.01 mm	
F14D09.00...11.00R	76-00098	ø9.00 - ø11.00	Rillen	0.01 mm	
Lieferbare Varianten		Sechskant SK			
F14SK02.00...10.00G	76-00098	2.00 - 10.00	Glatt	0.01 mm	
Lieferbare Varianten		Vierkant VK			
F14VK04.00...08.00G	76-00098	4.00 - 8.00	Glatt	0.01 mm	

Für grössere Mengen und für andere Ausführungen kontaktieren Sie bitte unseren Verkauf

Tel: +41 61 935 93 00, verkauf@fabry.ch, www.fabry.ch

Spezifikation
Spannzangen



FABRY AG

SPANNZANGEN-TECHNOLOGIE
CNC-Bearbeitung Drehen Fräsen Schleifen

Spannzangen Typ F15A16



Einheitsnummer 120 E

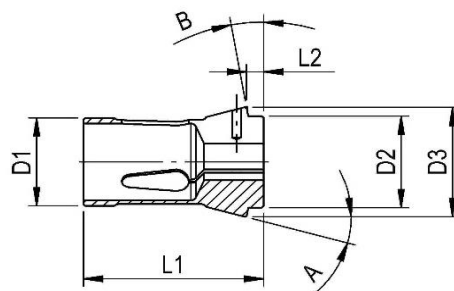
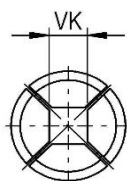
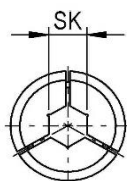
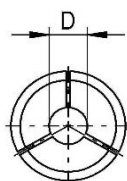

Spezifikation	D1	D2	D3	L1	L2	A	B	
F15A16	15	15	21	64	6	16°	0°	

Fabry Bestell Nr:	Alte-Nr.	Bohrung Form	Bohrung	Stufung	Bemerkungen
Standard		Rund D			
F15A16D00.50...08.50G	76-00580	ø0.50 - ø8.50	Glatt	0.50 mm	
F15A16D09.00...12.00R	76-00580	ø9.00 - ø12.00	Rillen	0.50 mm	
Lieferbare Varianten		Rund D			
F15A16D00.05...12.00G	76-00580	ø0.50 - ø12.00	Glatt	0.01 mm	
F15A16D09.00...12.70R	76-00580	ø9.00- ø12.70	Rillen	0.01 mm	
F15A16D09.00...11.00RR	76-00580	ø9.00 - ø11.00	Riffelung	0.01 mm	
Lieferbare Varianten		Sechskant SK			
F15A16SK02.00...10.00G	76-00580	2.00 - 10.00	Glatt	0.01 mm	
Lieferbare Varianten		Vierkant VK			
F15A16VK02.00...08.00G	76-00580	2.00 - 8.00	Glatt	0.01 mm	

Für grössere Mengen und für andere Ausführungen kontaktieren Sie bitte unseren Verkauf

Tel: +41 61 935 93 00, verkauf@fabry.ch, www.fabry.ch



Schnabelspannzangen Typ F15A16



Einheitsnummer -

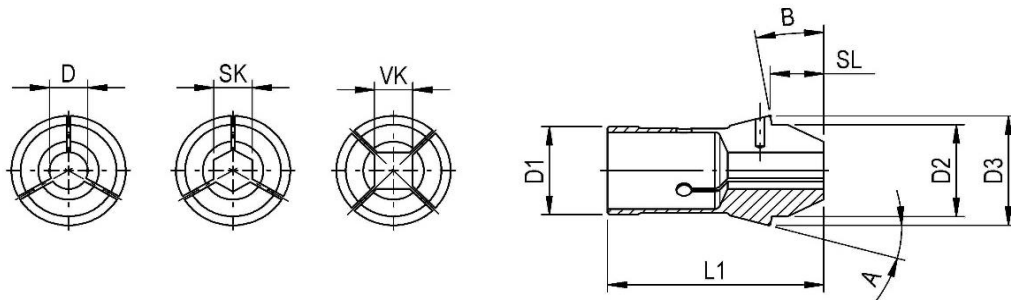

Spezifikation	D1	D2	D3	L1	SL	A	B
F15A16SL13	15	15	21	71	13	16°	0°

Fabry Bestell Nr:	Alte-Nr.	Bohrung Form	Bohrung	Stufung	Bemerkungen
Lieferbare Varianten	Rund D				
F15A16SL13D00.50...11.00	76-02022	∅0.50 - ∅11.00	Glatt	0.01 mm	Schnabellänge 13 mm

Für grössere Mengen und für andere Ausführungen kontaktieren Sie bitte unseren Verkauf

Tel: +41 61 935 93 00, verkauf@fabry.ch, www.fabry.ch

Spezifikation
Spannzangen



FABRY AG

SPANNZANGEN-TECHNOLOGIE
CNC-Bearbeitung Drehen Fräsen Schleifen

Spannzangen Typ F15A20



Einheitsnummer 121 E

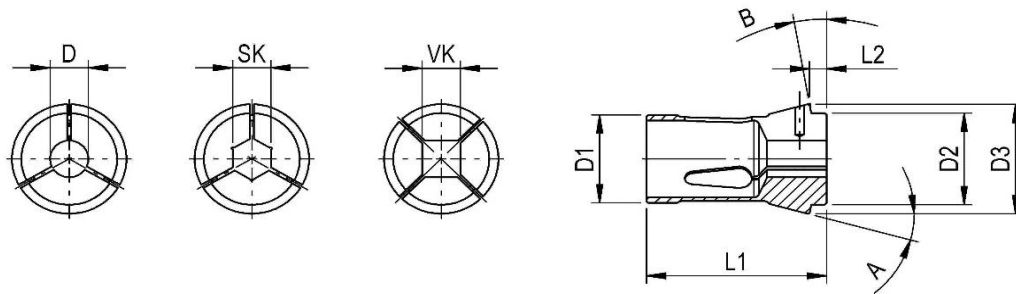

Spezifikation	D1	D2	D3	L1	L2	A	B	
F15A20	15	15	22	47	5	20°	0°	

Fabry Bestell Nr:	Alte-Nr.	Bohrung Form	Bohrung	Stufung	Bemerkungen
Standard		Rund D			
F15A20D02.00...08.50G	76-00358	ø2.00 - ø8.50	Glatt	0.50 mm	
F15A20D09.00...10.00R	76-00358	ø9.00 - ø10.00	Rillen	0.50 mm	
Lieferbare Varianten		Rund D			
F15A20D00.50...11.00G	76-00358	ø0.50 - ø11.00	Glatt	0.01 mm	
F15A20D09.00...11.00R	76-00358	ø9.00 - ø11.00	Rillen	0.01 mm	
F15A20D09.00...10.00RR	76-00358	ø9.00 - ø10.00	Riffelung	0.01 mm	
Lieferbare Varianten		Sechskant SK			
F15A20SK02.00...10.00G	76-00358	2.00 - 10.00	Glatt	0.01 mm	
Lieferbare Varianten		Vierkant VK			
F15A20VK02.00...08.00G	76-00358	2.00 - 8.00	Glatt	0.01 mm	

Für grössere Mengen und für andere Ausführungen kontaktieren Sie bitte unseren Verkauf

Tel: +41 61 935 93 00, verkauf@fabry.ch, www.fabry.ch

Spezifikation
Spannzangen



FABRY AG

SPANNZANGEN-TECHNOLOGIE
CNC-Bearbeitung Drehen Fräsen Schleifen

Spannzangen Typ F16A15



Einheitsnummer 123 E

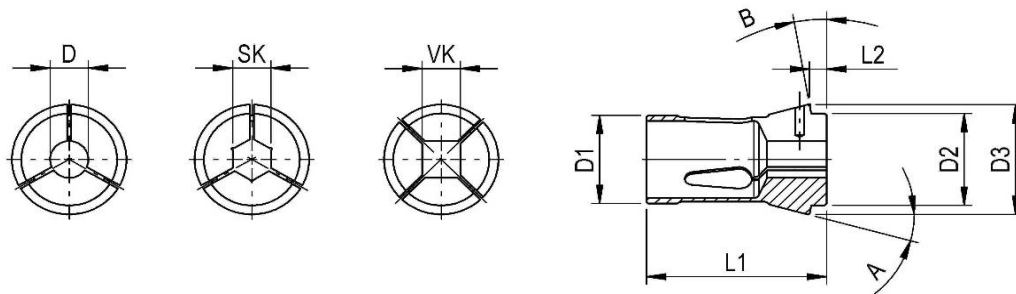

Spezifikation	D1	D2	D3	L1	L2	A	B	
F16A15	16	16	22	55	5	15°	0°	

Fabry Bestell Nr:	Alte-Nr.	Bohrung Form	Bohrung	Stufung	Bemerkungen
Standard		Rund D			
F16A15D00.50...08.50G	76-00104	ø0.50 - ø8.50	Glatt	0.50 mm	
F16A15D09.00...13.00R	76-00104	ø9.00 - ø13.00	Rillen	0.50 mm	
Lieferbare Varianten		Rund D			
F16A15D00.50...13.00G	76-00104	ø0.50 - ø13.00	Glatt	0.01 mm	
F16A15D09.00...13.00R	76-00104	ø9.00 - ø13.00	Rillen	0.01 mm	
F16A15D09.00...12.00RR	76-00104	ø9.00 - ø12.00	Riffelung	0.01 mm	
Lieferbare Varianten		Sechskant SK			
F16A15SK02.00...11.00G	76-00104	2.00 - 11.00	Glatt	0.01 mm	
Lieferbare Varianten		Vierkant VK			
F16A15VK04.00...09.00G	76-00104	4.00 - 9.00	Glatt	0.01 mm	
Notfall					
F16A15ND02.00V	76-52438	Vorbohrung ø2.0mm			Notfallzange Kopf weich

Für grössere Mengen und für andere Ausführungen kontaktieren Sie bitte unseren Verkauf

Tel: +41 61 935 93 00, verkauf@fabry.ch, www.fabry.ch

Spezifikation
Spannzangen



FABRY AG

SPANNZANGEN-TECHNOLOGIE
CNC-Bearbeitung Drehen Fräsen Schleifen

Spannzangen Typ F16A16



Einheitsnummer 1212 E

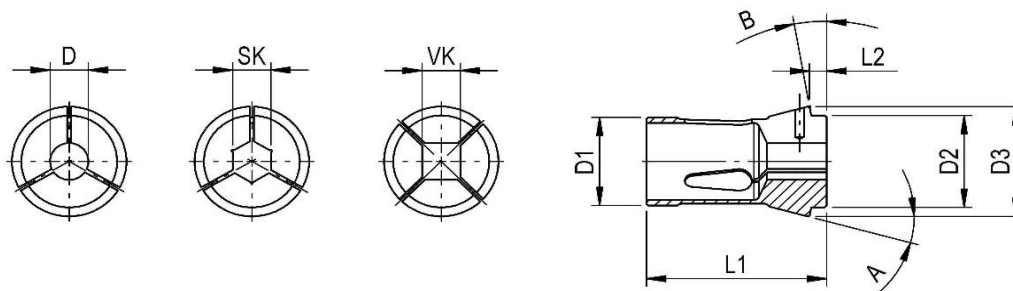

Spezifikation	D1	D2	D3	L1	L2	A	B
F16A16	16	16	21	64	6	16°	0°

Fabry Bestell Nr:	Alte-Nr.	Bohrung Form	Bohrung	Stufung	Bemerkungen
Standard		Rund D			
F16A16D00.50...08.50G	76-01076	ø00.50 - ø8.50	Glatt	0.50 mm	
F16A16D09.00...13.00R	76-01076	ø9.00 - ø13.00	Rillen	0.50 mm	
Lieferbare Varianten		Rund D			
F16A16D00.50...13.00G	76-01076	ø0.50 - ø13.00	Glatt	0.01 mm	
F16A16D09.00...13.00R	76-01076	ø9.00 - ø13.00	Rillen	0.01 mm	
F16A16D09.00...12.00RR	76-01076	ø9.00 - ø12.00	Riffelung	0.01 mm	
Lieferbare Varianten		Sechskant SK			
F16A16SK02.00...11.00G	76-01076	2.00 - 11.00	Glatt	0.01 mm	
Lieferbare Varianten		Vierkant VK			
F16A16VK04.00...09.00G	76-01076	4.00 - 9.00	Glatt	0.01 mm	

Für grössere Mengen und für andere Ausführungen kontaktieren Sie bitte unseren Verkauf

Tel: +41 61 935 93 00, verkauf@fabry.ch, www.fabry.ch

Spezifikation
Spannzangen



FABRY AG
SPANNZANGEN-TECHNOLOGIE
CNC-Bearbeitung Drehen Fräsen Schleifen

Schnabelspannzangen Typ F16A16



Einheitsnummer -

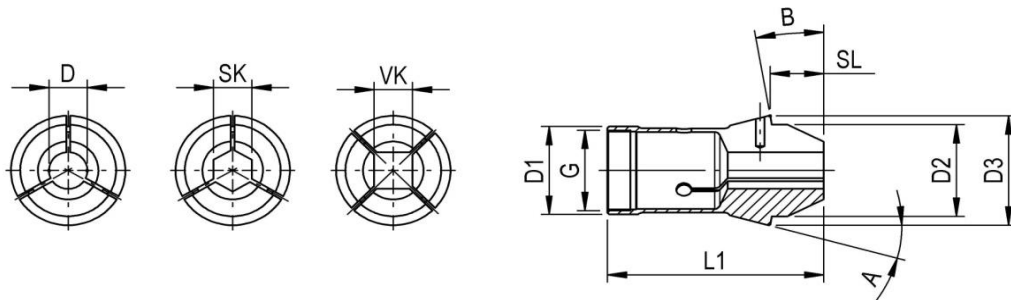

Spezifikation	D1	D2	D3	L1	SL	A	B	G
F16A16SL8...M14X0.75	16	16	21	66	8	16°	0°	M14x0.75
F16A16SL13...M14X0.75	16	16	21	71	13	16°	0°	M14x0.75

Fabry Bestell Nr:	Alte-Nr.	Bohrung Form	Bohrung	Stufung	Bemerkungen
Standard		Rund D			
F16A16SL8D01.00...13.00M14X0.75	76-00830	ø1.00 - ø13.00	Glatt	0.5 mm	Schnabellänge 8 mm
Lieferbare Varianten		Rund D			
F16A16SL8D00.50...13.10M14X0.75	76-00830	ø0.50 - ø13.10	Glatt	0.01 mm	Schnabellänge 8 mm
F16A16SL13D00.50...12.10M14X0.75	76-02015	ø0.50 - ø12.10	Glatt	0.01 mm	Schnabellänge 13 mm

Für grössere Mengen und für andere Ausführungen kontaktieren Sie bitte unseren Verkauf

Tel: +41 61 935 93 00, verkauf@fabry.ch, www.fabry.ch

Spezifikation Spannzangen



FABRY AG

SPANNZANGEN-TECHNOLOGIE
CNC-Bearbeitung Drehen Fräsen Schleifen

Spannzangen Typ F20A15

FAB

Einheitsnummer 136 E

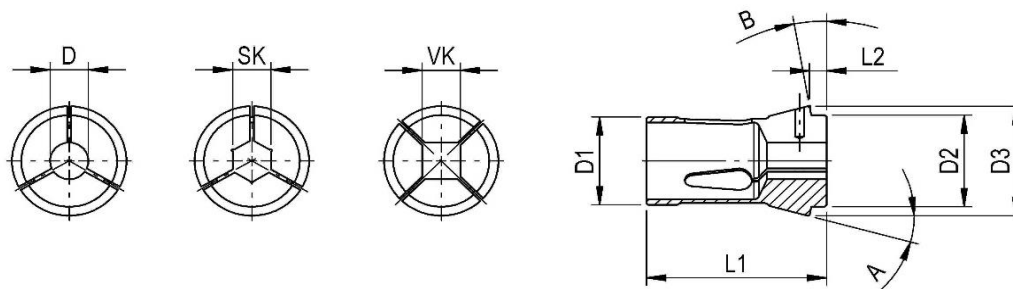

Spezifikation	D1	D2	D3	L1	L2	A	B
F20A15	20	19	26	54	5	15°	0°
F20A15NZL15	20	19	26	64	15	15°	0°

Fabry Bestell Nr:	Alte-Nr.	Bohrung Form	Bohrung	Stufung	Bemerkungen
Standard		Rund D			
F20A15D00.50...16.00G	76-00201	ø0.50 - ø16.00	Glatt	0.50 mm	
F20A15D09.00...16.00R	76-00201	ø9.00 - ø16.00	Rillen	0.50 mm	
Lieferbare Varianten		Rund D			
F20A15D00.50...16.80G	76-00201	ø0.50 - ø16.80	Glatt	0.01 mm	
F20A15D09.00...16.50R	76-00201	ø9.00 - ø16.50	Rillen	0.01 mm	
F20A15D09.00...16.00RR	76-00201	ø9.00 - ø16.00	Riffelung	0.01 mm	
Standard		Sechskant SK			
F20A15SK04.00...14.00G	76-00201	4.00 - 14.00	Glatt	1.0 mm	
Lieferbare Varianten		Sechskant SK			
F20A15SK02.00...14.50G	76-00201	2.00 - 14.50	Glatt	0.01 mm	
Standard		Vierkant VK			
F20A15VK04.00...08.00G	76-00201	4.00 - 8.00	Glatt	1.0 mm	
Lieferbare Varianten		Vierkant VK			
F20A15VK03.00...12.00G	76-00201	3.00 - 12.00	Glatt	0.01 mm	
Notfall					
F20A15NZL15D02.50V	76-53003	Vorbohrung ø2.5mm			Notfallzange Kopf weich

Für grössere Mengen und für andere Ausführungen kontaktieren Sie bitte unseren Verkauf

Tel: +41 61 935 93 00, verkauf@fabry.ch, www.fabry.ch



Schnabelspannzangen Typ F20A15



Einheitsnummer -

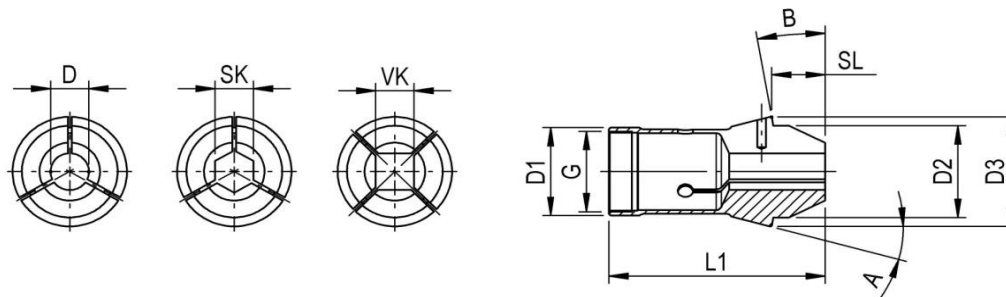

Spezifikation	D1	D2	D3	L1	SL	A	B	G
F20A15SL13...M18X1	20	19	26	62	13	15°	0°	M18x1

Fabry Bestell Nr:	Alte-Nr.	Bohrung Form	Bohrung	Stufung	Bemerkungen
Lieferbare Varianten		Rund D			
F20A15SL13D01.00...15.00M18X1	76-02016	ø1.00 - ø15.00	Glatt	0.01 mm	Schnabellänge 13 mm

Für grössere Mengen und für andere Ausführungen kontaktieren Sie bitte unseren Verkauf

Tel: +41 61 935 93 00, verkauf@fabry.ch, www.fabry.ch

Spezifikation
Spannzangen



FABRY AG

SPANNZANGEN-TECHNOLOGIE
CNC-Bearbeitung Drehen Fräsen Schleifen

Spannzangen Typ F20A16



Einheitsnummer 138 E

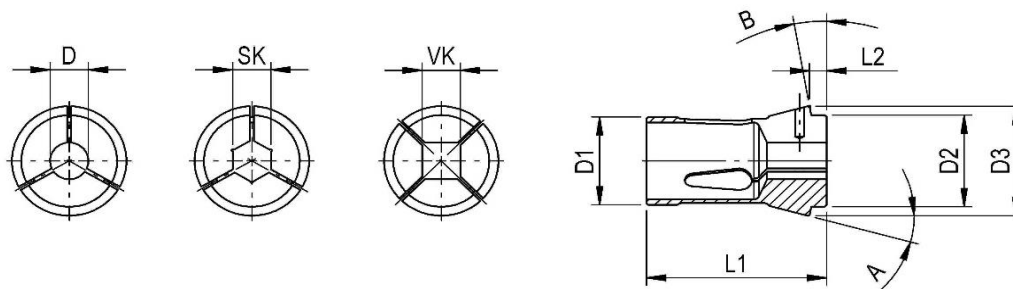

Spezifikation	D1	D2	D3	L1	L2	A	B	
F20A16	20	21	28	67	7	16°	0°	

Fabry Bestell Nr:	Alte-Nr.	Bohrung Form	Bohrung	Stufung	Bemerkungen
Standard		Rund D			
F20A16D00.50...16.00G	76-00087	ø0.50 - ø16.00	Glatt	0.50 mm	
F20A16D09.00...16.00R	76-00087	ø9.00 - ø16.00	Rillen	0.50 mm	
Lieferbare Varianten		Rund D			
F20A16D00.50...16.80G	76-00087	ø0.50 - ø16.80	Glatt	0.01 mm	
F20A16D09.00...17.00R	76-00087	ø9.00 - ø17.00	Rillen	0.01 mm	
F20A16D09.00...16.00RR	76-00087	ø9.00 - ø16.00	Riffelung	0.01 mm	
Standard		Sechskant SK			
F20A16SK04.00...14.00G	76-00087	4.00 - 14.00	Glatt	1.0 mm	
Lieferbare Varianten		Sechskant SK			
F20A16SK02.00...14.50G	76-00087	2.00 - 14.50	Glatt	0.01 mm	
Standard		Vierkant VK			
F20A16VK04.00...08.00G	76-00087	4.00 - 8.00	Glatt	1.0 mm	
Lieferbare Varianten		Vierkant VK			
F20A16VK04.00...12.00G	76-00087	4.00 - 12.00	Glatt	0.01 mm	

Für grössere Mengen und für andere Ausführungen kontaktieren Sie bitte unseren Verkauf

Tel: +41 61 935 93 00, verkauf@fabry.ch, www.fabry.ch



Schnabelspannzangen Typ F20A16



Einheitsnummer -

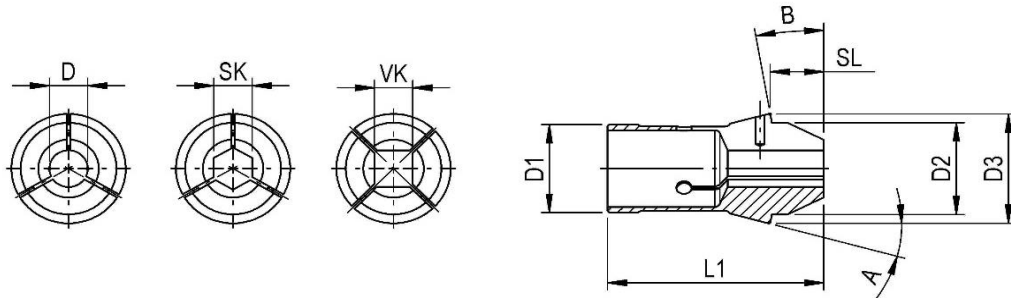

Spezifikation	D1	D2	D3	L1	SL	A	B	
F20A16SL15	20	21	28	75	15	16°	0°	
F20A16SL20	20	21	28	80	20	16°	0°	

Fabry Bestell Nr:	Alte-Nr.	Bohrung Form	Bohrung	Stufung	Bemerkungen
Standard		Rund D			
F20A16SL15D01.00...16.00G	76-02017	ø1.00 - ø16.00	Glatt	0.5 mm	Schnabellänge 15 mm
F20A16SL20D00.50...16.00G	76-02027	ø0.50 - ø16.00	Glatt	0.5 mm	Schnabellänge 20 mm
Lieferbare Varianten		Rund D			
F20A16SL15D01.00...16.00G	76-02017	ø1.00 - ø16.00	Glatt	0.01 mm	Schnabellänge 15 mm
F20A16SL20D00.98...16.50G	76-02027	ø0.98 - ø16.50	Glatt	0.01 mm	Schnabellänge 20 mm

Für grössere Mengen und für andere Ausführungen kontaktieren Sie bitte unseren Verkauf

Tel: +41 61 935 93 00, verkauf@fabry.ch, www.fabry.ch

Spezifikation
Spannzangen



FABRY AG

SPANNZANGEN-TECHNOLOGIE
CNC-Bearbeitung Drehen Fräsen Schleifen

Spannzangen Typ F22



Einheitsnummer -

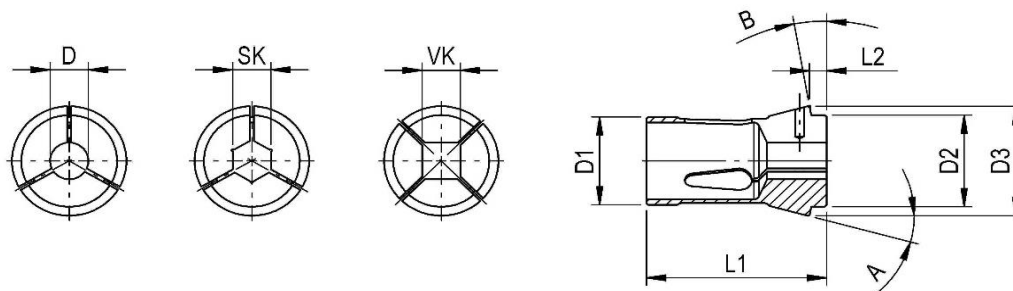

Spezifikation	D1	D2	D3	L1	L2	A	B	
F22	22	21	30	55	6	15°	10°	

Fabry Bestell Nr:	Alte-Nr.	Bohrung Form	Bohrung	Stufung	Bemerkungen
Standard		Rund D			
F22D01.00...08.50G	76-00071	ø1.00 - ø8.50	Glatt	0.50 mm	
F22D09.00...16.00R	76-00071	ø9.00 - ø16.00	Rillen	0.50 mm	
Lieferbare Varianten		Rund D			
F22D01.00...16.00G	76-00071	ø1.00 - ø16.00	Glatt	0.01 mm	
F22D09.00...17.50R	76-00071	ø9.00 - ø17.50	Rillen	0.01 mm	
F22D09.00...15.00RR	76-00071	ø9.00 - ø15.00	Riffelung	0.01 mm	
Lieferbare Varianten		Sechskant SK			
F22SK03.00...14.00G	76-00071	3.00 - 14.00	Glatt	0.01 mm	
Lieferbare Varianten		Vierkant VK			
F22VK04.00...12.00G	76-00071	4.00 - 12.00	Glatt	0.01 mm	

Für grössere Mengen und für andere Ausführungen kontaktieren Sie bitte unseren Verkauf

Tel: +41 61 935 93 00, verkauf@fabry.ch, www.fabry.ch



Schnabelspannzangen Typ F22



Einheitsnummer -

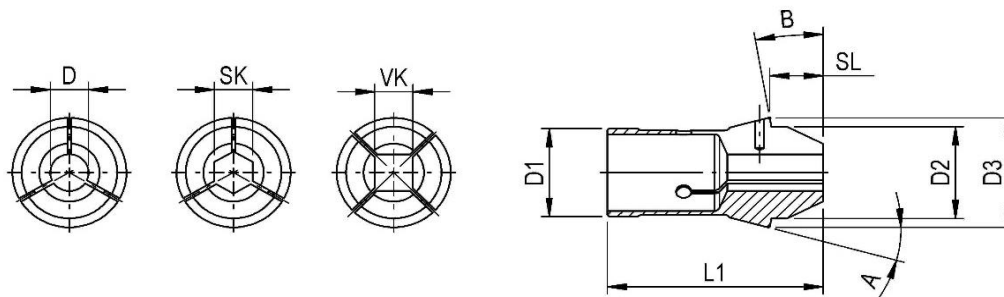

Spezifikation	D1	D2	D3	L1	SL	A	B
F22SL16	22	21	30	65	16	15°	10°

Fabry Bestell Nr:	Alte-Nr.	Bohrung Form	Bohrung	Stufung	Bemerkungen
Lieferbare Varianten		Rund D			
F22SL16D01.00...16.00G		ø1.00 - ø16.00	Glatt	0.01 mm	Schnabellänge 16 mm

Für grössere Mengen und für andere Ausführungen kontaktieren Sie bitte unseren Verkauf

Tel: +41 61 935 93 00, verkauf@fabry.ch, www.fabry.ch

Spezifikation
Spannzangen



FABRY AG

SPANNZANGEN-TECHNOLOGIE
CNC-Bearbeitung Drehen Fräsen Schleifen

Spannzangen Typ F25



Einheitsnummer 145 E

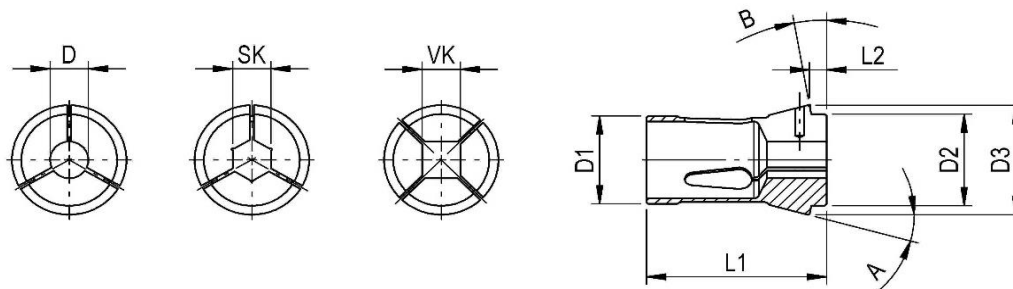

Spezifikation	D1	D2	D3	L1	L2	A	B
F25	25	27	35	77	10	16°	0°
F25NZL18	25	27	35	77	18	16°	0°

Fabry Bestell Nr:	Alte-Nr.	Bohrung Form	Bohrung	Stufung	Bemerkungen
Standard		Rund D			
F25D00.50...20.00G	76-00064	ø00.50 - ø20.00	Glatt	0.50 mm	
F25D09.00...20.00R	76-00064	ø09.00 - ø20.00	Rillen	0.50 mm	
Lieferbare Varianten		Rund D			
F25D00.50...20.50G	76-00064	ø00.50 - ø20.50	Glatt	0.01 mm	
F25D09.00...20.50R	76-00064	ø09.00 - ø20.50	Rillen	0.01 mm	
F25D09.00...20.00RR	76-00064	ø09.00 - ø20.00	Riffelung	0.01 mm	
Standard		Sechskant SK			
F25SK04.00...18.00G	76-00064	04.00 - 18.00	Glatt	1.0 mm	
Lieferbare Varianten		Sechskant SK			
F25SK02.00...18.00G	76-00064	02.00 - 18.00	Glatt	0.01 mm	
Standard		Vierkant VK			
F25VK04.00...15.00G	76-00064	04.00 - 15.00	Glatt	1.0 mm	
Lieferbare Varianten		Vierkant VK			
F25VK04.00...15.00G	76-00064	04.00 - 15.00	Glatt	0.01 mm	
Notfall					
F25NZL18D03.00V	76-53004	Vorbohrung ø3mm			Notfallzange Kopf weich

Für grössere Mengen und für andere Ausführungen kontaktieren Sie bitte unseren Verkauf

Tel: +41 61 935 93 00, verkauf@fabry.ch, www.fabry.ch



Schnabelspannzangen Typ F25



Einheitsnummer -

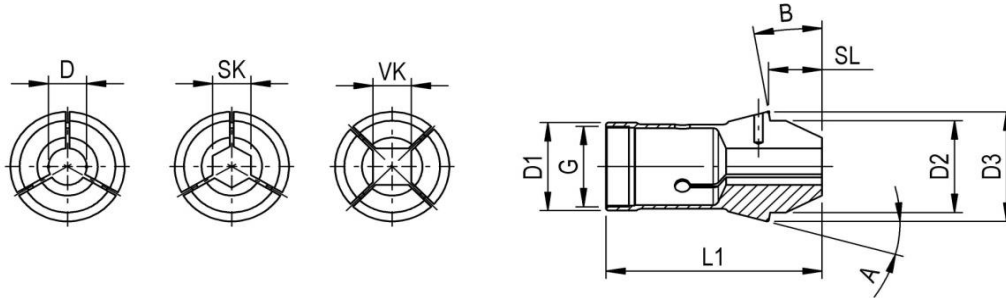

Spezifikation	D1	D2	D3	L1	SL	A	B	G
F25SL18...M22X1	25	27	35	85	18	16°	0°	M22x1
F25SL25	25	27	35	92	25	16°	0°	

Fabry Bestell Nr:	Alte-Nr.	Bohrung Form	Bohrung	Stufung	Bemerkungen
Standard		Rund D			
F25SL18D01.00...20.00GM22X1	76-02018	ø1.00 - ø20.00	Glatt	0.5 mm	Schnabellänge 18 mm
F25SL25D01.00...20.00G		ø1.00 - ø20.00	Glatt	0.5 mm	Schnabellänge 25 mm
Lieferbare Varianten		Rund D			
F25SL18D00.98...20.80GM22X1	76-02018	ø0.98 - ø20.80	Glatt	0.01 mm	Schnabellänge 18 mm
F25SL25D00.98...20.80G		ø0.98 - ø20.80	Glatt	0.01 mm	Schnabellänge 25 mm

Für grössere Mengen und für andere Ausführungen kontaktieren Sie bitte unseren Verkauf

Tel: +41 61 935 93 00, verkauf@fabry.ch, www.fabry.ch

Spezifikation
Spannzangen



FABRY AG

SPANNZANGEN-TECHNOLOGIE
CNC-Bearbeitung Drehen Fräsen Schleifen

Restposten Spannzangen Typ F25 - F39



Einheitsnummer -

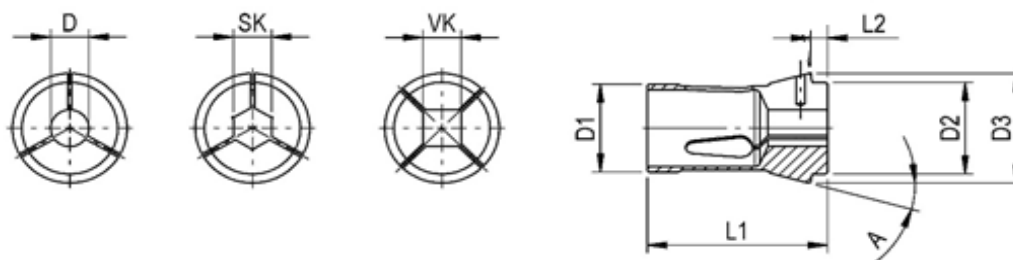

Spezifikation	D1	D2	D3	L1	L2	A	
F25(76-01778)	25	25	30	34	3	15°	
F25(76-00091)	25	25	34	65	6	15°	
F26(76-01703)	26	-	34	67	-	20°	
F32(76-01023)	32	34	40	65	6	15°	
F34(76-01077)	34	37	44	80	9.6	16°	
F35(76-00067)	35	34	43	70	7	15°	
F35(76-00612)für Manurin	35	32	40	47	6.3	15°	Schaftbohrung ø 29
F35(76-00612)für Tornos	35	32	40	47	6.4	15°	Schaftbohrung ø 32
F39(76-01208)	39	39.5	46	80	9	15°	

Fabry Bestell Nr:	Alte-Nr.	Bohrung	Form	Stufung	Bemerkungen
F25(76-01778)	76-01778	ø02.00 - ø19.50	Rund	0.50 mm	Restposten
F25(76-00091)	76-00091	ø01.50 - ø21.00	Rund	0.50 mm	Restposten
F25SK(76-00091)	76-00091	SK04.00 - SK19.00	6-Kant	1.0 mm	Restposten
F26(76-01703)	76-01703	ø06.00 - ø20.00	Rund	0.50 mm	Restposten
F32(76-01023)	76-01023	ø05.00 - ø26.00	Rund	0.50 mm	Restposten
F32SK(76-01023)	76-01023	SK05.00 - SK22.00	6-Kant	1.0 mm	Restposten
F35(76-00067)	76-00067	ø02.00 - ø30.00	Rund	0.50 mm	Restposten
F35VK(76-00067)	76-00067	VK04.00 - VK18.00	4-Kant	1.0 mm	Restposten
F35SK(76-00067)	76-00067	SK05.00 - SK22.00	6-Kant	1.0 mm	Restposten
F34(76-01077)	76-01077	ø05.00 - ø20.00	Rund	1.0 mm	Restposten
F35(76-00612)für Manurin	76-00612	ø02.00 - ø29.00	Rund	0.50 mm	Restposten
F35(76-00612)für Tornos	76-00612	ø03.00 - ø29.00	Rund	0.50 mm	Restposten
F39(76-01208)	76-01208	ø10.00 - ø30.50	Rund	0.50 mm	Restposten
F39VK(76-01208)	76-01208	VK08.00 - VK21.00	4-Kant	1.0 mm	Restposten
F39SK(76-01208)	76-01208	SK12.00 - VK24.00	6-Kant	1.0 mm	Restposten

Für grössere Mengen und für andere Ausführungen kontaktieren Sie bitte unseren Verkauf

Tel: +41 61 935 93 00, verkauf@fabry.ch, www.fabry.ch

Spezifikation
Spannzangen



FABRY AG

SPANNZANGEN-TECHNOLOGIE
CNC-Bearbeitung Drehen Fräsen Schleifen

Spannzangen Typ F26



Einheitsnummer 146 E

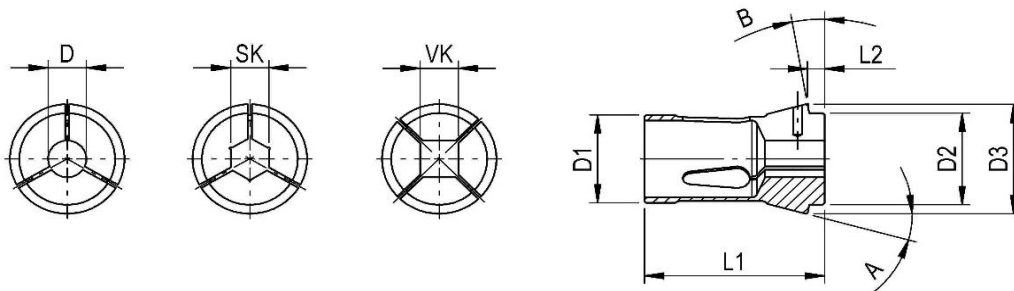

Spezifikation	D1	D2	D3	L1	L2	A	B	
F26	26	27.5	32	67	7	13°	10°	

Fabry Bestell Nr:	Alte-Nr.	Bohrung Form	Bohrung	Stufung	Bemerkungen
Standard		Rund D			
F26D02.50...20.00G	76-00090	ø02.50 - ø20.00	Glatt	0.50 mm	
Lieferbare Varianten		Rund D			
F26D02.50...20.00G	76-00090	ø02.50 - ø20.00	Glatt	0.01 mm	
F26D08.50...20.00R	76-00090	ø08.50 - ø20.00	Rillen	0.01 mm	
F26D09.00...19.00RR	76-00090	ø09.00 - ø19.00	Riffelung	0.01 mm	
Lieferbare Varianten		Sechskant SK			
F26SK03.00...18.00G	76-00090	3.00 - 18.00	Glatt	0.01 mm	
Lieferbare Varianten		Vierkant VK			
F26VK05.00...12.00G	76-00090	5.00 - 12.00	Glatt	0.01 mm	

Für grössere Mengen und für andere Ausführungen kontaktieren Sie bitte unseren Verkauf

Tel: +41 61 935 93 00, verkauf@fabry.ch, www.fabry.ch

Spezifikation
Spannzangen



FABRY AG

SPANNZANGEN-TECHNOLOGIE
CNC-Bearbeitung Drehen Fräsen Schleifen

Spannzangen Typ F27



Einheitsnummer 147 E

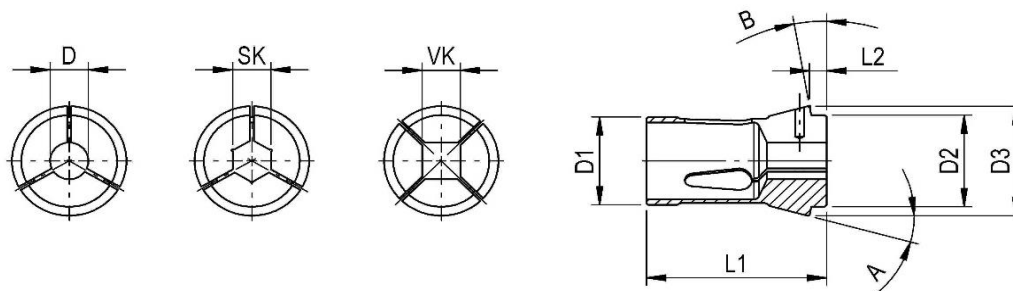

Spezifikation	D1	D2	D3	L1	L2	A	B
F27	27	30	38	72.7	8	15°	7°

Fabry Bestell Nr:	Alte-Nr.	Bohrung Form	Bohrung	Stufung	Bemerkungen
Standard		Rund D			
F27D01.00...08.50G	76-00022	ø1.00 - ø8.50	Glatt	0.50 mm	
F27D09.00...23.00R	76-00022	ø9.00 - ø23.00	Rillen	0.50 mm	
Lieferbare Varianten		Rund D			
F27D00.50...23.00G	76-00022	ø0.50 - ø23.00	Glatt	0.01 mm	
F27D09.00...23.00R	76-00022	ø9.00 - ø23.00	Rillen	0.01 mm	
F27D09.00...21.00RR	76-00022	ø9.00 - ø21.00	Riffelung	0.01 mm	
Standard		Sechskant SK			
F27SK04.00...20.00G	76-00022	4.00 - 20.00	Glatt	1.0 mm	
Lieferbare Varianten		Sechskant SK			
F27SK02.00...20.00G	76-00022	2.00 - 20.00	Glatt	0.01 mm	
Standard		Vierkant VK			
F27VK04.00...16.00G	76-00022	4.00 - 16.00	Glatt	1.0 mm	
Lieferbare Varianten		Vierkant VK			
F27VK04.00...16.00G	76-00022	4.00 - 16.00	Glatt	0.01 mm	
Notfall					
F27ND03.00V	76-52353	Vorbohrung ø3mm			Notfallzange Kopf weich

Für grössere Mengen und für andere Ausführungen kontaktieren Sie bitte unseren Verkauf

Tel: +41 61 935 93 00, verkauf@fabry.ch, www.fabry.ch



Schnabelspannzangen Typ F27



Einheitsnummer -

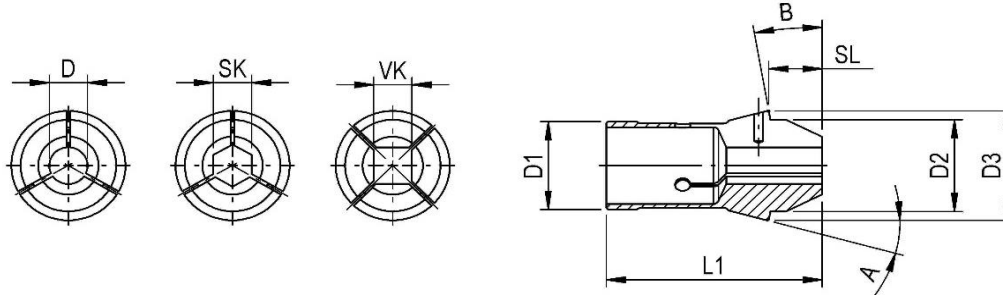

Spezifikation	D1	D2	D3	L1	SL	A	B
F27SL18.3	27	30	28	83	18.3	15°	7°

Fabry Bestell Nr:	Alte-Nr.	Bohrung Form	Bohrung	Stufung	Bemerkungen
Standard		Rund D			
F27SL18.3D03.00...15.00G	76-02040	ø03.00 - ø15.00	Glatt	0.5 mm	Schnabellänge 18.3 mm
Lieferbare Varianten		Rund D			
F27SL18.3D03.00...15.00G	76-02040	ø03.00 - ø15.00	Glatt	0.01 mm	Schnabellänge 18.3 mm

Für grössere Mengen und für andere Ausführungen kontaktieren Sie bitte unseren Verkauf

Tel: +41 61 935 93 00, verkauf@fabry.ch, www.fabry.ch

Spezifikation
Spannzangen



FABRY AG

SPANNZANGEN-TECHNOLOGIE
CNC-Bearbeitung Drehen Fräsen Schleifen

Spannzangen Typ F28



Einheitsnummer 148 E

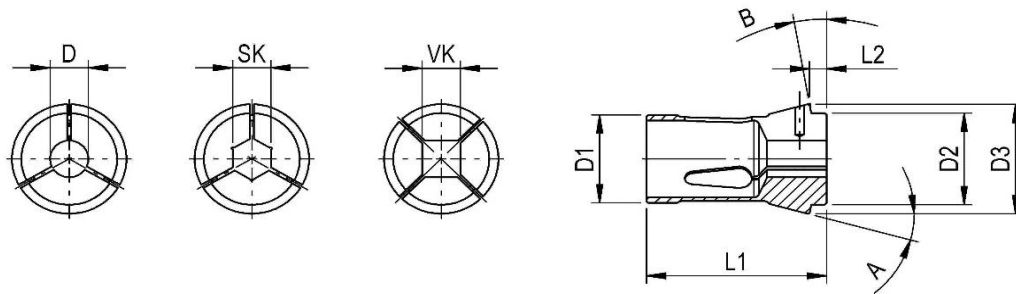

Spezifikation	D1	D2	D3	L1	L2	A	B
F28	28	28	38	70	7	15°	10°

Fabry Bestell Nr:	Alte-Nr.	Bohrung Form	Bohrung	Stufung	Bemerkungen
Standard		Rund D			
F28D01.00...8.50G	76-00093	ø1.00 - ø8.50	Glatt	0.50 mm	
F28D09.00...23.00R	76-00093	ø9.00 - ø23.00	Rillen	1.0 mm	
Lieferbare Varianten		Rund D			
F28D01.00...23.00G	76-00093	ø1.00 - ø23.00	Glatt	0.01 mm	
F28D09.00...23.00R	76-00093	ø9.00 - ø23.00	Rillen	0.01 mm	
F28D09.00...22.00RR	76-00093	ø9.00 - ø22.00	Riffelung	0.01 mm	
Lieferbare Varianten		Sechskant SK			
F28SK02.00...20.00G	76-00093	2.00 - 20.00	Glatt	0.01 mm	
Lieferbare Varianten		Vierkant VK			
F28VK04.00...16.00G	76-00093	4.00 - 16.00	Glatt	0.01 mm	

Für grössere Mengen und für andere Ausführungen kontaktieren Sie bitte unseren Verkauf

Tel: +41 61 935 93 00, verkauf@fabry.ch, www.fabry.ch

Spezifikation
Spannzangen



FABRY AG

SPANNZANGEN-TECHNOLOGIE
CNC-Bearbeitung Drehen Fräsen Schleifen

Spannzangen Typ F30A15



Einheitsnummer 1446 E

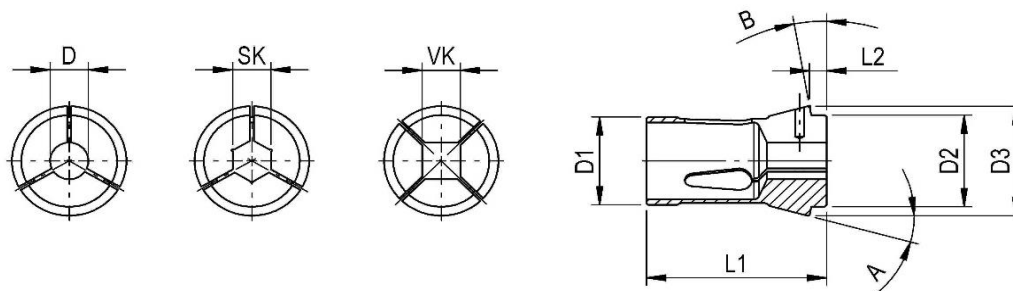

Spezifikation	D1	D2	D3	L1	L2	A	B
F30A15	30	32	38	65	6	15°	0°

Fabry Bestell Nr:	Alte-Nr.	Bohrung Form	Bohrung	Stufung	Bemerkungen
Standard		Rund D			
F30A15D01.00...26.00G	76-00101	ø01.00 - 26.00	Glatt	0.50 mm	
F30A15D09.00...26.00R	76-00101	ø09.00 - 26.00	Rillen	0.50 mm	
Lieferbare Varianten		Rund D			
F30A15D01.00...26.00G	76-00101	ø01.00 - 26.00	Glatt	0.01 mm	
F30A15D09.00...26.00R	76-00101	ø9.00 - 26.00	Rillen	0.01 mm	
F30A15D09.00...26.00RR	76-00101	ø9.00 - 26.00	Riffelung	0.01 mm	
Standard		Sechskant SK			
F30A15SK04.00...22.00G	76-00101	4.00 - 22.00	Glatt	1.0 mm	
Lieferbare Varianten		Sechskant SK			
F30A15SK04.00...22.00G	76-00101	4.00 - 22.00	Glatt	0.01 mm	
Standard		Vierkant VK			
F30A15VK05.00...18.00G	76-00101	5.00 - 18.00	Glatt	1.0 mm	
Lieferbare Varianten		Vierkant VK			
F30A15VK05.00...18.00G	76-00101	5.00 - 18.00	Glatt	0.01 mm	
Notfall					
F30A15ND03.00V	76-53005	Vorbohrung ø3mm			Notfallzange Kopf weich

Für grössere Mengen und für andere Ausführungen kontaktieren Sie bitte unseren Verkauf

Tel: +41 61 935 93 00, verkauf@fabry.ch, www.fabry.ch



Schnabelspannzangen Typ F30A15



Einheitsnummer -

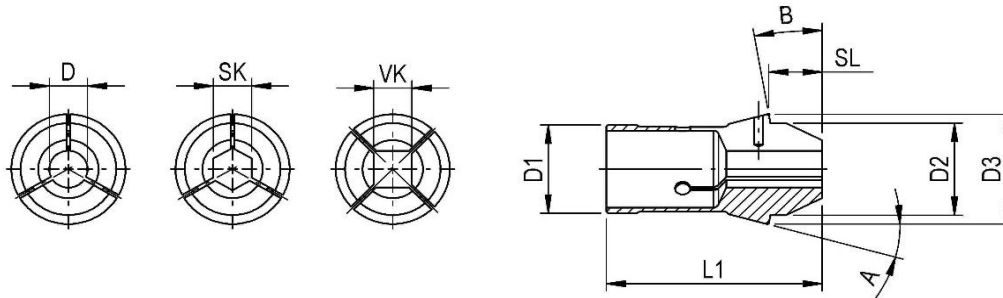

Spezifikation	D1	D2	D3	L1	SL	A	B	
F30A15SL16	30	32	38	75	16	15°	0°	
F30A15SL20	30	32	38	79	20	15°	0°	

Fabry Bestell Nr:	Alte-Nr.	Bohrung Form	Bohrung	Stufung	Bemerkungen
Standard		Rund D			
F30A15SL16D03.00...23.00G		ø3.00 - ø23.00	Glatt	0.5 mm	Schnabellänge 16 mm
Lieferbare Varianten		Rund D			
F30A15SL16D03.00...23.00G		ø3.00 - ø23.00	Glatt	0.01 mm	Schnabellänge 16 mm
F30A15SL20D02.00...25.40G	76-02019	ø2.00 - ø25.40	Glatt	0.01 mm	Schnabellänge 20 mm

Für grössere Mengen und für andere Ausführungen kontaktieren Sie bitte unseren Verkauf

Tel: +41 61 935 93 00, verkauf@fabry.ch, www.fabry.ch

Spezifikation
Spannzangen



FABRY AG

SPANNZANGEN-TECHNOLOGIE
CNC-Bearbeitung Drehen Fräsen Schleifen

Spannzangen Typ F30A16



Einheitsnummer 161 E

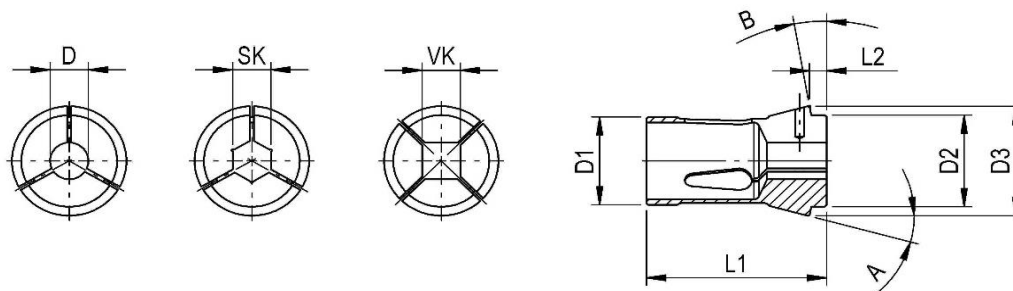

Spezifikation	D1	D2	D3	L1	L2	A	B
F30A16	30	34	42	80	10	16°	0°

Fabry Bestell Nr:	Alte-Nr.	Bohrung Form	Bohrung	Stufung	Bemerkungen
Standard		Rund D			
F30A16D01.00...8.50G	76-00063	ø1.00 - ø8.50	Glatt	0.50 mm	
F30A16D09.00...25.00G	76-00063	ø9.00 - ø25.00	Glatt	1.0 mm	
F30A16D09.00...25.00R	76-00063	ø9.00 - ø25.00	Rillen	0.50 mm	
Lieferbare Varianten		Rund D			
F30A16D00.98...26.00G	76-00063	ø0.98 - ø26.00	Glatt	0.01 mm	
F30A16D09.00...26.00R	76-00063	ø9.00 - ø26.00	Rillen	0.01 mm	
F30A16D09.00...24.00RR	76-00063	ø9.00 - ø24.00	Riffelung	0.01 mm	
Lieferbare Varianten		Sechskant SK			
F30A16SK04.00...22.00G	76-00063	4.00 - 22.00	Glatt	0.01 mm	
Lieferbare Varianten		Vierkant VK			
F30A16VK04.00...18.00G	76-00063	4.00 - 18.00	Glatt	0.01 mm	

Für grössere Mengen und für andere Ausführungen kontaktieren Sie bitte unseren Verkauf

Tel: +41 61 935 93 00, verkauf@fabry.ch, www.fabry.ch



Schnabelspannzangen Typ F30A16



Einheitsnummer -

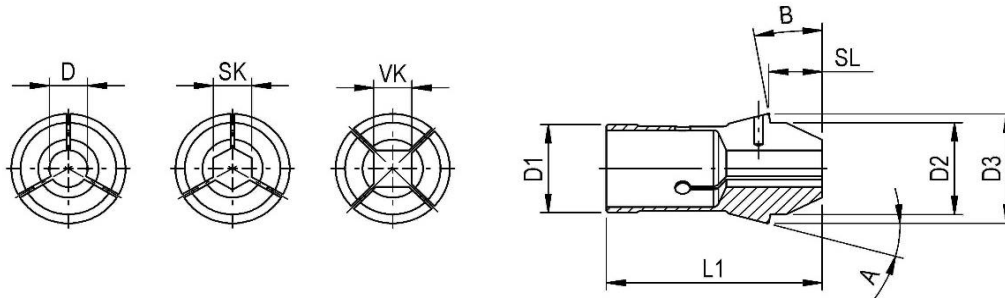

Spezifikation	D1	D2	D3	L1	SL	A	B	
F30A16SL25	30	34	42	95	25	16°	0°	

Fabry Bestell Nr:	Alte-Nr.	Bohrung Form	Bohrung	Stufung	Bemerkungen
Lieferbare Varianten		Rund D			
F30A16SL25D03.00...15.00G		ø3.00 - ø15.00	Glatt	0.01 mm	Schnabellänge 25 mm

Für grössere Mengen und für andere Ausführungen kontaktieren Sie bitte unseren Verkauf

Tel: +41 61 935 93 00, verkauf@fabry.ch, www.fabry.ch

Spezifikation
Spannzangen



FABRY AG
SPANNZANGEN-TECHNOLOGIE
CNC-Bearbeitung Drehen Fräsen Schleifen

Spannzangen Typ F32



Einheitsnummer 161 E

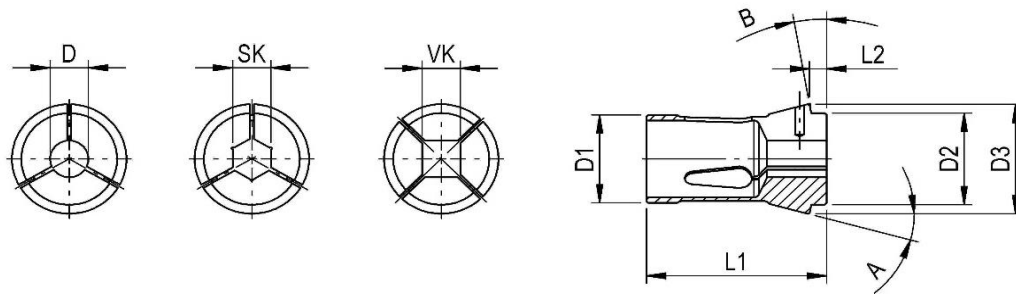

Spezifikation	D1	D2	D3	L1	L2	A	B	
F32	32	34	45	75	8	15	10	

Fabry Bestell Nr:	Alte-Nr.	Bohrung Form	Bohrung	Stufung	Bemerkungen
Standard		Rund D			
F32D01.00...8.50G	76-00221	ø1.00 - ø8.50	Glatt	0.50 mm	
F32D09.00...26.00G	76-00221	ø9.00 - ø26.00	Glatt	1.0 mm	
F32D09.00...26.00R	76-00221	ø9.00 - ø26.00	Rillen	0.50 mm	
Lieferbare Varianten		Rund D			
F32D00.98...27.05G	76-00221	ø0.98 - ø27.05	Glatt	0.01 mm	
F32D09.00...27.05R	76-00221	ø9.00 - ø27.05	Rillen	0.01 mm	
F32D09.00...26.00RR	76-00221	ø9.00 - ø26.00	Riffelung	0.01 mm	
Standard		Sechskant SK			
F32SK04.00...22.00G	76-00221	4.00 - 22.00	Glatt	1.0 mm	
Lieferbare Varianten		Sechskant SK			
F32SK02.00...23.00G	76-00221	2.00 - 23.00	Glatt	0.01 mm	
Standard		Vierkant VK			
F32VK04.00...18.00G	76-00221	4.00 - 18.00	Glatt	1.0 mm	
Lieferbare Varianten		Vierkant VK			
F32VK04.00...19.00G	76-00221	4.00 - 19.00	Glatt	0.01 mm	
Notfall					
F32ND03.00V	76-52639	Vorbohrung ø3mm			Notfallzange Kopf weich

Für grössere Mengen und für andere Ausführungen kontaktieren Sie bitte unseren Verkauf

Tel: +41 61 935 93 00, verkauf@fabry.ch, www.fabry.ch



Schnabelspannzangen Typ F32



Einheitsnummer -

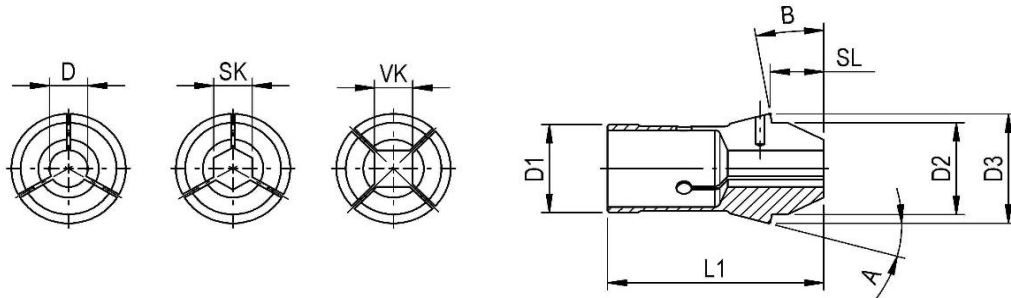

Spezifikation	D1	D2	D3	L1	SL	A	B	
F32SL23	32	34	45	90	23	15°	10°	

Fabry Bestell Nr:	Alte-Nr.	Bohrung Form	Bohrung	Stufung	Bemerkungen
Standard		Rund D			
F32SL23D02.00...22.00G		ø02.00 - ø22.00	Glatt	1.0 mm	Schnabellänge 23 mm
Lieferbare Varianten		Rund D			
F32SL23D02.00...22.00G		ø02.00 - ø22.00	Glatt	0.01 mm	Schnabellänge 23 mm

Für grössere Mengen und für andere Ausführungen kontaktieren Sie bitte unseren Verkauf

Tel: +41 61 935 93 00, verkauf@fabry.ch, www.fabry.ch

Spezifikation
Spannzangen



FABRY AG

SPANNZANGEN-TECHNOLOGIE
CNC-Bearbeitung Drehen Fräsen Schleifen

Spannzangen Typ F35



Einheitsnummer 163 E

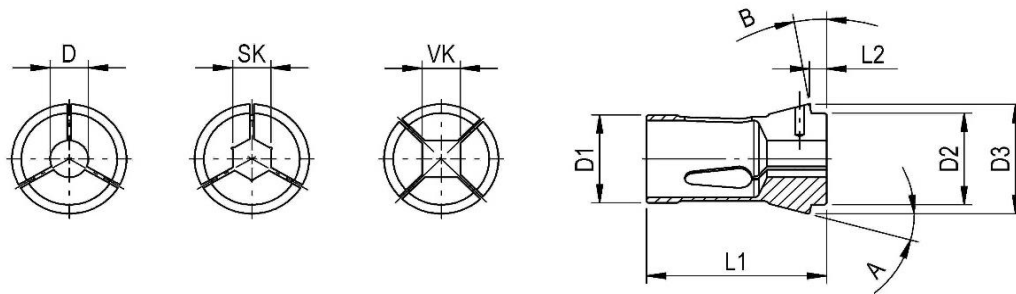

Spezifikation	D1	D2	D3	L1	L2	A	B	
F35	35	38	48	80	8	15°	10	

Fabry Bestell Nr:	Alte-Nr.	Bohrung Form	Bohrung	Stufung	Bemerkungen
Standard		Rund D			
F35D02.00...8.50G	76-00094	ø2.00 - ø8.50	Glatt	0.50 mm	
F35D09.00...30.00R	76-00094	ø9.00 - ø30.00	Rillen	0.50 mm	
Lieferbare Varianten		Rund D			
F35D00.98...30.05G	76-00094	ø0.98 - ø30.05	Glatt	0.01 mm	
F35D09.00...30.05R	76-00094	ø9.00 - ø30.05	Rillen	0.01 mm	
F35D09.00...29.00RR	76-00094	ø9.00 - ø29.00	Riffelung	0.01 mm	
Standard		Sechskant SK			
F35SK04.00...26.00G	76-00094	4.00 - 26.00	Glatt	1.0 mm	
Lieferbare Varianten		Sechskant SK			
F35SK02.00...26.00G	76-00094	2.00 - 26.00	Glatt	0.01 mm	
Standard		Vierkant VK			
F35VK04.00...21.00G	76-00094	4.00 - 21.00	Glatt	1.0 mm	
Lieferbare Varianten		Vierkant VK			
F35VK04.00...21.00G	76-00094	4.00 - 21.00	Glatt	0.01 mm	
Notfall					
F35ND03.00V	76-52636	Vorbohrung ø3mm			Notfallzange Kopf weich

Für grössere Mengen und für andere Ausführungen kontaktieren Sie bitte unseren Verkauf

Tel: +41 61 935 93 00, verkauf@fabry.ch, www.fabry.ch

Spezifikation
Spannzangen



FABRY AG

SPANNZANGEN-TECHNOLOGIE
CNC-Bearbeitung Drehen Fräsen Schleifen

Schnabelspannzangen Typ F35



Einheitsnummer -

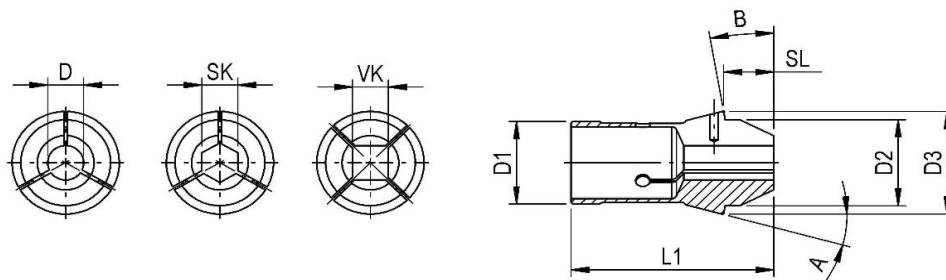

Spezifikation	D1	D2	D3	L1	SL	A	B
F35SL27	35	34	43	90	27	15°	

Fabry Bestell Nr:	Alte-Nr.	Bohrung Form	Bohrung	Stufung	Bemerkungen
Standard		Rund D			
F32SL23D03.00...22.00G	76-02013	ø03.00 - ø22.00	Glatt	1.0 mm	Schnabellänge 27 mm
Lieferbare Varianten		Rund D			
F32SL23D03.00...22.00G	76-02013	ø03.00 - ø22.00	Glatt	0.01 mm	Schnabellänge 27 mm

Für grössere Mengen und für andere Ausführungen kontaktieren Sie bitte unseren Verkauf

Tel: +41 61 935 93 00, verkauf@fabry.ch, www.fabry.ch

Spezifikation
Spannzangen



FABRY AG

SPANNZANGEN-TECHNOLOGIE
CNC-Bearbeitung Drehen Fräsen Schleifen

Spannzangen Typ F37



Einheitsnummer 1536 E

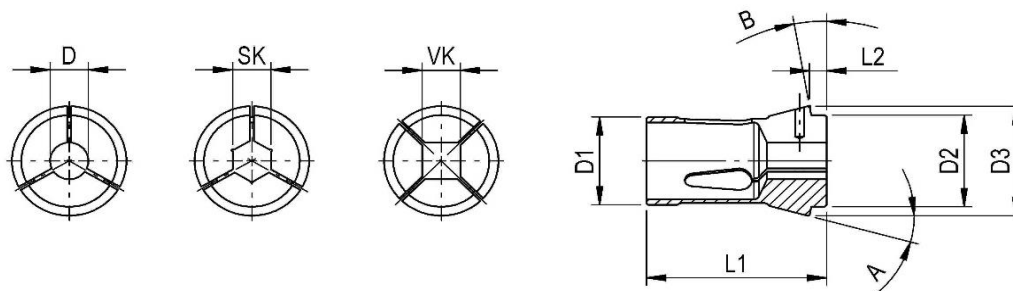

Spezifikation	D1	D2	D3	L1	L2	A	B
F37	37	40	47	92	10	16°	0°

Fabry Bestell Nr:	Alte-Nr.	Bohrung Form	Bohrung	Stufung	Bemerkungen
Standard		Rund D			
F37D01.00...32.00G	76-00740	ø1.00 - ø32.00	Glatt	0.50 mm	
F37D09.00...32.00R	76-00740	ø9.00 - ø32.00	Rillen	0.50 mm	
Lieferbare Varianten		Rund D			
F37D00.98...32.05G	76-00740	ø0.98 - ø32.05	Glatt	0.01 mm	
F37D09.00...32.05R	76-00740	ø9.00 - ø32.05	Rillen	0.01 mm	
F37D09.00...31.00RR	76-00740	ø9.00 - ø31.00	Riffelung	0.01 mm	
Standard		Sechskant SK			
F37SK04.00...28.00G	76-00740	4.00 - 28.00	Glatt	1.0 mm	
Lieferbare Varianten		Sechskant SK			
F37SK02.00...28.00G	76-00740	2.00 - 28.00	Glatt	0.01 mm	
Standard		Vierkant VK			
F37VK04.00...23.00G	76-00740	4.00 - 23.00	Glatt	1.0 mm	
Lieferbare Varianten		Vierkant VK			
F37VK04.00...23.00G	76-00740	4.00 - 23.00	Glatt	0.01 mm	
Notfall					
F37ND03.00V	76-53006	Vorbohrung ø3mm			Notfallzange Kopf weich

Für grössere Mengen und für andere Ausführungen kontaktieren Sie bitte unseren Verkauf

Tel: +41 61 935 93 00, verkauf@fabry.ch, www.fabry.ch



Schnabelspannzangen Typ F37



Einheitsnummer -

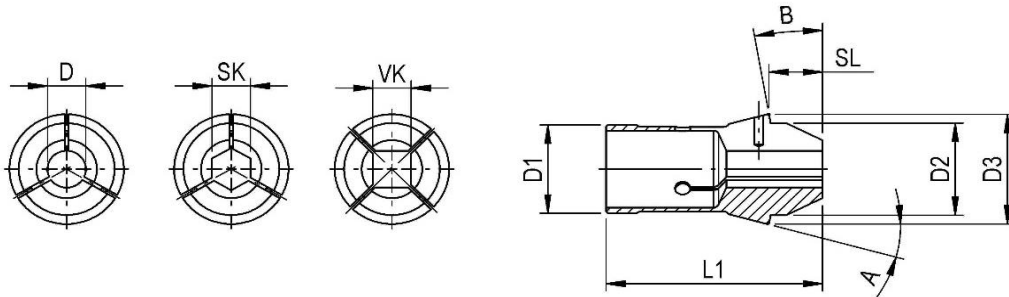

Spezifikation	D1	D2	D3	L1	SL	A	B	
F37SL25	37	40	47	107	25	16	0°	

Fabry Bestell Nr:	Alte-Nr.	Bohrung Form	Bohrung	Stufung	Bemerkungen
Standard		Rund D			
F37SL25D02.00...32.00G	76-02020	ø2.00 - ø32.00	Glatt	1.0 mm	Schnabellänge 25 mm
Lieferbare Varianten		Rund D			
F37SL25D01.97...32.00G	76-02020	ø1.97 - ø32.00	Glatt	0.01 mm	Schnabellänge 25 mm

Für grössere Mengen und für andere Ausführungen kontaktieren Sie bitte unseren Verkauf

Tel: +41 61 935 93 00, verkauf@fabry.ch, www.fabry.ch

Spezifikation
Spannzangen



FABRY AG

SPANNZANGEN-TECHNOLOGIE
CNC-Bearbeitung Drehen Fräsen Schleifen

Spannzangen Typ F38



Einheitsnummer 164 E

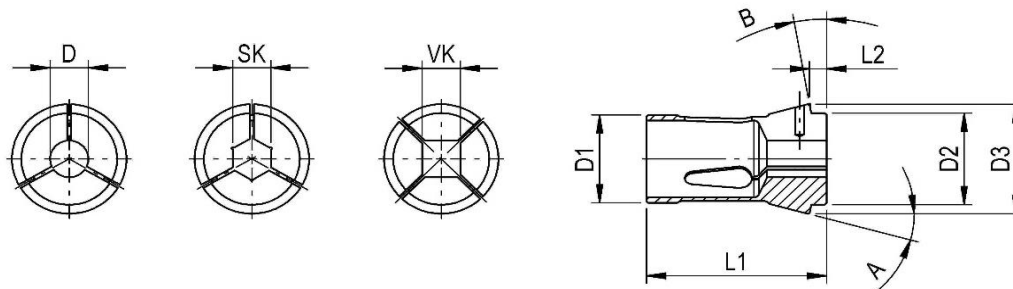

Spezifikation	D1	D2	D3	L1	L2	A	B
F38	38.08	38	49	107.5	9	15°	6°

Fabry Bestell Nr:	Alte-Nr.	Bohrung Form	Bohrung	Stufung	Bemerkungen
Standard		Rund D			
F38D01.00...08.50G	76-00072	ø1.00 - ø8.50	Glatt	0.50 mm	
F38D09.00...33.50R	76-00072	ø9.00 - ø33.50	Rillen	0.50 mm	
Lieferbare Varianten		Rund D			
F38D00.98...32.05G	76-00072	ø0.98 - ø32.05	Glatt	0.01 mm	
F38D09.00...33.55R	76-00072	ø9.00 - ø33.55	Rillen	0.01 mm	
F38D09.00...32.00RR	76-00072	ø9.00 - ø32.00	Riffelung	0.01 mm	
Lieferbare Varianten		Sechskant SK			
F38SK04.00...27.00G	76-00072	4.00 - 27.00	Glatt	0.01 mm	
Lieferbare Varianten		Vierkant VK			
F38VK04.00...22.00G	76-00072	4.00 - 22.00	Glatt	0.01 mm	
Notfall					
F38ND03.00V	76-52270	Vorbohrung ø3mm			Notfallzange Kopf weich

Für grössere Mengen und für andere Ausführungen kontaktieren Sie bitte unseren Verkauf

Tel: +41 61 935 93 00, verkauf@fabry.ch, www.fabry.ch



Schnabelzangen Typ F38



Einheitsnummer -

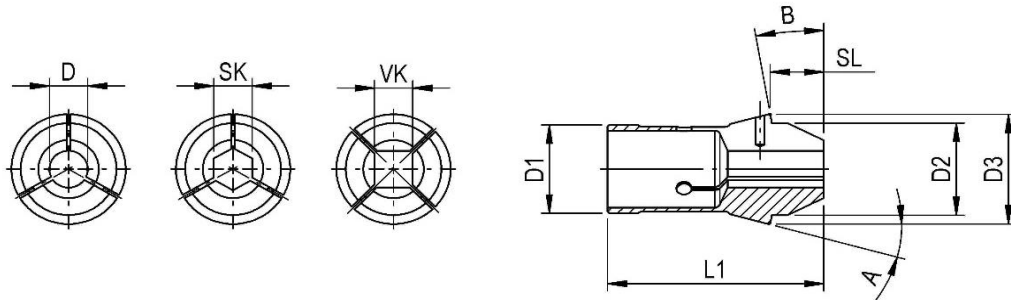

Spezifikation	D1	D2	D3	L1	SL	A	B
F38SL24.5	38.08	38	49	123	24.5	15	6°

Fabry Bestell Nr:	Alte-Nr.	Bohrung Form	Bohrung	Stufung	Bemerkungen
Standard		Rund D			
F38SL24.5D02.00...32.00G	76-02004	ø2.00 - ø32.00	Glatt	1.0 mm	Schnabellänge 24.5 mm
Lieferbare Varianten		Rund D			
F38SL24.5D01.97...32.00G	76-02004	ø1.97 - ø32.00	Glatt	0.01 mm	Schnabellänge 24.5 mm

Für grössere Mengen und für andere Ausführungen kontaktieren Sie bitte unseren Verkauf

Tel: +41 61 935 93 00, verkauf@fabry.ch, www.fabry.ch

Spezifikation
Spannzangen



FABRY AG

SPANNZANGEN-TECHNOLOGIE
CNC-Bearbeitung Drehen Fräsen Schleifen

Spannzangen Typ F42



Einheitsnummer -

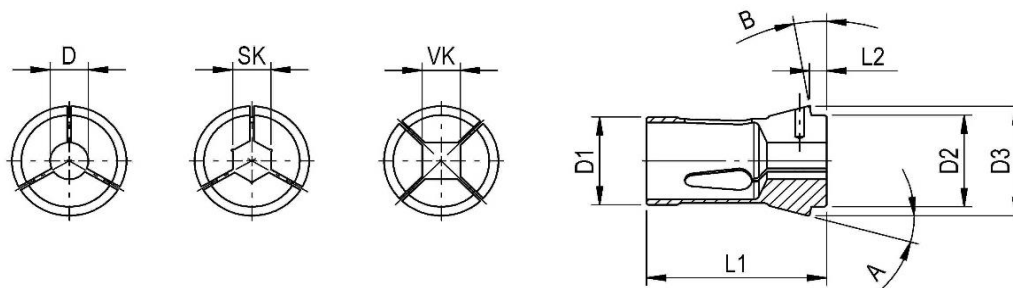

Spezifikation	D1	D2	D3	L1	L2	A	B	
F42	42	42	55	94	9	15°	10°	

Fabry Bestell Nr:	Alte-Nr.	Bohrung Form	Bohrung	Stufung	Bemerkungen
Standard		Rund D			
F42D02.00...08.50G	76-00099	ø2.00 - ø8.50	Glatt	0.50 mm	
F42D09.00...37.00R	76-00099	ø9.00 - ø37.00	Rillen	0.50 mm	
Lieferbare Varianten		Rund D			
F42D00.98...35.80G	76-00099	ø0.98 - ø35.80	Glatt	0.01 mm	
F42D09.00...37.05R	76-00099	ø9.00 - ø37.05	Rillen	0.01 mm	
F42D09.00...35.00RR	76-00099	ø9.00 - ø35.00	Riffelung	0.01 mm	
Lieferbare Varianten		Sechskant SK			
F42SK02.00...31.00G	76-00099	2.00 - 31.00	Glatt	0.01 mm	
Lieferbare Varianten		Vierkant VK			
F42VK04.00...25.00G	76-00099	4.00 - 25.00	Glatt	0.01 mm	
Notfall					
F42ND03.00V		Vorbohrung ø3mm			Notfallzange Kopf weich

Für grössere Mengen und für andere Ausführungen kontaktieren Sie bitte unseren Verkauf

Tel: +41 61 935 93 00, verkauf@fabry.ch, www.fabry.ch



Schnabelspannzangen Typ F42



Einheitsnummer -

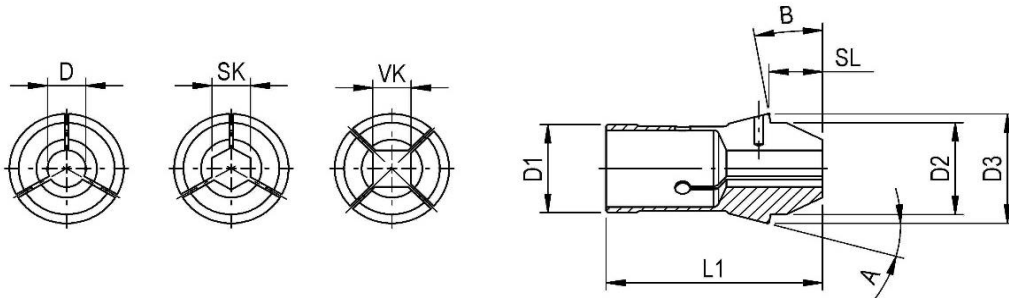

Spezifikation	D1	D2	D3	L1	SL	A	B
F42SL28	42	42	55	113	28	15°	10°

Fabry Bestell Nr:	Bohrung Form	Bohrung	Stufung	Bemerkungen
Standard	Rund D			
F42SL28D02.00...36.00G		ø2.00 - ø36.00	Glatt	1.0 mm Schnabellänge 28 mm
Lieferbare Varianten	Rund D			
F42SL28D01.97...38.00G		ø1.97 - ø38.00	Glatt	0.01 mm Schnabellänge 28 mm

Für grössere Mengen und für andere Ausführungen kontaktieren Sie bitte unseren Verkauf

Tel: +41 61 935 93 00, verkauf@fabry.ch, www.fabry.ch

Spezifikation
Spannzangen



FABRY AG

SPANNZANGEN-TECHNOLOGIE
CNC-Bearbeitung Drehen Fräsen Schleifen

Spannzangen Typ F48



Einheitsnummer 173 E

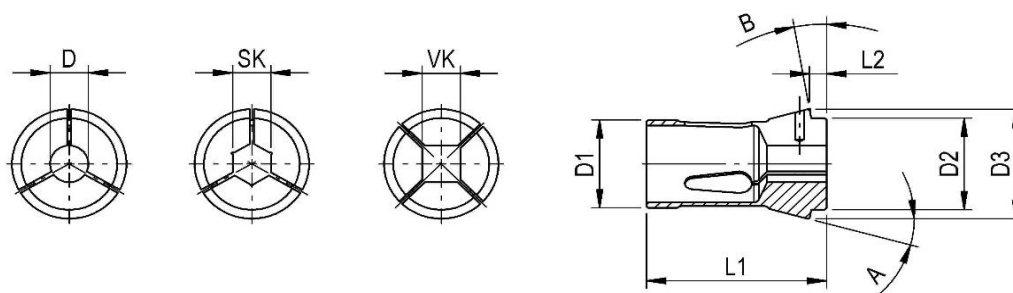

Spezifikation	D1	D2	D3	L1	L2	A	B
F48	48	50	60	94	9	15°	10°

Fabry Bestell Nr:	Alte-Nr.	Bohrung Form	Bohrung	Stufung	Bemerkungen
Standard		Rund D			
F48D01.00...44.00G	76-00081	ø1.00 - ø44.00	Glatt	0.50 mm	
F48D09.00...44.00R	76-00081	ø9.00 - ø44.00	Rillen	0.50 mm	
Lieferbare Varianten		Rund D			
F48D00.98...44.05G	76-00081	ø0.98 - ø44.05	Glatt	0.01 mm	
F48D09.00...44.05R	76-00081	ø9.00 - ø44.05	Rillen	0.01 mm	
F48D09.00...43.00RR	76-00081	ø9.00 - ø43.00	Riffelung	0.01 mm	
Standard		Sechskant SK			
F48SK04.00...36.00G	76-00081	4.00 - 36.00	Glatt	1.0 mm	
Lieferbare Varianten		Sechskant SK			
F48SK02.00...38.00G	76-00081	2.00 - 38.00	Glatt	0.01 mm	
Standard		Vierkant VK			
F48VK04.00...30.00G	76-00081	4.00 - 30.00	Glatt	1.0 mm	
Lieferbare Varianten		Vierkant VK			
F48VK04.00...30.00G	76-00081	4.00 - 30.00	Glatt	0.01 mm	
Notfall					
F48ND03.00V	76-52579	Vorbohrung ø3mm			Notfallzange Kopf weich

Für grössere Mengen und für andere Ausführungen kontaktieren Sie bitte unseren Verkauf

Tel: +41 61 935 93 00, verkauf@fabry.ch, www.fabry.ch



Schnabelspannzangen Typ F48

Einheitsnummer -

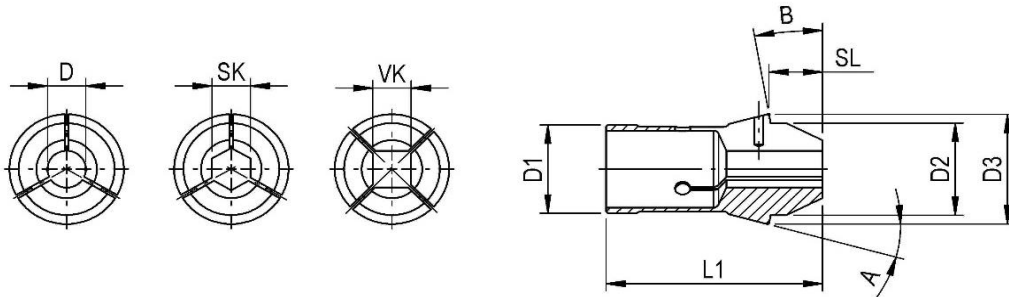

Spezifikation	D1	D2	D3	L1	SL	A	B
F48SL28	48	50	60	113	28	15°	10°

Fabry Bestell Nr:	Alte-Nr.	Bohrung Form	Bohrung	Stufung	Bemerkungen
Standard		Rund D			
F48SL28D02.00...42.00G	76-02006	ø2.00 - ø42.00	Glatt	1.0 mm	Schnabellänge 28 mm
Lieferbare Varianten		Rund D			
F48SL28D01.97...42.50G	76-02006	ø1.97 - ø42.50	Glatt	0.01 mm	Schnabellänge 28 mm

Für grössere Mengen und für andere Ausführungen kontaktieren Sie bitte unseren Verkauf

Tel: +41 61 935 93 00, verkauf@fabry.ch, www.fabry.ch

Spezifikation
Spannzangen



FABRY AG

SPANNZANGEN-TECHNOLOGIE
CNC-Bearbeitung Drehen Fräsen Schleifen

Spannzangen Typ FS48 Für Fabry Schnellspannsystem



Einheitsnummer -

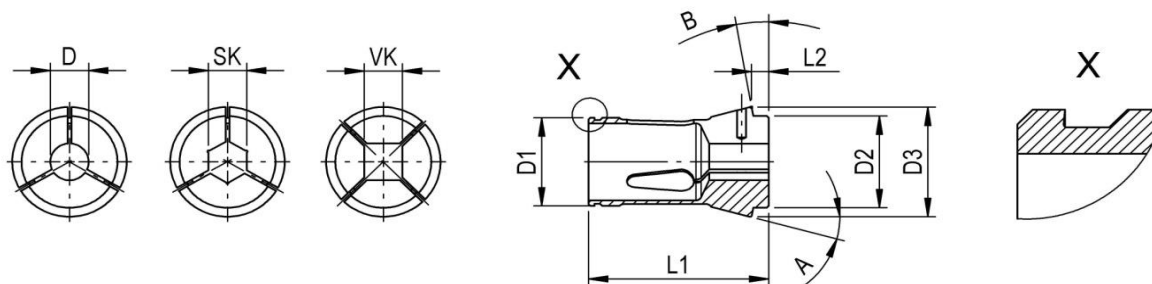

Spezifikation	D1	D2	D3	L1	L2	A	B	
FS48	48	50	60	94	9	15°	10°	

Fabry Bestell Nr:	Alte-Nr.	Bohrung Form	Bohrung	Stufung	Bemerkungen
Standard		Rund D			
FS48D02.00...42.00G	76-00081	ø2.00 - ø42.00	Glatt	0.50 mm	
FS48D09.00...42.00R	76-00081	ø9.00 - ø42.00	Rillen	0.50 mm	
Lieferbare Varianten		Rund D			
FS48D00.98...44.05G	76-00081	ø0.98 - ø44.05	Glatt	0.01 mm	
FS48D09.00...44.05R	76-00081	ø9.00 - ø44.05	Rillen	0.01 mm	
FS48D09.00...43.00RR	76-00081	ø9.00 - ø43.00	Riffelung	0.01 mm	
Standard		Sechskant SK			
FS48SK04.00...36.00G	76-00081	4.00 - 36.00	Glatt	1.0 mm	
Lieferbare Varianten		Sechskant SK			
FS48SK02.00...38.00G	76-00081	2.00 - 38.00	Glatt	0.01 mm	
Standard		Vierkant VK			
FS48VK04.00...30.00G	76-00081	4.00 - 30.00	Glatt	1.0 mm	
Lieferbare Varianten		Vierkant VK			
FS48VK04.00...30.00G	76-00081	4.00 - 30.00	Glatt	0.01 mm	
Notfall					
FS48ND03.00V	76-52579	Vorbohrung ø3mm			Notfallzange Kopf weich

Für grössere Mengen und für andere Ausführungen kontaktieren Sie bitte unseren Verkauf

Tel: +41 61 935 93 00, verkauf@fabry.ch, www.fabry.ch

Spezifikation
Spannzangen



FABRY AG

SPANNZANGEN-TECHNOLOGIE
CNC-Bearbeitung Drehen Fräsen Schleifen

Spannzangen Typ F58



Einheitsnummer 177 E

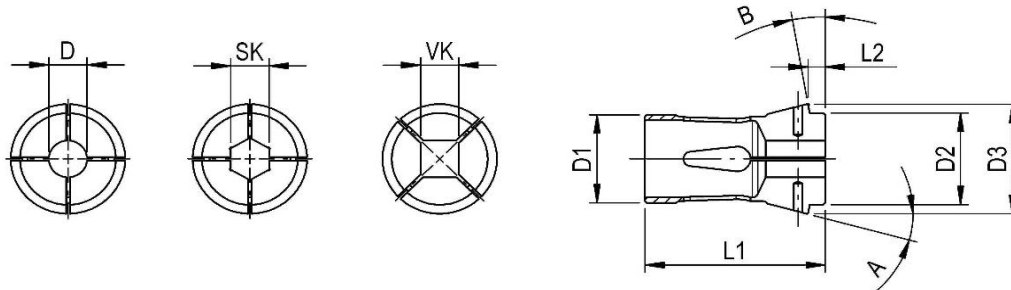

Spezifikation	D1	D2	D3	L1	L2	A	B	
F58	58	60	70	94	9	15°	10°	

Fabry Bestell Nr:	Alte-Nr.	Bohrung Form	Bohrung	Stufung	Bemerkungen
Standard		Rund D			
F58D04.00...08.00G	76-00355	ø04.00 - ø08.00	Glatt	1.0 mm	
F58D09.00...52.00R	76-00355	ø09.00 - ø52.00	Rillen	1.0 mm	
Lieferbare Varianten		Rund D			
F58D03.95...52.05G	76-00355	ø03.95 - ø52.05	Glatt	0.01 mm	
F58D09.00...52.05R	76-00355	ø09.00 - ø52.05	Rillen	0.01 mm	
F58D09.00...51.00RR	76-00355	ø09.00 - ø51.00	Riffelung	0.01 mm	
Lieferbare Varianten		Sechskant SK			
F58SK04.00...44.00G	76-00355	04.00 - 44.00	Glatt	0.01 mm	
Lieferbare Varianten		Vierkant VK			
F58VK17.00...36.00G	76-00355	17.00 - 36.00	Glatt	0.01 mm	

Für grössere Mengen und für andere Ausführungen kontaktieren Sie bitte unseren Verkauf

Tel: +41 61 935 93 00, verkauf@fabry.ch, www.fabry.ch



Schnabelzangen Typ F58



Einheitsnummer -

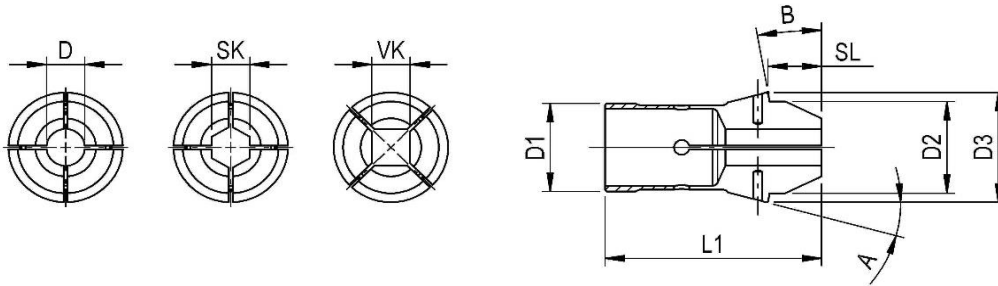

Spezifikation	D1	D2	D3	L1	SL	A	B
F58SL29	58	60	70	114	29	15°	10°

Fabry Bestell Nr:	Bohrung Form	Bohrung	Stufung	Bemerkungen
Standard	Rund D			
F58SL29D06.00...30.00G	∅06.00 - ∅30.00	Glatt	1.0 mm	
Lieferbare Varianten	Rund D			
F58SL29D06.00...30.50G	∅06.00 - ∅30.50	Glatt	0.01 mm	

Für grössere Mengen und für andere Ausführungen kontaktieren Sie bitte unseren Verkauf

Tel: +41 61 935 93 00, verkauf@fabry.ch, www.fabry.ch

Spezifikation
Spannzangen



FABRY AG

SPANNZANGEN-TECHNOLOGIE
CNC-Bearbeitung Drehen Fräsen Schleifen

Spannzangen Typ F66



Einheitsnummer -

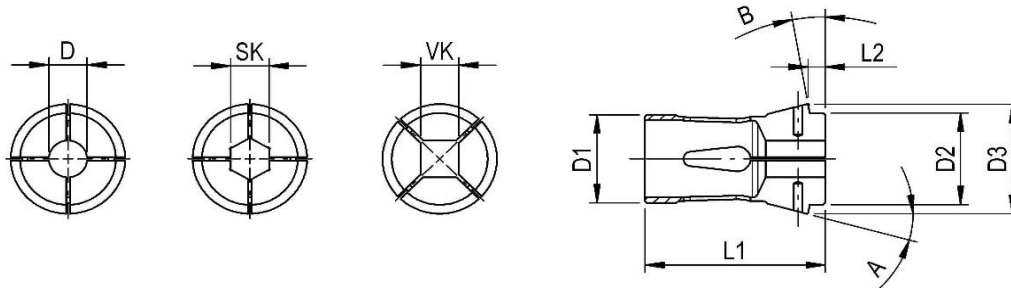

Spezifikation	D1	D2	D3	L1	L2	A	B	
F66	66	73	84	110	9	15°	10°	

Fabry Bestell Nr:	Alte-Nr.	Bohrung Form	Bohrung	Stufung	Bemerkungen
Standard		Rund D			
F66D02.00...60.00G	76-00359	ø2.00 - ø60.00	Glatt	0.50 mm	
F66D09.00...60.00R	76-00359	ø9.00 - ø60.00	Rillen	0.50 mm	
Lieferbare Varianten		Rund D			
F66D02.01...60.49G	76-00359	ø2.01 - ø60.49	Glatt	0.01 mm	ab ø 60.20 nicht durchgehend
F66D09.00...61.00R	76-00359	ø9.00 - ø61.00	Rillen	0.01 mm	ab ø 60.20 nicht durchgehend
F66D09.00...59.00RR	76-00359	ø9.00 - ø59.00	Riffelung	0.01 mm	
Standard		Sechskant SK			
F66SK07.00...52.00G	76-00359	7.00 - 52.00	Glatt	1.0 mm	
Lieferbare Varianten		Sechskant SK			
F66SK04.00...52.00G	76-00359	4.00 - 52.00	Glatt	0.01 mm	
Standard		Vierkant VK			
F66VK07.00...42.00G	76-00359	7.00 - 42.00	Glatt	1.0 mm	
Lieferbare Varianten		Vierkant VK			
F66VK04.00...42.00G	76-00359	4.00 - 42.00	Glatt	0.01 mm	
Notfall					
F66ND05.00V	76-53000	Vorbohrung ø5mm			Notfallzange Kopf weich

Für grössere Mengen und für andere Ausführungen kontaktieren Sie bitte unseren Verkauf

Tel: +41 61 935 93 00, verkauf@fabry.ch, www.fabry.ch



Schnabelspannzangen Typ F66



Einheitsnummer -

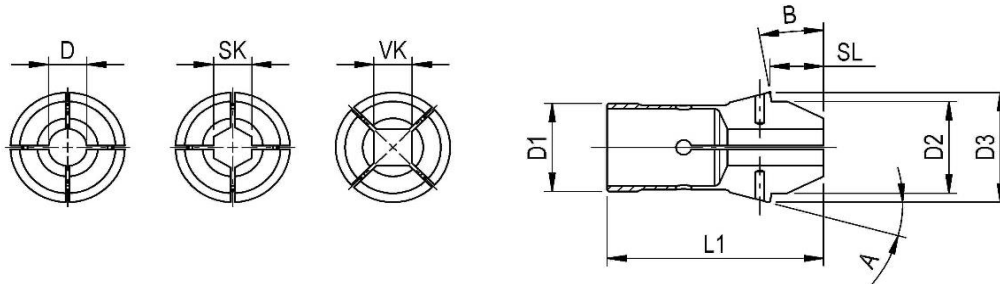

Spezifikation	D1	D2	D3	L1	SL	A	B	
F66SL39	66	73	84	140	39	15°	10°	

Fabry Bestell Nr:	Bohrung Form	Bohrung	Stufung	Bemerkungen
Standard	Rund D			
F66SL39D04.00...59.00G	ø4.00 - ø59.00	Glatt	1.0 mm	Schnabellänge 39 mm
Lieferbare Varianten	Rund D			
F66SL39D03.95...59.50G	ø3.95 - ø59.50	Glatt	0.01 mm	Schnabellänge 39 mm

Für grössere Mengen und für andere Ausführungen kontaktieren Sie bitte unseren Verkauf

Tel: +41 61 935 93 00, verkauf@fabry.ch, www.fabry.ch

Spezifikation
Spannzangen



FABRY AG

SPANNZANGEN-TECHNOLOGIE
CNC-Bearbeitung Drehen Fräsen Schleifen

Spannzangen Typ F80



Einheitsnummer -

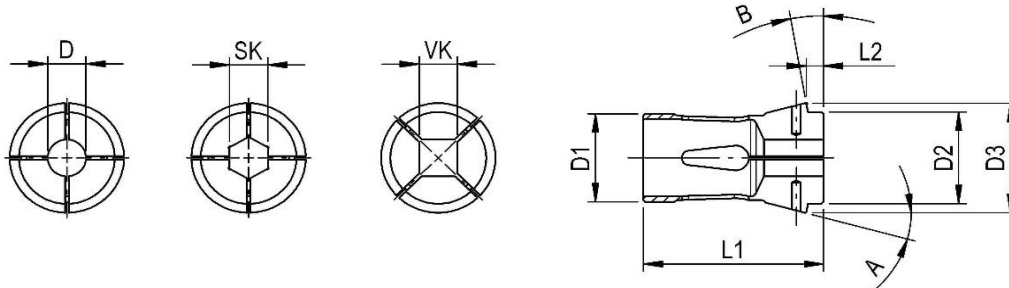

Spezifikation	D1	D2	D3	L1	L2	A	B	
F80	80	85	98	115	9	15°	10°	

Fabry Bestell Nr:	Alte-Nr.	Bohrung Form	Bohrung	Stufung	Bemerkungen
Standard		Rund D			
F80D08.00...70.00R		ø08.00 - ø70.00	Rillen	1.0 mm	
Lieferbare Varianten		Rund D			
F80D08.00...70.00R		ø08.00 - ø70.00	Rillen	0.01 mm	
F80D08.00...70.00RR		ø08.00 - ø70.00	Riffelung	0.01 mm	
Lieferbare Varianten		Sechskant SK			
F80SK07.00...60.00G	76-00359	07.00 - 60.00	Glatt	0.01 mm	
Lieferbare Varianten		Vierkant VK			
F80VK06.00...49.00G	76-00359	06.00 - 49.00	Glatt	0.01 mm	

Für grössere Mengen und für andere Ausführungen kontaktieren Sie bitte unseren Verkauf

Tel: +41 61 935 93 00, verkauf@fabry.ch, www.fabry.ch



Spannzangen Typ B6



Einheitsnummer -

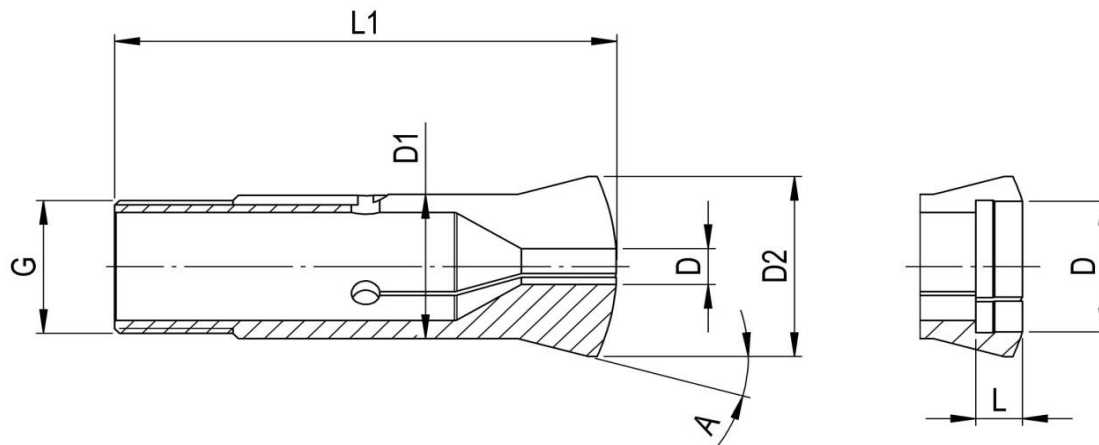

Abmessungen	D1	D2	L1	A	G
B6	6	10.5	31.3	20°	ø5 x 0.706 - 55°

Fabry Bestell Nr:	Alte-Nr.	Bohrung Form	L	Stufung	Bemerkungen
Standard		Rund D			
B6D...	72-00128	ø 00.30...03.00	-	0.1 mm	
		ø 03.50...04.50	12	0.5 mm	
		ø 05.00	4.5	0.5 mm	
Lieferbare Varianten		Rund D			
B6D...	72-00128	ø 00.70...05.00		0.01 mm	

Für grössere Mengen und für andere Ausführungen kontaktieren Sie bitte unseren Verkauf
Tel: +41 61 935 93 00, verkauf@fabry.ch, www.fabry.ch



Restposten Spannzangen Typ B6 - B32



Einheitsnummer -

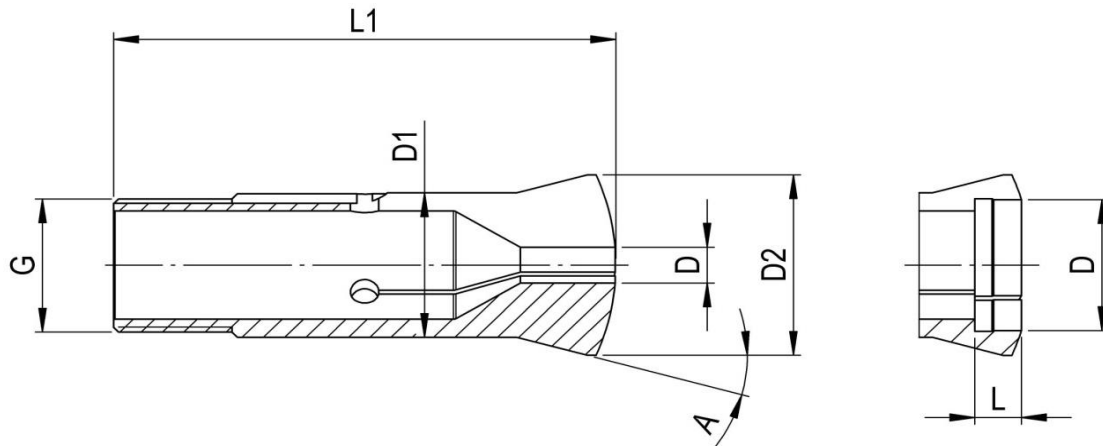

Abmessungen	D1	D2	L1	A	G
B6 (72-01897)	6	9	31.3	20°	5 x 36f / 55°
B23(72-00142)	23	32	88	20°	M 21 x 1
B32(72-00055)	32	40	102	15°	M 30 x 1.5

Fabry Bestell Nr:	Alte-Nr.	Bohrung Form	L	Stufung	Bemerkungen
B6 (72-01897)	72-01897	ø07.00 - ø05.50	Rund	0.1 mm	Restposten
B23(72-00142)	72-00142	ø03.50 - ø22.00	Rund	0.50 mm	Restposten
B32(72-00055)	72-00055	ø01.00 - ø30.00	Rund UP	0.50 mm	Restposten

Für grössere Mengen und für andere Ausführungen kontaktieren Sie bitte unseren Verkauf
Tel: +41 61 935 93 00, verkauf@fabry.ch, www.fabry.ch



Spannzangen Typ B8



Einheitsnummer 302E

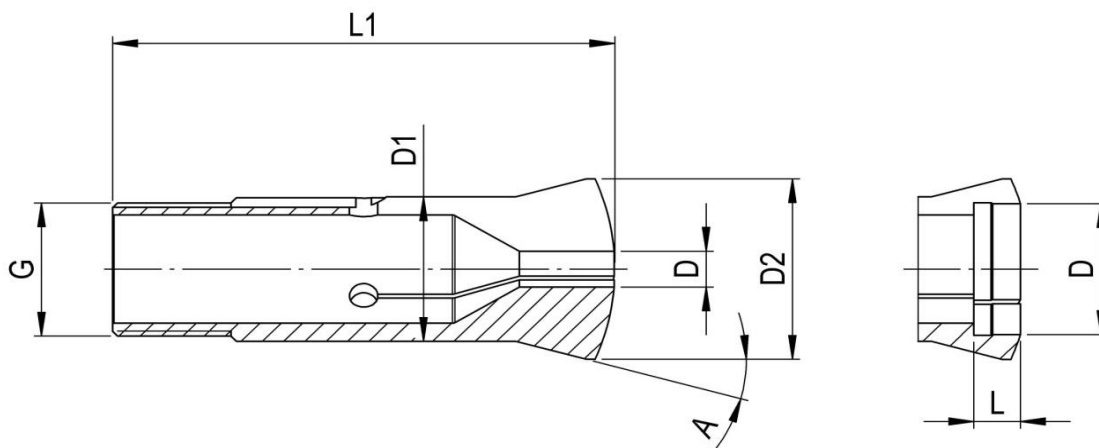

Abmessungen	D1	D2	L1	A	G
B8	8	13	35.5	20°	ø6.82 x 0.625 - 55°

Fabry Bestell Nr:	Alte-Nr.	Bohrung Form	L	Stufung	Bemerkungen
Standard		Rund D			
B8D...	72-00137	ø 00.30...03.00	-	0.1 mm	
		ø 03.00...04.00	-	0.5 mm	
		ø 04.50...06.50	13	0.5 mm	
		ø 06.50...07.00	6	0.5 mm	
		ø 07.50	5	0.5 mm	
		ø 08.00	4	0.5 mm	
Lieferbare Varianten		Rund D			
B8D...	72-00137	ø 00.70...08.00		0.01 mm	

Für grössere Mengen und für andere Ausführungen kontaktieren Sie bitte unseren Verkauf
Tel: +41 61 935 93 00, verkauf@fabry.ch, www.fabry.ch



Schnabelspannzangen Typ B8SL7



Einheitsnummer -

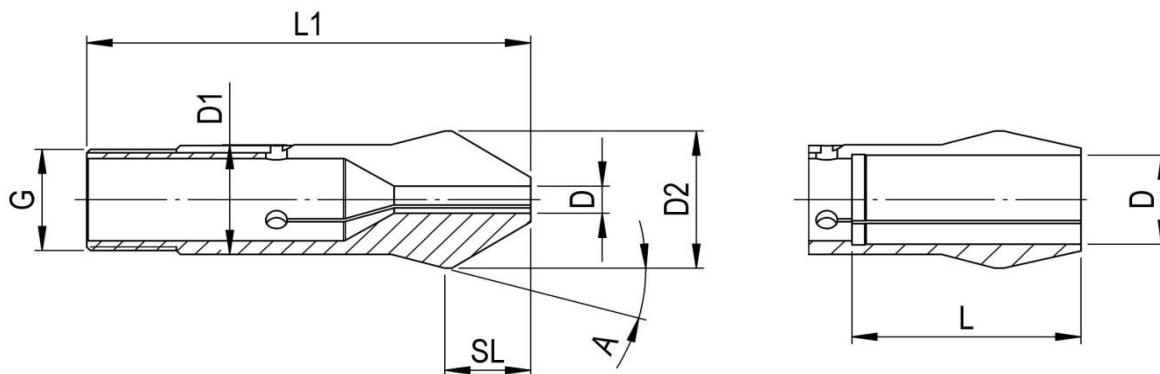

Abmessungen	D1	D2	L1	SL	A	G
B8SL7	8	13	40.5	7	20°	ø6.82 x 0.625 - 55°

Fabry Bestell Nr:	Alte-Nr.	Bohrung Form	L	Stufung	Bemerkungen
Standard		Rund D			
B8SL7D...	72-00095	ø 00.50...03.00	-	0.5 mm	
		ø 04.00...06.00	21	1.0 mm	
Lieferbare Varianten		Rund D			
B8SL7D...	72-00095	ø 00.70...06.00		0.01 mm	

Für grössere Mengen und für andere Ausführungen kontaktieren Sie bitte unseren Verkauf
Tel: +41 61 935 93 00, verkauf@fabry.ch, www.fabry.ch



Spannzangen Typ B15



Einheitsnummer 324E

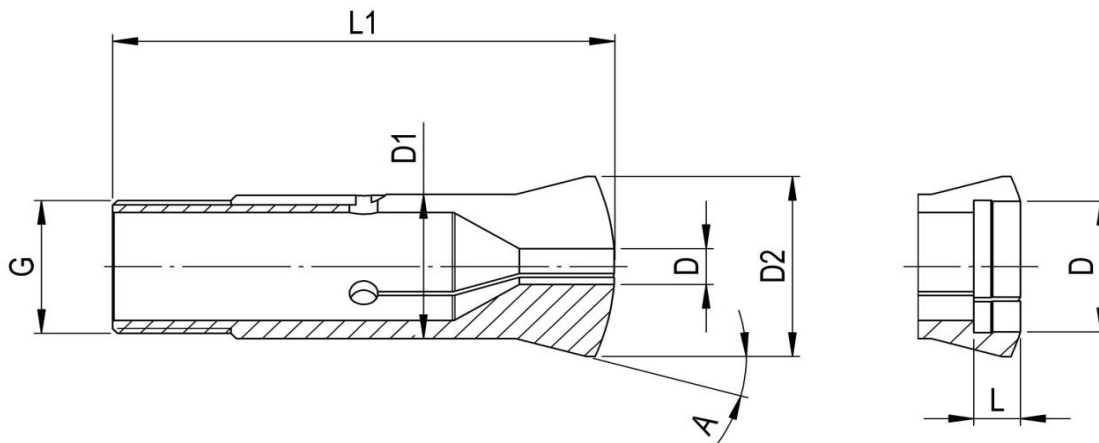

Abmessungen	D1	D2	L1	A	G
B15	15	21	55	20°	M13 x 1

Fabry Bestell Nr:	Alte-Nr.	Bohrung Form	L	Stufung	Bemerkungen
Standard		Rund D			
B15D...	72-00139	ø 01.00...09.50	-	0.5 mm	
		ø 10.00...12.00	20	1.0 mm	
		ø 13.00	8.5	1.0 mm	
		ø 14.00	7	1.0 mm	
		ø 15.00	6	1.0 mm	
Lieferbare Varianten		Rund D			
B15D...	72-00139	ø 01.00...15.00		0.01 mm	

Für grössere Mengen und für andere Ausführungen kontaktieren Sie bitte unseren Verkauf
 Tel: +41 61 935 93 00, verkauf@fabry.ch, www.fabry.ch

Spezifikation
Spannzangen



FABRY AG
SPANNZANGEN-TECHNOLOGIE
CNC-Bearbeitung Drehen Fräsen Schleifen

Spannzangen Typ B32



Einheitsnummer 3713E

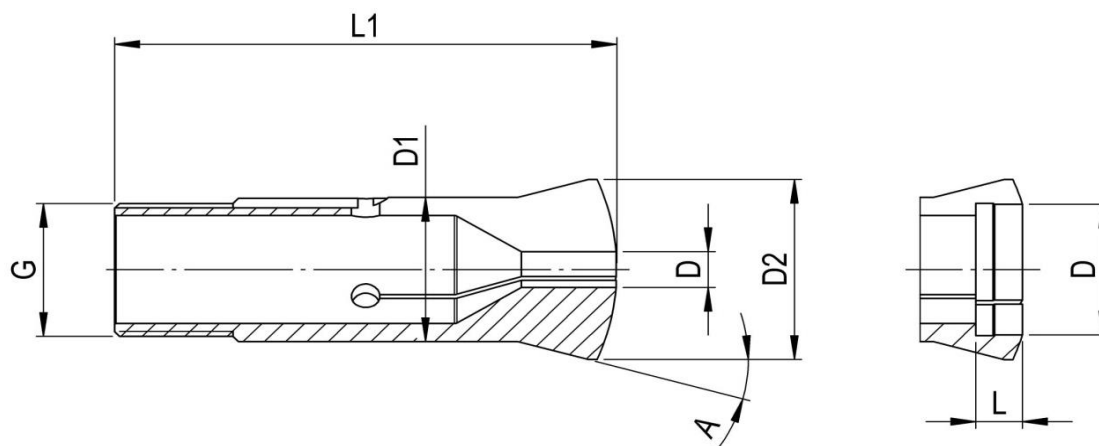

Abmessungen	D1	D2	L1	A	G
B32	32	40	106	15°	ø29.7 x 1.693 - 45°/5°

Fabry Bestell Nr:	Alte-Nr.	Bohrung Form	L	Stufung	Bemerkungen
Standard		Rund D			
B32D...	72-00065	ø 01.00...24.00	-	0.5 mm	
		ø 24.50...28.00	44	0.5 mm	
		ø 28.50...30.00	12	0.5 mm	
		ø 30.50...32.00	8	0.5 mm	
Lieferbare Varianten		Rund D			
B32D...	72-00065	ø 01.00...32.00		0.01 mm	
Standard		Sechskant SK			
B32SK...	72-00065	ø 04.00...20.00	-	1.0 mm	
Lieferbare Varianten		Sechskant SK			
B32SK...	72-00065	ø 04.00...20.00		0.01 mm	
Standard		Vierkant VK			
B32VK...	72-00065	ø 04.00...17.00	-	1.0 mm	
Lieferbare Varianten		Vierkant VK			
B32VK...	72-00065	ø 04.00...17.00		0.01 mm	

Für grössere Mengen und für andere Ausführungen kontaktieren Sie bitte unseren Verkauf
Tel: +41 61 935 93 00, verkauf@fabry.ch, www.fabry.ch



Schnabelspannzangen Typ B32SL24



Einheitsnummer -

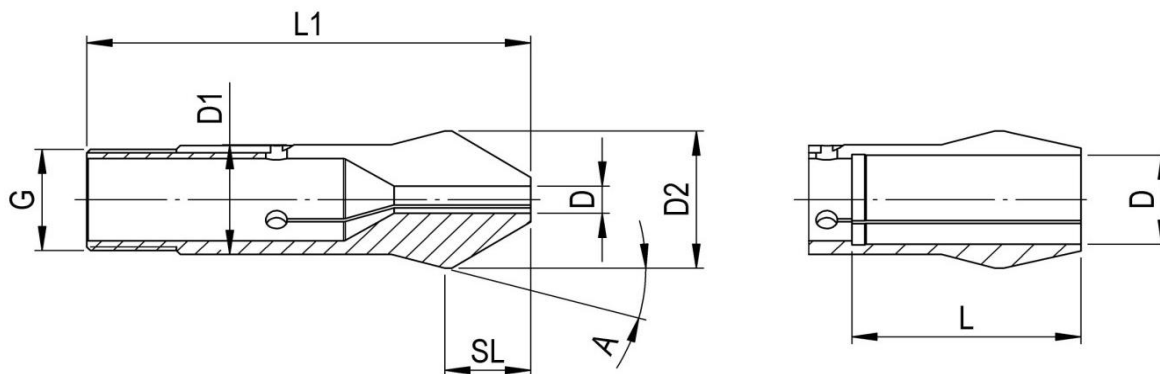

Abmessungen	D1	D2	L1	SL	A	G
B32SL24	32	40	124	24	15°	ø29.7 x 1.693 - 45°/5°

Fabry Bestell Nr:	Alte-Nr.	Bohrung Form	L	Stufung	Bemerkungen
Standard		Rund D			
B32SL24D...	72-02003	ø 03.00...24.00	-	1.0 mm	
		ø 25.00	64	1.0 mm	
Lieferbare Varianten		Rund D			
B32SL24D...	72-02003	ø 03.00...25.00		0.01 mm	

Für grössere Mengen und für andere Ausführungen kontaktieren Sie bitte unseren Verkauf
Tel: +41 61 935 93 00, verkauf@fabry.ch, www.fabry.ch



Restposten Spannzangen Typ BM32



Einheitsnummer -

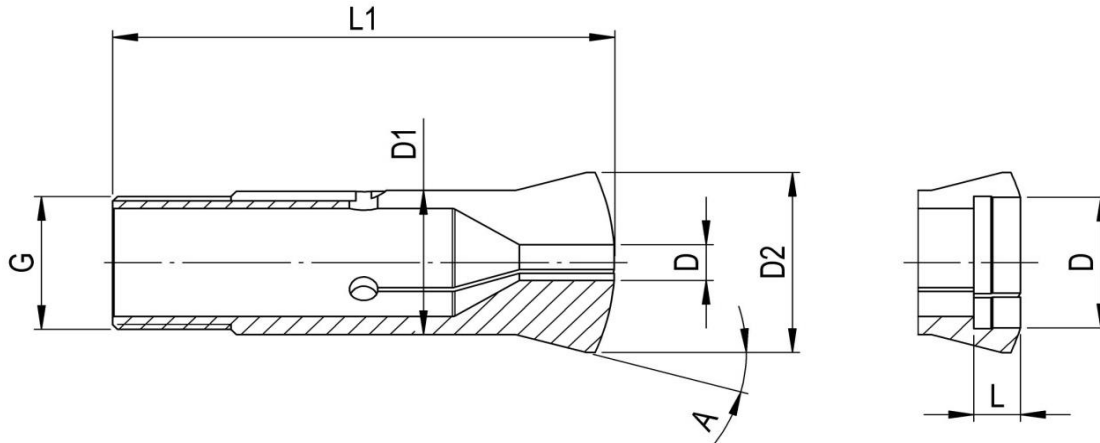

Abmessungen	D1	D2	L1	A	G
BM32	32	40	102	15°	M30 x 1.5

Fabry Bestell Nr:	Alte-Nr.	Bohrung Form	L	Stufung	Bemerkungen
Standard		Rund D			
BM32D...UP	72-00055	∅ 01.00...24.00	-	0.5 mm	
		∅ 24.50...28.00	44	0.5 mm	
		∅ 28.50...30.00	12	0.5 mm	
		∅ 30.50...32.00	8	0.5 mm	
Lieferbare Varianten		Rund D			
BM32D...UP	72-00055	∅ 01.00...32.00		0.01 mm	

Für grössere Mengen und für andere Ausführungen kontaktieren Sie bitte unseren Verkauf
Tel: +41 61 935 93 00, verkauf@fabry.ch, www.fabry.ch

Spezifikation
Spannzangen



FABRY AG
 SPANNZANGEN-TECHNOLOGIE
 CNC-Bearbeitung Drehen Fräsen Schleifen

Schnabelspannzangen Typ B32/45SL32.5

FAB

Einheitsnummer -

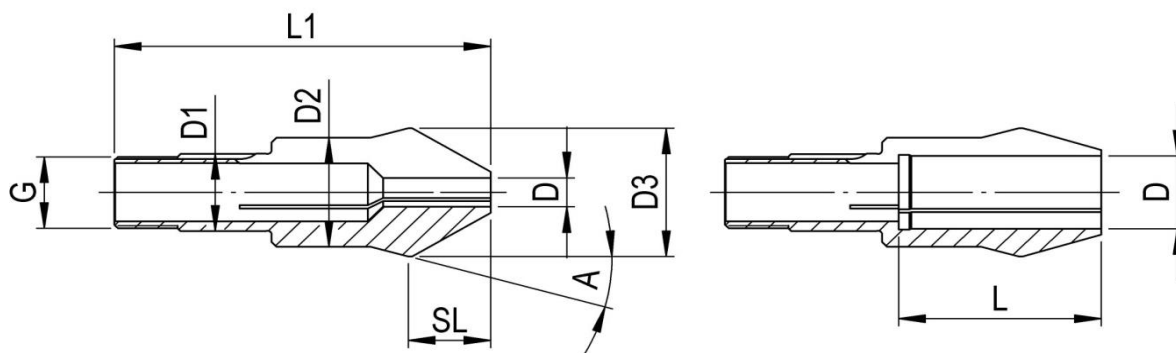

Abmessungen	D1	D2	D3	L1	SL	A	G
B32/45SL32.5	32	45	53	148.5	32.5	15°	ø29.7 x 1.693 - 45°/5°

Fabry Bestell Nr:	Alte-Nr.	Bohrung Form	L	Stufung	Bemerkungen
Standard		Rund D			
B32/45SL32.5D...UP	72-02005	ø 02.00...24.00	-	0.5 mm	
		ø 24.05...40.00	80	0.5 mm	
Lieferbare Varianten		Rund D			
B32/45SL32.5D...UP	72-02005	ø 02.00...40.00		0.01 mm	

Für grössere Mengen und für andere Ausführungen kontaktieren Sie bitte unseren Verkauf
 Tel: +41 61 935 93 00, verkauf@fabry.ch, www.fabry.ch



Spannzangen Typ B45



Einheitsnummer -

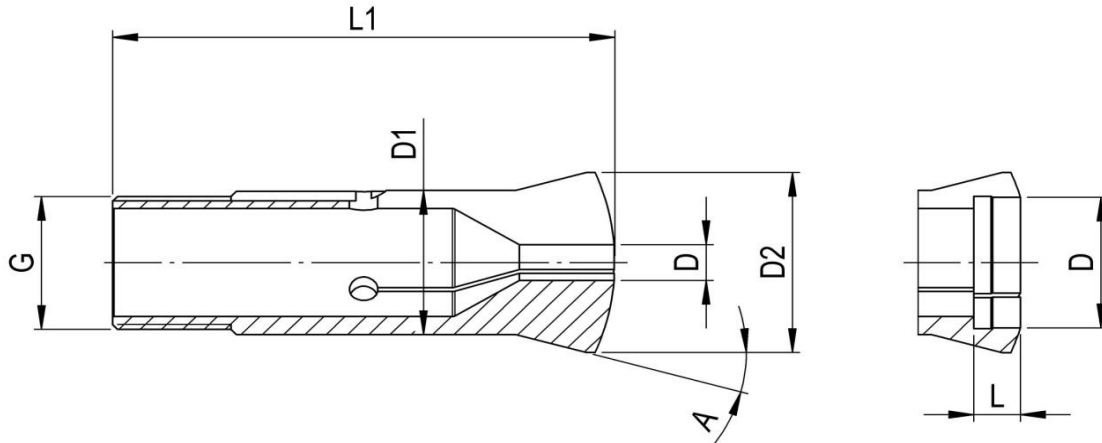

Abmessungen	D1	D2	L1	A	G
B45	45	53	115	15°	M42 x 1.5

Fabry Bestell Nr:	Alte-Nr.	Bohrung Form	L	Stufung	Bemerkungen
Standard		Rund D			
B45D...	72-00199	ø 01.00...36.00	-	1.0 mm	
		ø 37.00...40.00	53	1.0 mm	
		ø 41.00	14	1.0 mm	
		ø 42.00	12	1.0 mm	
		ø 43.00	10	1.0 mm	
		ø 44.00	8	1.0 mm	
Lieferbare Varianten		Rund D			
B45D...	72-00199	ø 01.00...44.00		0.01 mm	

Für grössere Mengen und für andere Ausführungen kontaktieren Sie bitte unseren Verkauf
Tel: +41 61 935 93 00, verkauf@fabry.ch, www.fabry.ch

Spezifikation
Spannzangen



FABRY AG
SPANNZANGEN-TECHNOLOGIE
CNC-Bearbeitung Drehen Fräsen Schleifen

Spannzangen Typ L20K28

FAB

Einheitsnummer 355E

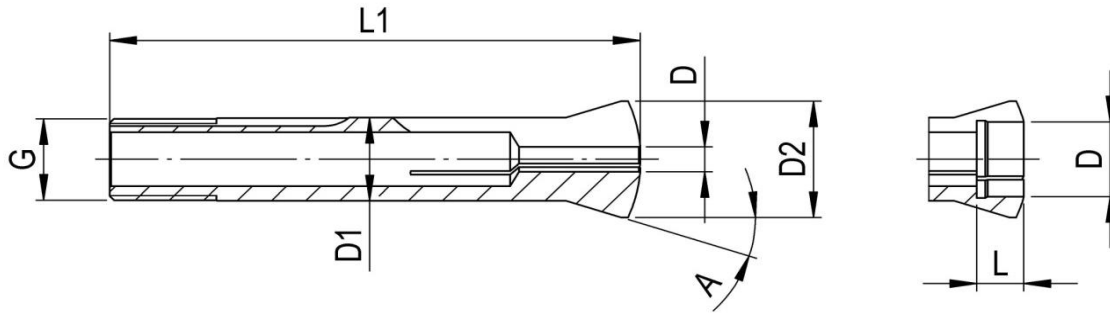

Abmessungen	D1	D2	L1	A	G1
L20K28	ø20	ø28	122	17°30'	ø19.7 x 2.0 - 45°/5°

Fabry Bestell Nr:	Alte-Nr.	Bohrung Form	L	Stufung	Bemerkungen
Standard		Rund D			
L20K28D...	77-00122	ø 01.00...05.00	-	0.5 mm	
		ø 06.00...13.00	-	1.0 mm	
		ø 14.00...17.00	59	1.0 mm	
		ø 18.00	12	1.0 mm	
		ø 19.00	10	1.0 mm	
		ø 20.00	8	1.0 mm	
		ø 21.00	6.5	1.0 mm	
		ø 22.00	4.5	1.0 mm	
Lieferbare Varianten		Rund D			
L20K28D...	77-00122	ø 01.00...22.00		0.01 mm	

Für grössere Mengen und für andere Ausführungen kontaktieren Sie bitte unseren Verkauf
Tel: +41 61 935 93 00, verkauf@fabry.ch, www.fabry.ch

Spezifikation
Spannzangen



FABRY AG

SPANNZANGEN-TECHNOLOGIE
CNC-Bearbeitung Drehen Fräsen Schleifen

Restposten Spannzangen Typ L20K27.5



Einheitsnummer -

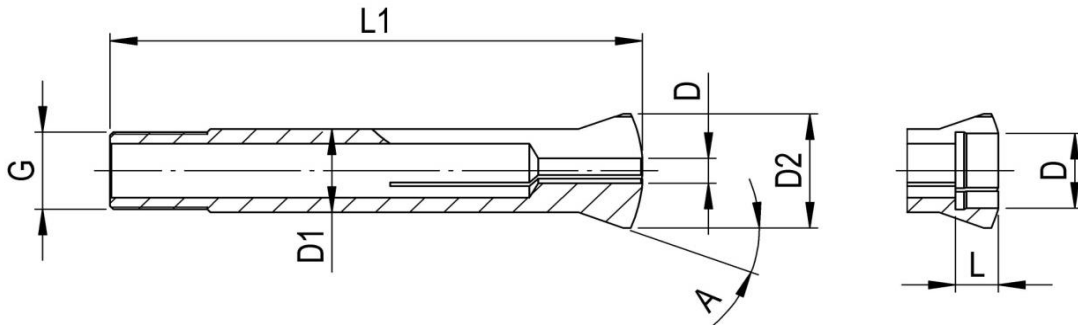

Abmessungen	D1	D2	L1	A	G1
L20K27.5	ø20	ø27.5	122	20°	ø18.5 x 1.4 - 50°

Fabry Bestell Nr:	Alte-Nr.	Bohrung Form	L	Stufung	Bemerkungen
Standard		Rund D			
L20K27.5D...	77-00826	ø 02.00...13.00	-	0.5 mm	Restposten
		ø 13.50...18.00	59	0.5 mm	Restposten
		ø 18.50	11	0.5 mm	Restposten
		ø 19.00	10	0.5 mm	Restposten
		ø 19.50	9	0.5 mm	Restposten
		ø 20.00	8	0.5 mm	Restposten
Lieferbare Varianten		Rund D			
L20K27.5D...	77-00826	ø 02.00...20.00		0.01 mm	

Für grössere Mengen und für andere Ausführungen kontaktieren Sie bitte unseren Verkauf
Tel: +41 61 935 93 00, verkauf@fabry.ch, www.fabry.ch

Spezifikation
Spannzangen



FABRY AG
SPANNZANGEN-TECHNOLOGIE
CNC-Bearbeitung Drehen Fräsen Schleifen

Restposten Spannzangen Typ P3 - P16



Einheitsnummer -

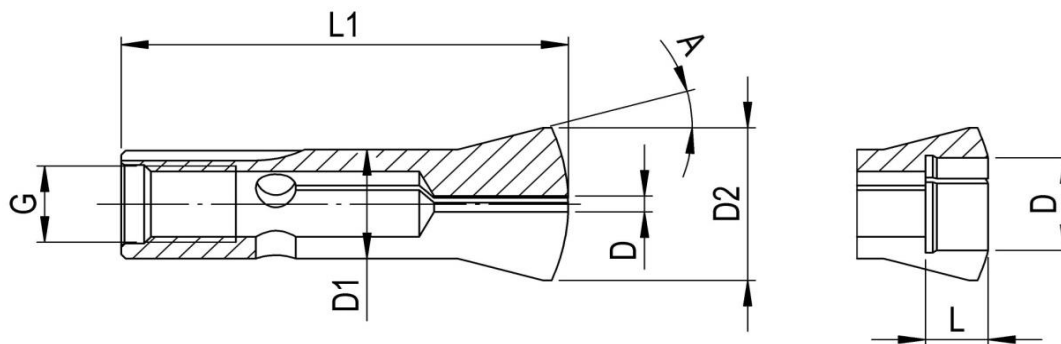

Abmessungen	D1	D2	L1	A	G	
P3	ø3	ø4.5	19	15°	M2.5x04	
P4	ø4	ø6	15.8	20°	M2.5x04	
P4.5	ø4.5	ø6.75	22.5	15°	M3	
P16	ø16	ø22	75	15°	M8	

Fabry Bestell Nr:	Alte-Nr.	Bohrung Form	L	Stufung	Bemerkungen
Standard		Rund D			
P3D...	78-00218	ø 02.10...02.50	-	0.1 mm	Restposten
P4D...	78-00152	ø 01.00...03.00	-	0.1 mm	Restposten
P4.5D...	78-00158	ø 00.50...01.60	-	0.1 mm	Restposten
P16D...	78-00392	ø 01.00...06.40	-	0.1 mm	Restposten
P16D...	78-00392	ø 06.50...12.00	45	0.1 mm	Restposten

Für grössere Mengen und für andere Ausführungen kontaktieren Sie bitte unseren Verkauf
Tel: +41 61 935 93 00, verkauf@fabry.ch, www.fabry.ch

**Spezifikation
Spannzangen**



FABRY AG

SPANNZANGEN-TECHNOLOGIE
CNC-Bearbeitung Drehen Fräsen Schleifen

Spannzangen Typ P4.5



Einheitsnummer -

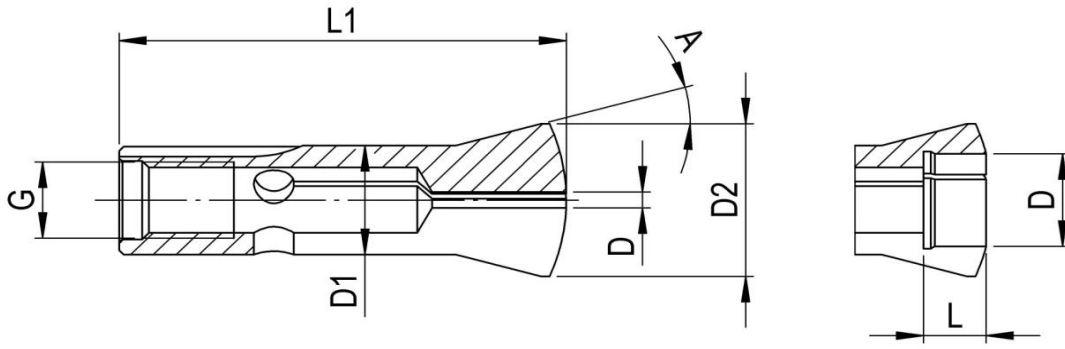

Abmessungen	D1	D2	L1	A	G
P4.5	ø4.5	ø6.75	22.9	15°	M3.35

Fabry Bestell Nr:	Alte-Nr.	Bohrung Form	L	Stufung	Bemerkungen
P4.5D...	78-00153	ø 00.20...02.50	-	0.1 mm	
		ø 02.60...03.00	8.5	0.1 mm	
		ø 03.10...04.00	4	0.1 mm	
		ø 04.10...04.50	3	0.1 mm	
Lieferbare Varianten		Rund D			
P4.5D...	78-00153	ø 00.70...04.50		0.01 mm	

Für grössere Mengen und für andere Ausführungen kontaktieren Sie bitte unseren Verkauf
Tel: +41 61 935 93 00, verkauf@fabry.ch, www.fabry.ch



Spannzangen Typ P5



Einheitsnummer -

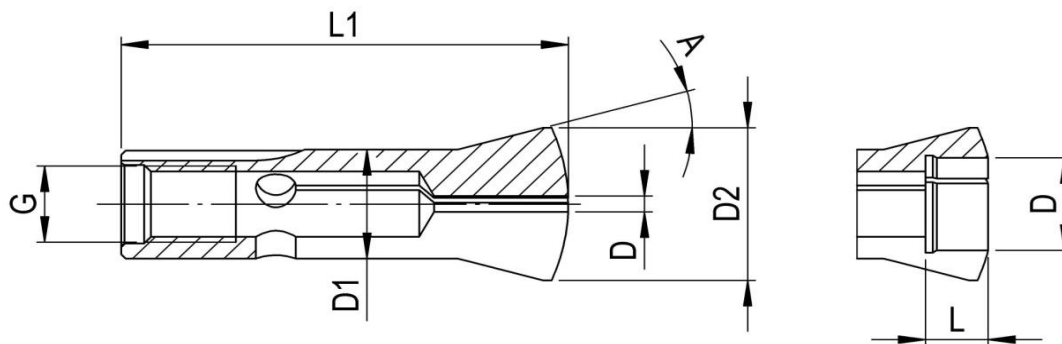

Abmessungen	D1	D2	L1	A	G	
P5	ø5	ø7	22.9	15°	M3.5	

Fabry Bestell Nr:	Alte-Nr.	Bohrung Form	L	Stufung	Bemerkungen
P5D...	78-00154	ø 00.20...01.50	-	0.1 mm	
		ø 02.00...02.50	-	0.5 mm	
		ø 03.00...03.50	8.5	0.5 mm	
		ø 04.00	4	0.5 mm	
		ø 04.50	3	0.5 mm	
		ø 05.00	2	0.5 mm	

Lieferbare Varianten	Rund D				
P5D...	ø 00.70...05.00			0.01 mm	

Für grössere Mengen und für andere Ausführungen kontaktieren Sie bitte unseren Verkauf
Tel: +41 61 935 93 00, verkauf@fabry.ch, www.fabry.ch

Spezifikation
Spannzangen



FABRY AG
SPANNZANGEN-TECHNOLOGIE
CNC-Bearbeitung Drehen Fräsen Schleifen

Spannzangen Typ P6



Einheitsnummer -

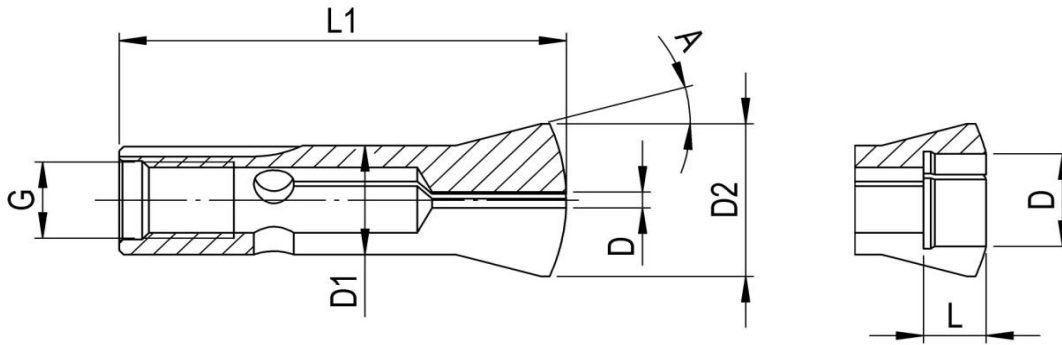

Abmessungen	D1	D2	L1	A	G	
P6	ø6	ø8.5	27.2	15°	M4	

Fabry Bestell Nr:	Alte-Nr.	Bohrung Form	L	Stufung	Bemerkungen
P6D...	78-00150	ø 00.40...02.00	-	0.1 mm	
		ø 02.50...03.00	-	0.5 mm	
		ø 03.50...04.50	11.5	0.5 mm	
		ø 05.00	4.5	0.5 mm	
Lieferbare Varianten		Rund D			
P6D...	78-00150	ø 00.70...05.00		0.01 mm	

Für grössere Mengen und für andere Ausführungen kontaktieren Sie bitte unseren Verkauf
Tel: +41 61 935 93 00, verkauf@fabry.ch, www.fabry.ch



Spannzangen Typ P9



Einheitsnummer -

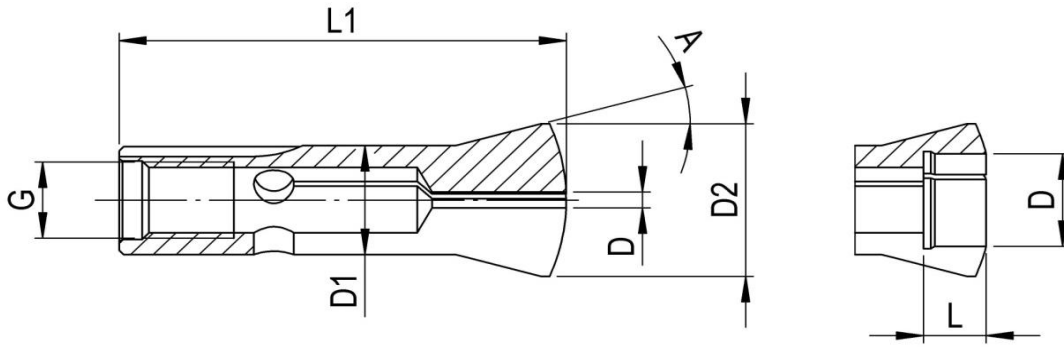

Abmessungen	D1	D2	L1	A	G
P9	ø9	ø13.2	39.3	15°	M6

Fabry Bestell Nr:	Alte-Nr.	Bohrung Form	L	Stufung	Bemerkungen
P9D...	78-00157	ø 00.50...02.00	-	0.1 mm	
		ø 02.50...04.50	-	0.5 mm	
		ø 05.00...07.00	12	0.5 mm	
		ø 07.50...08.00	7	0.5 mm	
		ø 08.50...09.00	5	0.5 mm	
Lieferbare Varianten		Rund D			
P9D...		ø 00.70...09.00		0.01 mm	

Für grössere Mengen und für andere Ausführungen kontaktieren Sie bitte unseren Verkauf
Tel: +41 61 935 93 00, verkauf@fabry.ch, www.fabry.ch

Spezifikation
Spannzangen



FABRY AG
SPANNZANGEN-TECHNOLOGIE
CNC-Bearbeitung Drehen Fräsen Schleifen

Spannzangen Typ P10

FAB

Einheitsnummer -

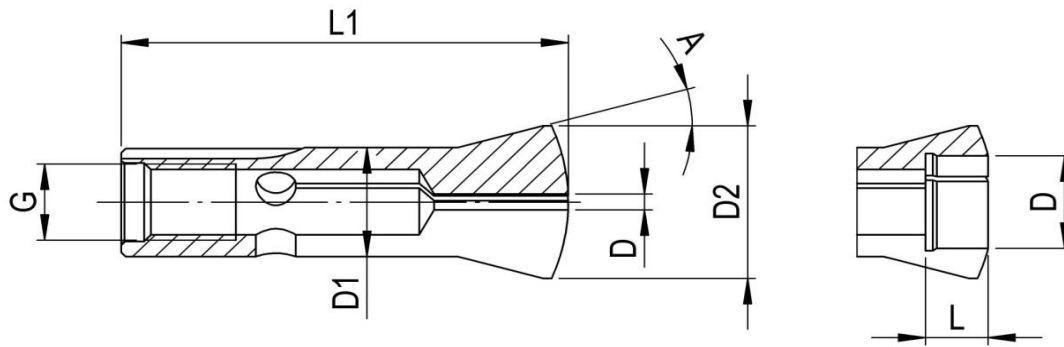

Abmessungen	D1	D2	L1	A	G	
P10	ø10	ø14	39	15°	M7	

Fabry Bestell Nr:	Alte-Nr.	Bohrung Form	L	Stufung	Bemerkungen
P10D...	78-00228	ø 00.50...05.50	-	0.5 mm	
		ø 06.00...08.00	21.5	1.0 mm	
		ø 09.00	5	1.0 mm	
		ø 10.00	3	1.0 mm	
Lieferbare Varianten		Rund D			
P10D...	78-00228	ø 00.70...10.00		0.01 mm	

Für grössere Mengen und für andere Ausführungen kontaktieren Sie bitte unseren Verkauf
Tel: +41 61 935 93 00, verkauf@fabry.ch, www.fabry.ch

Spezifikation
Spannzangen



FABRY AG

SPANNZANGEN-TECHNOLOGIE
CNC-Bearbeitung Drehen Fräsen Schleifen

Spannzangen Typ P25 / P36



Einheitsnummer -

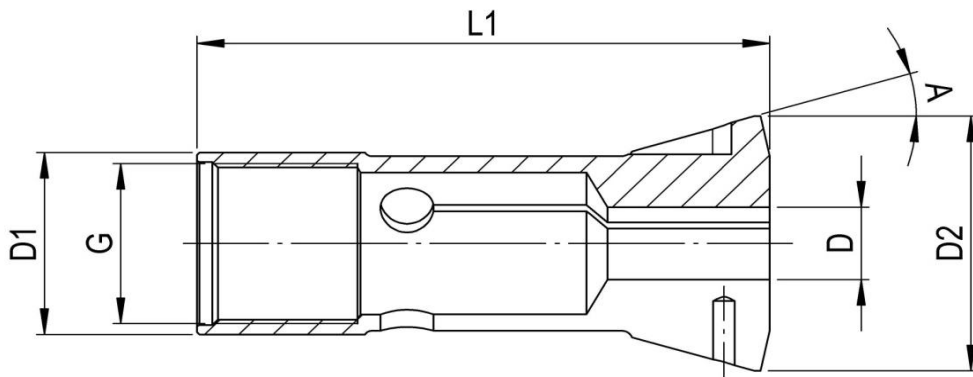

Abmessungen	D1	D2	L1	A	G	
P25	ø25	ø35	75	16°	M22x1	
P36	ø36	ø45	107	16°	M33x1.25	

Fabry Bestell Nr:	Alte-Nr.	Bohrung Form	Stufung	Bemerkungen
Standard		Rund D		
P25D...	78-00334	ø 03.00...15.00	0.5 mm	
P36D...	78-02007	ø 03.00...21.00	0.5 mm	
Lieferbare Varianten		Rund D		
P25D...	78-00334	ø 03.00...15.00	0.01 mm	
P36D...	78-02007	ø 03.00...21.00	0.01 mm	

Für grössere Mengen und für andere Ausführungen kontaktieren Sie bitte unseren Verkauf
Tel: +41 61 935 93 00, verkauf@fabry.ch, www.fabry.ch



Restposten Spannzangen Typ W8 - W20



Einheitsnummer -

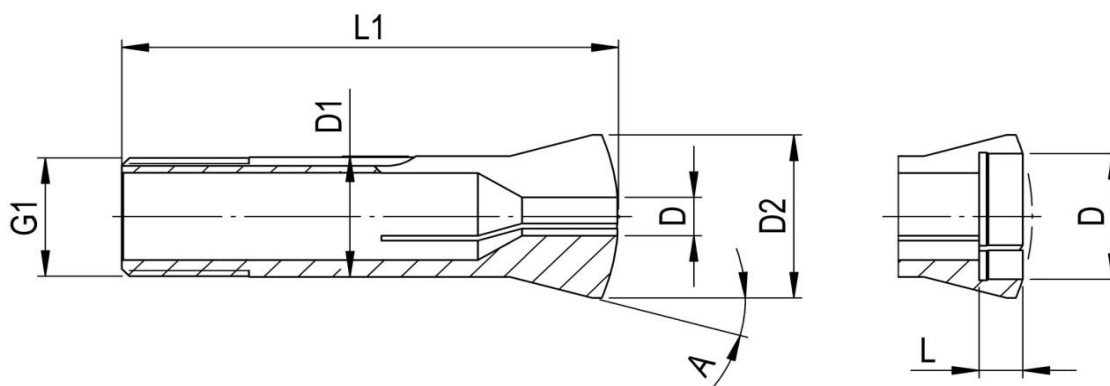

Abmessungen	D1	D2	L1	A	G1	
W8(80-01001)	8	10.85	33	10°	M8x0.75	Kopf 6-Kant SW6
W10(80-01509)	10	14	34	15°	M6x0.75	Kopf 4-Kant SW11
W16(80-00653)	16	22	61	15°	15.9x1.25 45°/5°	
W16.5(80-00586)	16.5	21.5	71	12°	16.3x26 60°	
W20(80-00111)	20	27	80	15°	19.75x2 45°/5°	

Fabry Bestell Nr:	Alte-Nr.	Bohrung Form	L	Stufung	Bemerkungen
Standard		Rund D			
W8(80-01001)	80-01001	ø1.00 - 05.50	-	0.5 mm	Restposten
W10(80-01509)	80-01509	ø2.00 - 05.00	-	0.5 mm	Restposten
W10(80-01509)	80-01509	ø5.50 - 08.00	18	0.5 mm	Restposten
W16(80-00653)	80-00653	ø1.00 - 12.00	-	0.5 mm	Restposten
W16(80-00653)	80-00653	ø12.50 - 14.00	5.5	0.5 mm	Restposten
W16.5(80-00586)	80-00586	ø1.50 - 13.00	-	0.5 mm	Restposten
W20(80-00111)	80-00111	ø00.50 - 14.50	-	0.5 mm	Restposten
W20(80-00111)	80-00111	ø15.00 - 19.50	7.5	0.5 mm	Restposten

Für grössere Mengen und für andere Ausführungen kontaktieren Sie bitte unseren Verkauf

Tel: +41 61 935 93 00, verkauf@fabry.ch, www.fabry.ch

Spezifikation
Spannzangen



FABRY AG
SPANNZANGEN-TECHNOLOGIE
CNC-Bearbeitung Drehen Fräsen Schleifen

Spannzangen Typ W10



Einheitsnummer 314E

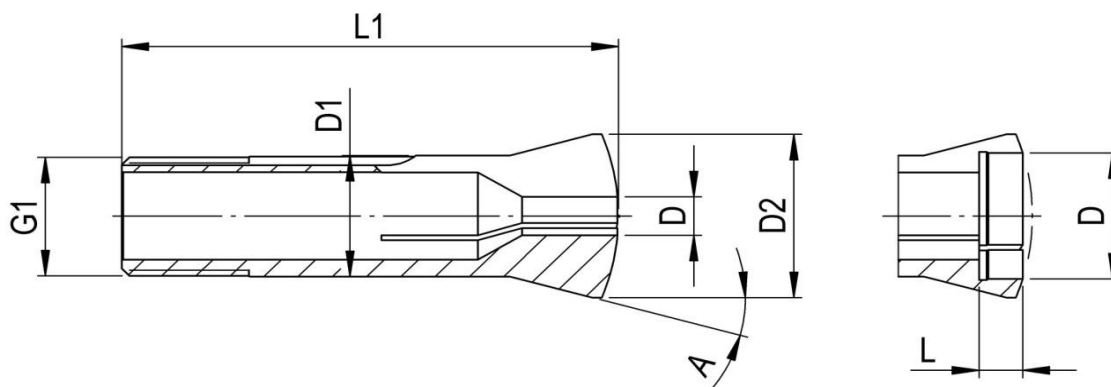

Abmessungen	D1	D2	L1	A	G1
W10	ø10	ø14	43.6	15°	ø9.83 x 0.833 - 45°/5°

Fabry Bestell Nr:	Alte-Nr.	Bohrung Form	L	Stufung	Bemerkungen
Standard		Rund D			
W10D...	80-00001	ø 01.00...03.00	-	0.1 mm	
		ø 03.50...06.50	-	0.5 mm	
		ø 07.00...08.00	15	0.5 mm	
		ø 08.50	6	0.5 mm	
		ø 09.00	5	0.5 mm	
		ø 09.50	4	0.5 mm	
		ø 10.00	3	0.5 mm	
Lieferbare Varianten		Rund D			
W10D...	80-00001	ø 01.00...10.00		0.01 mm	

Für grössere Mengen und für andere Ausführungen kontaktieren Sie bitte unseren Verkauf
Tel: +41 61 935 93 00, verkauf@fabry.ch, www.fabry.ch

Spezifikation
Spannzangen



FABRY AG
SPANNZANGEN-TECHNOLOGIE
CNC-Bearbeitung Drehen Fräsen Schleifen

Spannzangen Typ W12



Einheitsnummer 318E

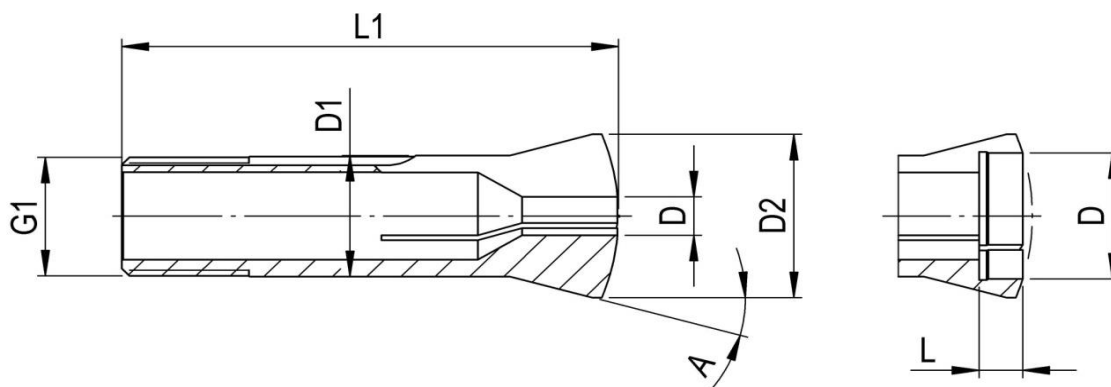

Abmessungen	D1	D2	L1	A	G1
W12	ø12	ø16	46	15°	ø11.75 x 1.25 - 45°/5°

Fabry Bestell Nr:	Alte-Nr.	Bohrung Form	L	Stufung	Bemerkungen
Standard		Rund D			
W12D...	80-00002	ø 00.30...02.90	-	0.1 mm	
		ø 03.00...08.00	-	0.5 mm	
		ø 08.50...10.00	17	0.5 mm	
		ø 10.50	6	0.5 mm	
		ø 11.00	5	0.5 mm	
		ø 11.50	4	0.5 mm	
		ø 12.00	3	0.5 mm	
		ø 12.50	2	0.5 mm	
Lieferbare Varianten		Rund D			
W12D...	80-00002	ø 00.70...12.50		0.01 mm	

Für grössere Mengen und für andere Ausführungen kontaktieren Sie bitte unseren Verkauf
Tel: +41 61 935 93 00, verkauf@fabry.ch, www.fabry.ch



Schnabelspannzangen Typ W12SL8.8



Einheitsnummer -

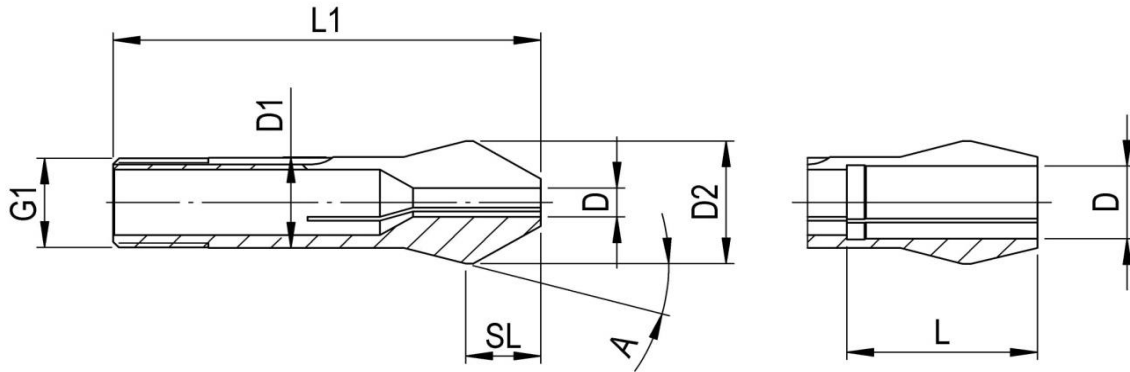

Abmessungen	D1	D2	L1	SL	A	G1
W12SL8.8	ø12	ø16	52	8.8	15°	ø11.75 x 1.25 - 45°/5°

Fabry Bestell Nr:	Alte-Nr.	Bohrung Form	L	Stufung	Bemerkungen
Standard		Rund D			
W12SL8.8D...	80-93108	ø 00.50...08.00	-	0.5 mm	
		ø 08.50...10.00	24	0.5 mm	
Lieferbare Varianten		Rund D			
W12SL8.8D...	80-93108	ø 00.70...10.00		0.01 mm	

Für grössere Mengen und für andere Ausführungen kontaktieren Sie bitte unseren Verkauf
Tel: +41 61 935 93 00, verkauf@fabry.ch, www.fabry.ch



Spannzangen Typ W15



Einheitsnummer 321E

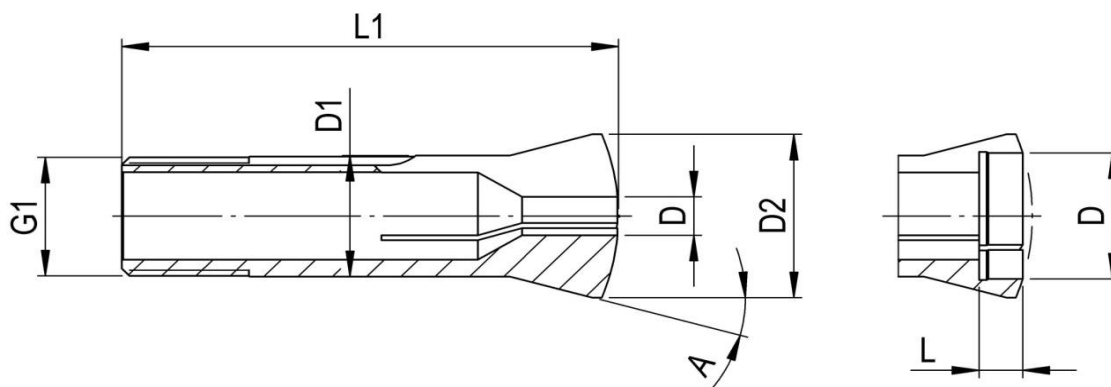

Abmessungen	D1	D2	L1	A	G1
W15	ø15	ø20.2	58.3	15°	ø14.75 x 1.25 - 45°/5°

Fabry Bestell Nr:	Alte-Nr.	Bohrung Form	L	Stufung	Bemerkungen
Standard		Rund D			
W15D...	80-00003	ø 00.50...02.90	-	0.1 mm	
		ø 03.00...10.50	-	0.5 mm	
		ø 11.00...12.50	22	0.5 mm	
		ø 13.00	9.5	0.5 mm	
		ø 13.50	8.5	0.5 mm	
		ø 14.00	7.5	0.5 mm	
		ø 14.50	6.5	0.5 mm	
		ø 15.00	5.5	0.5 mm	
		ø 15.50	4.5	0.5 mm	
		ø 16.00	3.5	0.5 mm	
Lieferbare Varianten		Rund D			
W15D...	80-00003	ø 00.70...16.00		0.01 mm	

Für grössere Mengen und für andere Ausführungen kontaktieren Sie bitte unseren Verkauf

Tel: +41 61 935 93 00, verkauf@fabry.ch, www.fabry.ch



Schnabelspannzangen Typ W15SL12



Einheitsnummer -

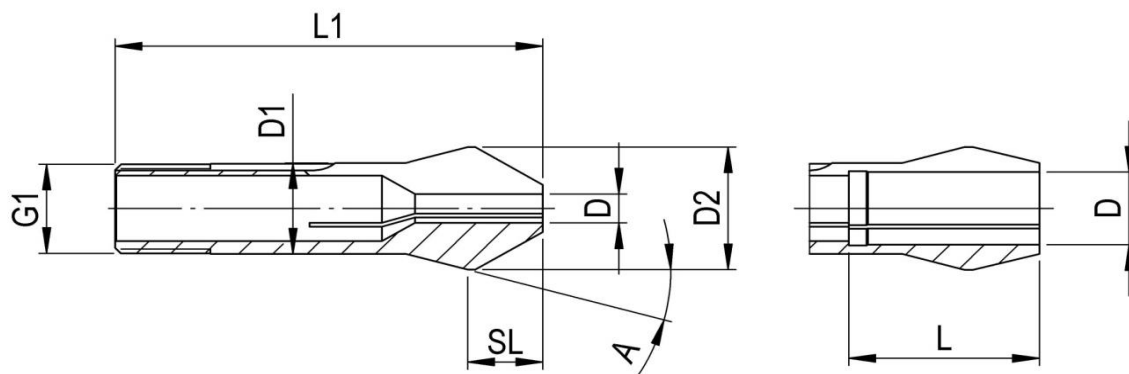

Abmessungen	D1	D2	L1	SL	A	G1
W15SL12	ø15	ø20.2	67	12	15°	ø14.75 x 1.25 - 45°/5°

Fabry Bestell Nr:	Alte-Nr.	Bohrung Form	L	Stufung	Bemerkungen
Standard		Rund D			
W15SL12D...UP	80-93285	ø 01.00...04.50	-	0.5 mm	
		ø 05.00...10.00	-	1.0 mm	
		ø 11.00...12.00	32	1.0 mm	
Lieferbare Varianten		Rund D			
W15SL12D...UP	80-93285	ø 01.00...12.00		0.01 mm	

Für grössere Mengen und für andere Ausführungen kontaktieren Sie bitte unseren Verkauf
 Tel: +41 61 935 93 00, verkauf@fabry.ch, www.fabry.ch

Spezifikation
Spannzangen



FABRY AG
SPANNZANGEN-TECHNOLOGIE
CNC-Bearbeitung Drehen Fräsen Schleifen

Spannzangen Typ W20



Einheitsnummer 349E

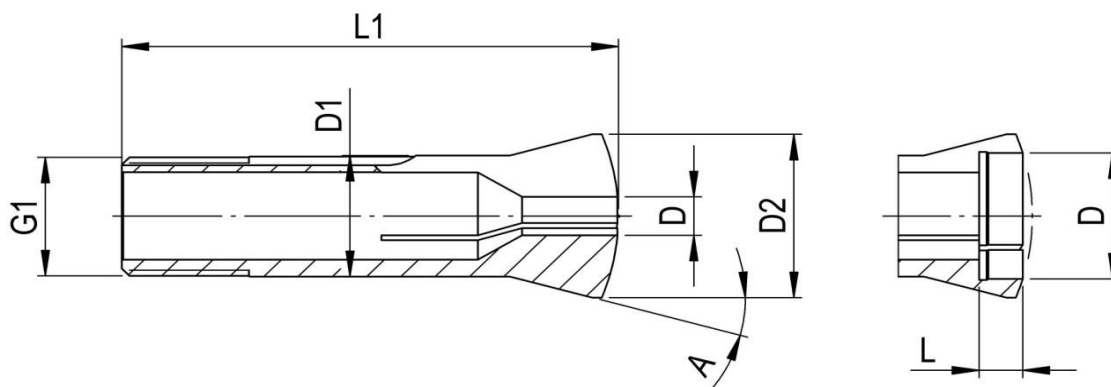

Abmessungen	D1	D2	L1	A	G1
W20	ø20	ø26.3	73	15°	ø19.7 x 1.667 - 45°/5°

Fabry Bestell Nr:	Alte-Nr.	Bohrung Form	L	Stufung	Bemerkungen
Standard		Rund D			
W20D...	80-00004	ø 00.30...03.00	-	0.1 mm	
		ø 03.50...14.50	-	0.5 mm	
		ø 15.00...16.00	28	0.5 mm	
Lieferbare Varianten		Rund D			
W20D...	80-00004	ø 00.70...16.00		0.01 mm	
Standard		Sechskant SK			
W20SK...	80-00004	ø 04.00...16.00		1.0 mm	
Lieferbare Varianten		Sechskant SK			
W20SK...	80-00004	ø 04.00...16.00		0.01 mm	
Standard		Vierkant VK			
W20VK...	80-00004	ø 04.00...14.00		1.0 mm	
Lieferbare Varianten		Vierkant VK			
W20VK...	80-00004	ø 04.00...14.00		0.01 mm	

Für grössere Mengen und für andere Ausführungen kontaktieren Sie bitte unseren Verkauf
Tel: +41 61 935 93 00, verkauf@fabry.ch, www.fabry.ch

Spezifikation
Spannzangen



FABRY AG

SPANNZANGEN-TECHNOLOGIE
CNC-Bearbeitung Drehen Fräsen Schleifen

Spannzangen Typ W20V

FAB

Einheitsnummer 349E

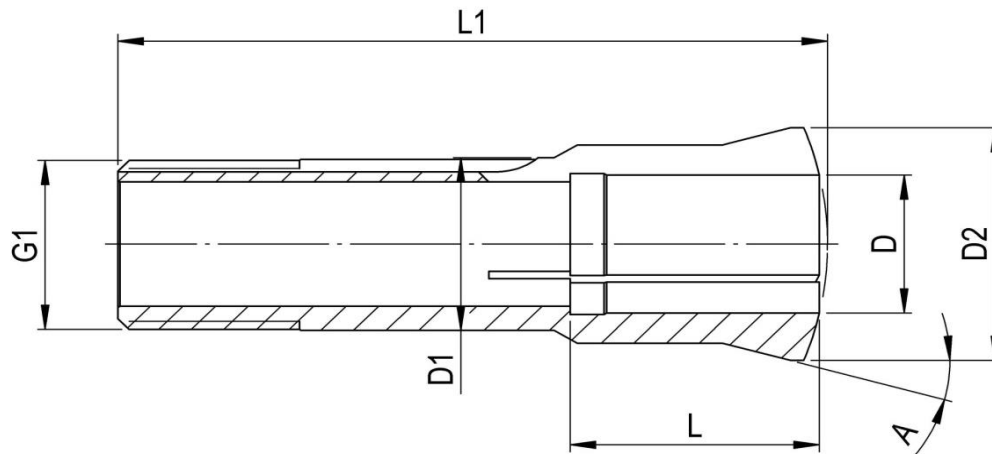

Abmessungen	D1	D2	L1	A	G1
W20V	ø20	ø26.3	73	15°	ø19.7 x 1.667 - 45°/5°

Fabry Bestell Nr:	Alte-Nr.	Bohrung Form	L	Stufung	Bemerkungen
Standard		Rund D			
W20VD...	80-00107	ø 16.50...20.00	24	0.5 mm	
Lieferbare Varianten		Rund D			
W20VD...	80-00107	ø 16.00...20.00		0.01 mm	

Für grössere Mengen und für andere Ausführungen kontaktieren Sie bitte unseren Verkauf
Tel: +41 61 935 93 00, verkauf@fabry.ch, www.fabry.ch

Spezifikation
Spannzangen



FABRY AG

SPANNZANGEN-TECHNOLOGIE
CNC-Bearbeitung Drehen Fräsen Schleifen

Schnabelspannzangen Typ W20SL15.5

FAB

Einheitsnummer 349E

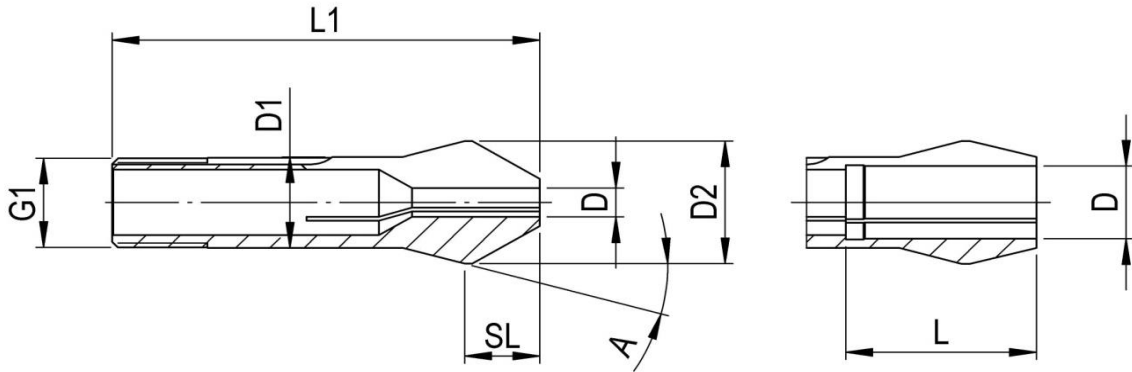

Abmessungen	D1	D2	L1	SL	A	G1
W20SL15.5	ø20	ø26.3	84.5	15.5	15°	ø19.7 x 1.667 - 45°/5°

Fabry Bestell Nr:	Alte-Nr.	Bohrung Form	L	Stufung	Bemerkungen
Standard		Rund D			
W20SL15.5D...	80-92744	ø 00.50...13.00	-	0.5 mm	
		ø 13.50...16.00	41	0.5 mm	
Lieferbare Varianten		Rund D			
W20SL15.5D...	80-92744	ø 00.70...16.00		0.01 mm	

Für grössere Mengen und für andere Ausführungen kontaktieren Sie bitte unseren Verkauf
Tel: +41 61 935 93 00, verkauf@fabry.ch, www.fabry.ch

Spezifikation
Spannzangen



FABRY AG

SPANNZANGEN-TECHNOLOGIE
CNC-Bearbeitung Drehen Fräsen Schleifen

Spannzangen Typ W25

FAB

Einheitsnummer 364 E

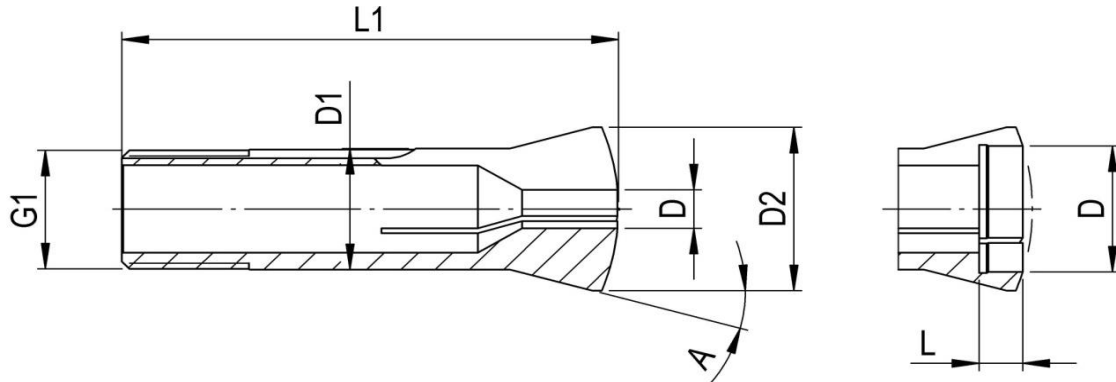

Abmessungen	D1	D2	L1	A	G1
W25	ø25	ø33.7	97.6	15°	ø24.7 x 1.693 - 45°/5°

Fabry Bestell Nr:	Alte-Nr.	Bohrung Form	L	Stufung	Bemerkungen
Standard		Rund D			
W25D...	80-00005	ø 00.50...19.00	-	0.5 mm	
		ø 19.50...21.00	35	0.5 mm	
Lieferbare Varianten		Rund D			
W25D...	80-00005	ø 00.70...21.00		0.01 mm	
Standard		Sechskant SK			
W25SK...	80-00005	ø 04.00...20.00		1.0 mm	
Standard		Vierkant VK			
W25VK...	80-00005	ø 04.00...16.00		1.0 mm	

Für grössere Mengen und für andere Ausführungen kontaktieren Sie bitte unseren Verkauf
Tel: +41 61 935 93 00, verkauf@fabry.ch, www.fabry.ch

Spezifikation
Spannzangen



FABRY AG

SPANNZANGEN-TECHNOLOGIE
CNC-Bearbeitung Drehen Fräsen Schleifen

Spannzangen Typ W31.75



Einheitsnummer 385 E

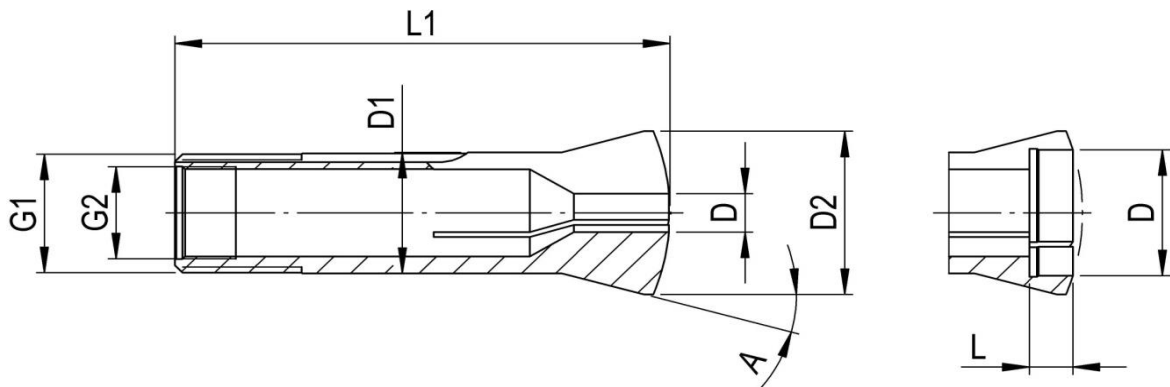

Abmessungen	D1	D2	L1	A	G1	G2
W31.75	ø31.75	ø37.4	87	10°3'	ø31.4x1.27 - 60°	ø26.44x1.058 - 60°

Fabry Bestell Nr:	Alte-Nr.	Bohrung Form	L	Stufung	Bemerkungen
Standard		Rund D			
W31.75D...	80-00842	ø 01.00...25.00	-	0.5 mm	
		ø 25.50...27.50	40	0.5 mm	
		ø 28.00...28.50	10	0.5 mm	
		ø 29.00...29.50	7	0.5 mm	
		ø 30.00...31.00	4	0.5 mm	
Lieferbare Varianten		Rund D			
W31.75D...	80-00842	ø 01.00...31.00		0.01 mm	
W31.75VK...	80-00842	ø 08.00...18.00			auf Anfrage
W31.75SK...	80-00842	ø 08.00...21.00			auf Anfrage

Für grössere Mengen und für andere Ausführungen kontaktieren Sie bitte unseren Verkauf
Tel: +41 61 935 93 00, verkauf@fabry.ch, www.fabry.ch

Spezifikation
Spannzangen



FABRY AG

SPANNZANGEN-TECHNOLOGIE
CNC-Bearbeitung Drehen Fräsen Schleifen

Spannzangen Typ HW20V



Einheitsnummer -

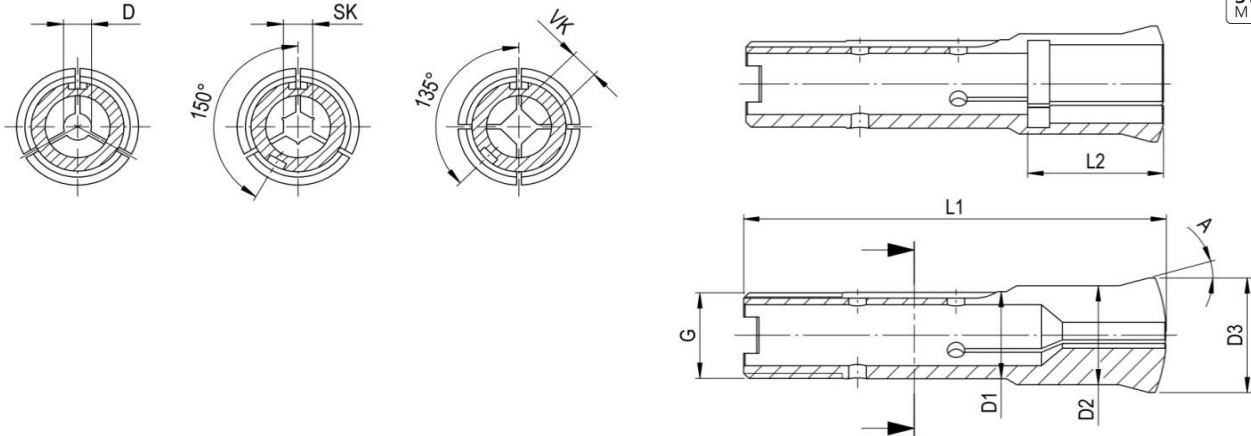

Abmessungen	D1	D2	D3	L1	A	G
HW20V	20	22.7	26.3	96.5	15°	ø19.7 x 1.667 - 45°/5°

Fabry Bestell Nr:	Alte-Nr.	Bohrung Form	L2	Stufung	Bemerkungen
Standard		Rund D			
HW20V22.7D...	80-02030	03.00..13.50	-	0.50 mm	
		14.00..20.00	31	0.50 mm	L2 => ab ø 13.8mm
Lieferbare Varianten		Sechskant SK			
HW20V22.7SK...	80-02030	03.00..11.79	-	0.01 mm	
		11.80..17.00	31	0.01 mm	
Lieferbare Varianten		Vierkant VK			
HW20V22.7VK...	80-02040	03.00..09.59	-	0.01 mm	
		09.60..14.00	31	0.01 mm	

Für grössere Mengen und für andere Ausführungen kontaktieren Sie bitte unseren Verkauf
Tel: +41 61 935 93 00, verkauf@fabry.ch, www.fabry.ch

Spezifikation
Spannzangen



FABRY AG

SPANNZANGEN-TECHNOLOGIE
CNC-Bearbeitung Drehen Fräsen Schleifen

Spannzangen Typ HW25V

FAB

Einheitsnummer -

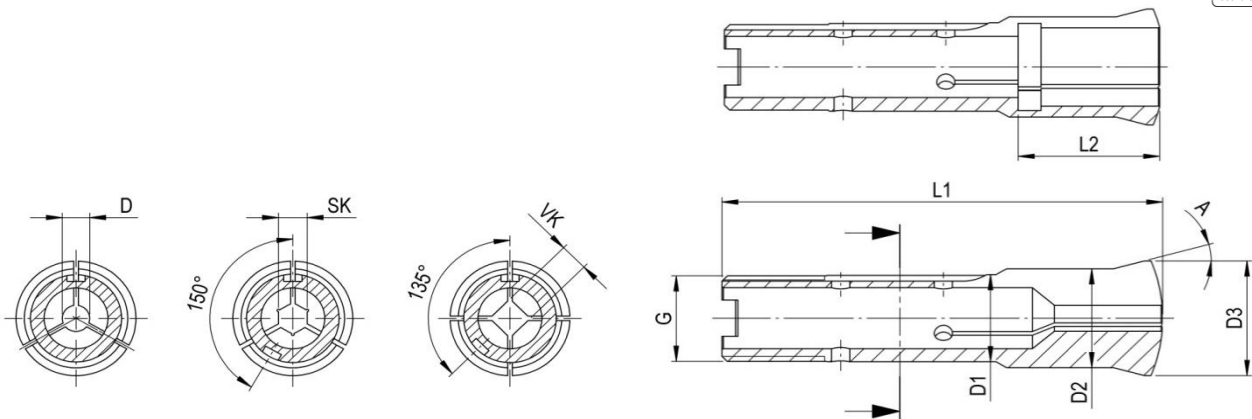

Abmessungen	D1	D2	D3	L1	A	G
HW25V	ø25	ø28.7	ø33.7	97.6	15°	ø24.7 x 1.693 - 45°/5°

Fabry Bestell Nr:	Alte-Nr.	Bohrung Form	L2	Stufung	Bemerkungen
Standard		Rund D			
HW25V28.7D...	80-02033	03.00..17.50	-	0.50 mm	
		18.00..25.00	31	0.50 mm	L2 => ab ø 17.8mm
Lieferbare Varianten		Sechskant SK			
HW25V28.7SK...	80-02033	03.00 - 15.29	-	0.01 mm	
		15.30 - 22.00	31	0.01 mm	
Lieferbare Varianten		Vierkant VK			
HW25V28.7VK...	80-02043	03.00 - 12.49	-	0.01 mm	
		12.50 - 18.00	31	0.01 mm	

Für grössere Mengen und für andere Ausführungen kontaktieren Sie bitte unseren Verkauf

Tel: +41 61 935 93 00, verkauf@fabry.ch, www.fabry.ch

Spezifikation
Spannzangen



FABRY AG

SPANNZANGEN-TECHNOLOGIE
CNC-Bearbeitung Drehen Fräsen Schleifen

Spannzangen Typ HB32

FAB

Einheitsnummer -

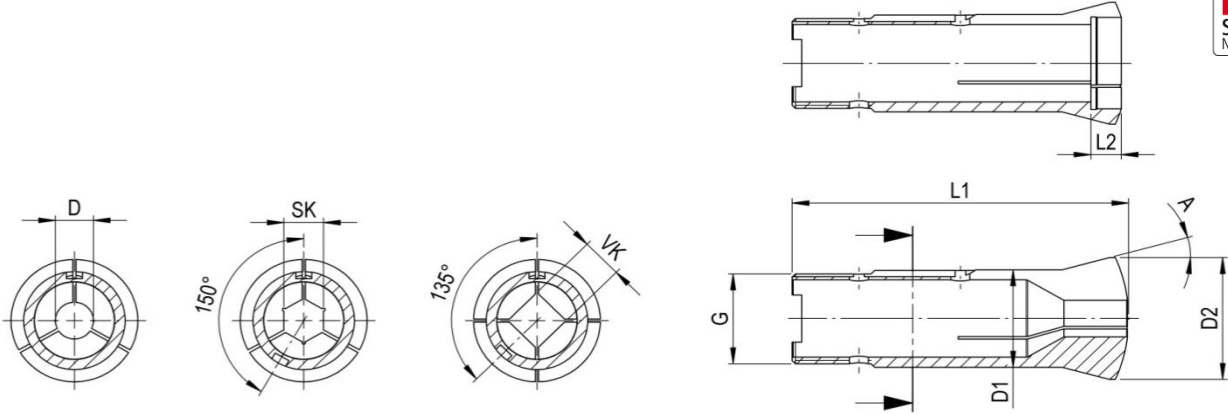

Abmessungen	D1	D2	L1	A	G		
HB32	ø32	ø40	106	15°	ø29.7 x 1.693 - 45°/5°		

Fabry Bestell Nr:	Alte-Nr.	Bohrung Form	L2	Stufung	Bemerkungen
Standard		Rund D			
HB32D...	72-02030	ø 3.0...23.50	-	0.50 mm	
		ø 24.00...27.50	44	0.50 mm	L2 => ab 23.8mm
		ø 28.00...29.50	12	0.50 mm	
		ø 30.00...32.00	8	0.50 mm	
lieferbare Varianten		Sechskant			
HB32SK...	72-02030	SK 3.00...20.59	-	0.01 mm	
		SK 20.60...23.99	44	0.01 mm	
		SK 24.00...25.49	12	0.01 mm	
		SK 25.50...27.00	8	0.01 mm	
lieferbare Varianten		Vierkant VK			
HB32VK...	72-02040	VK 3.00...16.99	-	0.01 mm	
		VK 17.00...19.79	44	0.01 mm	
		VK 19.80...20.99	12	0.01 mm	
		VK 21.00...22.60	8	0.01 mm	

Für grössere Mengen und für andere Ausführungen kontaktieren Sie bitte unseren Verkauf
Tel: +41 61 935 93 00, verkauf@fabry.ch, www.fabry.ch

Spezifikation
Spannzangen



FABRY AG

SPANNZANGEN-TECHNOLOGIE
CNC-Bearbeitung Drehen Fräsen Schleifen

Spannzangen Typ HB32/45

FAB

Einheitsnummer -

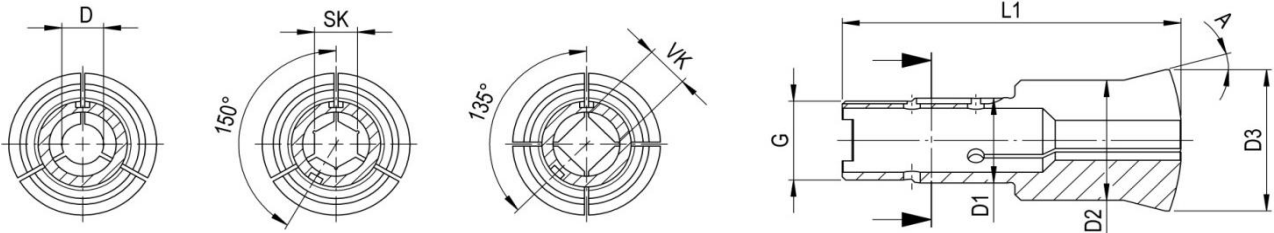

Abmessungen	D1	D2	D3	L1	A	G
HB32/45	ø32	ø45	ø53	122	15°	ø29.7 x 1.693 - 45°/5°

Fabry Bestell Nr:	Alte-Nr.	Bohrung Form	L2	Stufung	Bemerkungen
Standard		Rund D			
HB32/45D...	72-02033	ø 03.00...23.50	-	0.50 mm	
		ø 24.00...40.50	50	0.50 mm	L2 => ab ø 23.8mm
		ø 41.00...41.50	14	0.50 mm	
		ø 42.00...42.50	12	0.50 mm	
		ø 43.00...43.50	10	0.50 mm	
		ø 44.00...45.00	8	0.50 mm	
Lieferbare Varianten		Sechskant SK			
HB32/45SK...	72-02033	ø 3.00...20.59	-	0.01 mm	
		ø 20.60...34.99	50	0.01 mm	
		ø 35.00...35.99	14	0.01 mm	
		ø 36.00...36.99	12	0.01 mm	
		ø 37.00...37.99	10	0.01 mm	
		ø 38.00...38.50	8	0.01 mm	
Lieferbare Varianten		Vierkant VK			
HB32/45VK...	72-02043	ø 3.00...16.79	-	0.01 mm	
		ø 16.80...28.99	50	0.01 mm	
		ø 29.00...29.99	12	0.01 mm	
		ø 30.00...30.99	10	0.01 mm	
		ø 31.00...31.75	8	0.01 mm	

Für grössere Mengen und für andere Ausführungen kontaktieren Sie bitte unseren Verkauf
Tel: +41 61 935 93 00, verkauf@fabry.ch, www.fabry.ch

Spezifikation
Spannzangen



FABRY AG
SPANNZANGEN-TECHNOLOGIE
CNC-Bearbeitung Drehen Fräsen Schleifen

Spannzangen Typ HB45

FAB

Einheitsnummer -

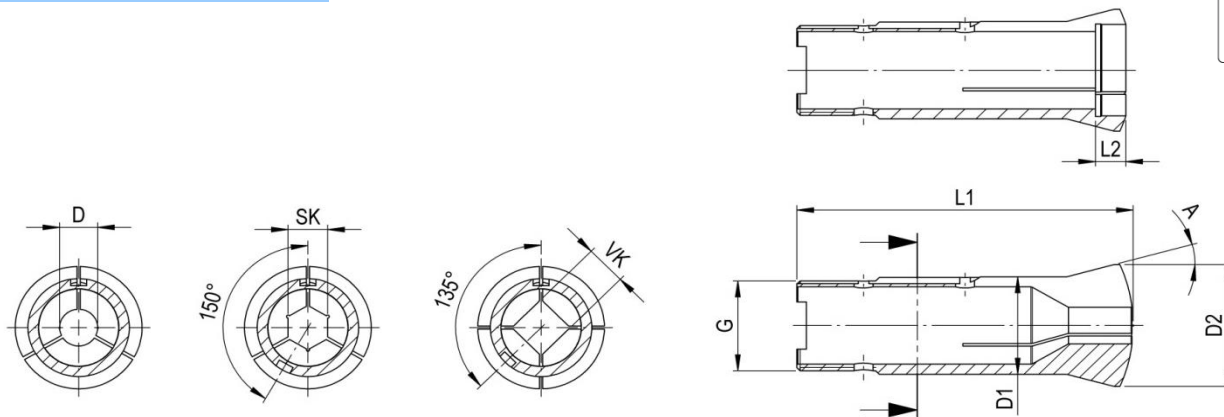

Abmessungen	D1	D2	L1	A	G			
HB45	ø45	ø53	115	15°	M42 x 1.5			

Fabry Bestell Nr:	Alte-Nr.	Bohrung Form	L2	Stufung	Bemerkungen
Standard		Rund D			
HB45D...	72-02036	ø 3.00...35.50	-	0.50 mm	
		ø 36.00...40.50	53	0.50 mm	L2 => ab ø 36.01 mm
		ø 41.00...41.50	14	0.01 mm	
		ø 42.00...42.50	12	0.01 mm	
		ø 43.00...43.50	10	0.01 mm	
		ø 44.00...45.00	8	0.01 mm	
lieferbare Varianten		Sechskant SK			
HB45SK...	72-02036	ø 3.00...31.00	-	0.01 mm	
		ø 31.01...34.99	53	0.01 mm	
		ø 35.00...35.99	14	0.01 mm	
		ø 36.00...36.99	12	0.01 mm	
		ø 37.00...37.99	10	0.01 mm	
		ø 38.00...38.50	8	0.01 mm	
lieferbare Varianten		Vierkant VK			
HB45VK...	72-02046	ø 3.00...25.40	-	0.01 mm	
		ø 25.41...28.99	53	0.01 mm	
		ø 29.00...29.99	12	0.01 mm	
		ø 30.00...30.99	10	0.01 mm	
		ø 31.00...31.75	8	0.01 mm	

Für grössere Mengen und für andere Ausführungen kontaktieren Sie bitte unseren Verkauf

Tel: +41 61 935 93 00, verkauf@fabry.ch, www.fabry.ch

Spezifikation
Spannzangen



FABRY AG
SPANNZANGEN-TECHNOLOGIE
CNC-Bearbeitung Drehen Fräsen Schleifen

Spannzangen Typ Index



Einheitsnummer SZ41

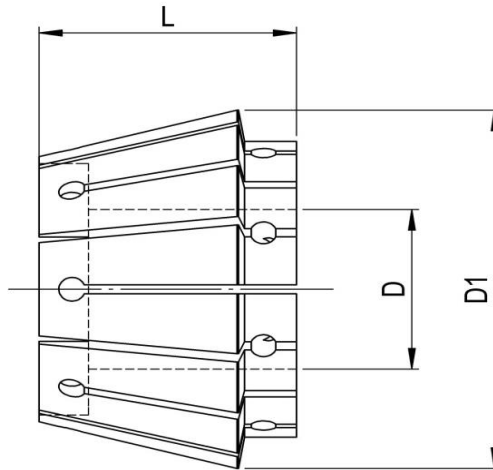

Abmessungen	D1	L					
INDEX	60	39					

Fabry Bestell Nr:	Alte-Nr.	Bohrung Form	Bohrung	Stufung	Bemerkungen
Standard		Rund D			
FIND03.00...42.00G	SZ 42	ø3.00 - ø42.00	Glatt	1.0 mm	
Lieferbare Varianten		Rund D			
FIND03.00...42.00G	SZ 42	ø3.00 - ø42.00	Glatt	0.01 mm	

Für grössere Mengen und für andere Ausführungen kontaktieren Sie bitte unseren Verkauf
Tel: +41 61 935 93 00, verkauf@fabry.ch, www.fabry.ch

**Spezifikation
Glockenzangen**



FABRY AG
SPANNZANGEN-TECHNOLOGIE
CNC-Bearbeitung Drehen Fräsen Schleifen

Glockenspannzangen Typ F12G



Einheitsnummer -

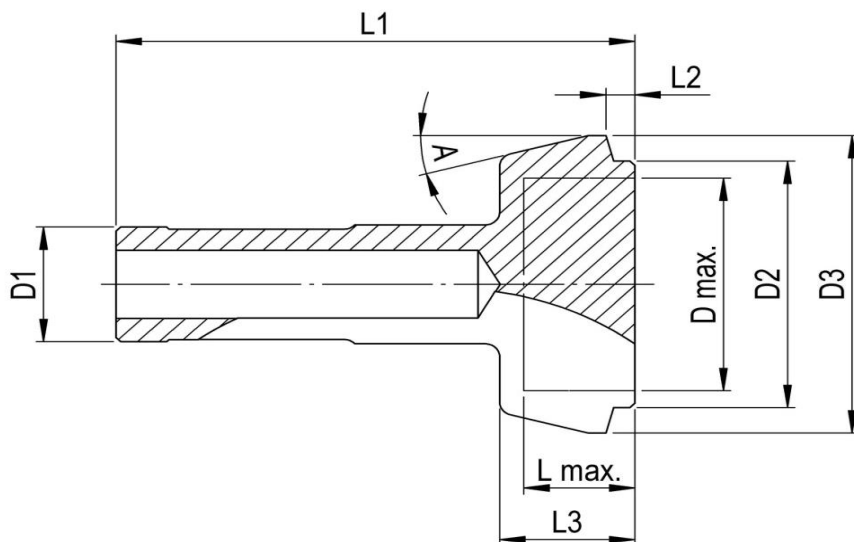

Abmessungen	D1	D2	D3	L1	L2	L3	A	
F12G01	ø12	ø33	ø39	60	5	13	15°	
F12G02	ø12	ø49	ø55	60	5	13	15°	
F12G03	ø12	ø65	ø71	60	5	13	15°	

Fabry Bestell Nr:	Alte-Nr.	L max.	D max.	Bemerkungen
Standard				
F12G01	82-31000	9	ø27	
F12G02	82-31001	9	ø43	
F12G03	82-31002	9	ø59	

Für grössere Mengen und für andere Ausführungen kontaktieren Sie bitte unseren Verkauf
Tel: +41 61 935 93 00, verkauf@fabry.ch, www.fabry.ch

Spezifikation
Glockenzangen



FABRY AG
SPANNZANGEN-TECHNOLOGIE
CNC-Bearbeitung Drehen Fräsen Schleifen

Glockenspannzangen Typ F27G



Einheitsnummer -

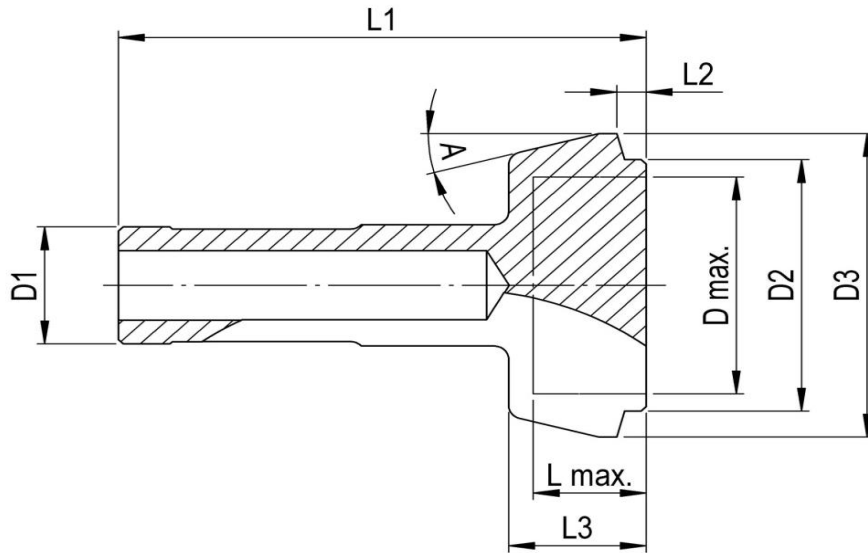

Abmessungen	D1	D2	D3	L1	L2	L3	A	
F27G01	ø27	ø58	ø70	107.5	6	28	15°	
F27G02	ø27	ø88	ø100	107.5	6	28	15°	
F27G03	ø27	ø118	ø130	107.5	6	28	15°	
F27G04	ø27	ø148	ø160	107.5	6	28	15°	

Fabry Bestell Nr:	Alte-Nr.	L max.	D max.	Bemerkungen
Standard				
F27G01	82-31003	23	ø50	
F27G02	82-31004	23	ø80	
F27G03	82-31005	23	ø110	
F27G04	82-31006	23	ø140	

Für grössere Mengen und für andere Ausführungen kontaktieren Sie bitte unseren Verkauf
Tel: +41 61 935 93 00, verkauf@fabry.ch, www.fabry.ch

Spezifikation
Glockenzangen



FABRY AG
SPANNZANGEN-TECHNOLOGIE
CNC-Bearbeitung Drehen Fräsen Schleifen

Glockenspannzangen Typ F38G



Einheitsnummer -

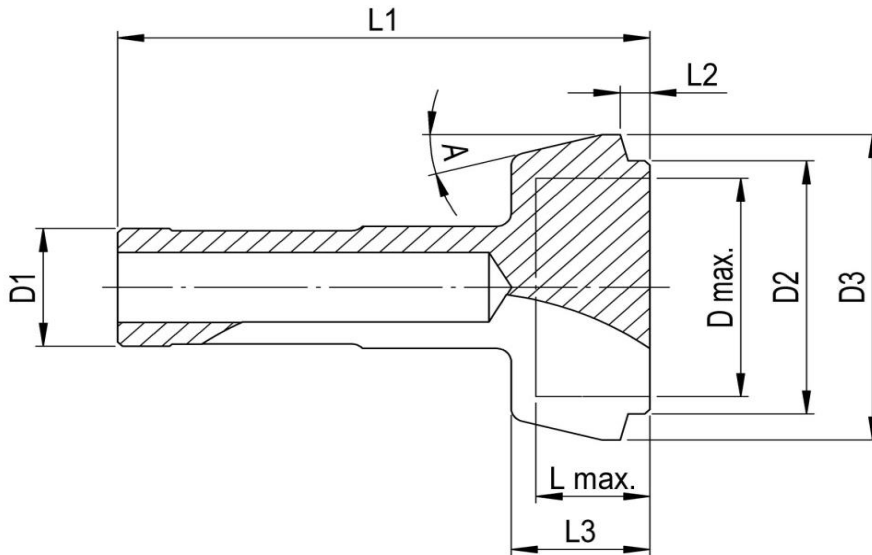

Abmessungen	D1	D2	D3	L1	L2	L3	A	
F38G01	ø38	ø58	ø70	139	6	28	15°	
F38G02	ø38	ø88	ø100	139	6	28	15°	
F38G03	ø38	ø118	ø130	139	6	28	15°	
F38G04	ø38	ø148	ø160	139	6	28	15°	

Fabry Bestell Nr:	Alte-Nr.	L max.	D max.	Bemerkungen
Standard				
F38G01	82-31007	23	ø50	
F38G02	82-31008	23	ø80	
F38G03	82-31009	23	ø110	
F38G04	82-31010	23	ø140	

Für grössere Mengen und für andere Ausführungen kontaktieren Sie bitte unseren Verkauf
Tel: +41 61 935 93 00, verkauf@fabry.ch, www.fabry.ch

Spezifikation
Glockenzangen



FABRY AG
SPANNZANGEN-TECHNOLOGIE
CNC-Bearbeitung Drehen Fräsen Schleifen

Glockenspannzangen Typ B32G



Einheitsnummer -

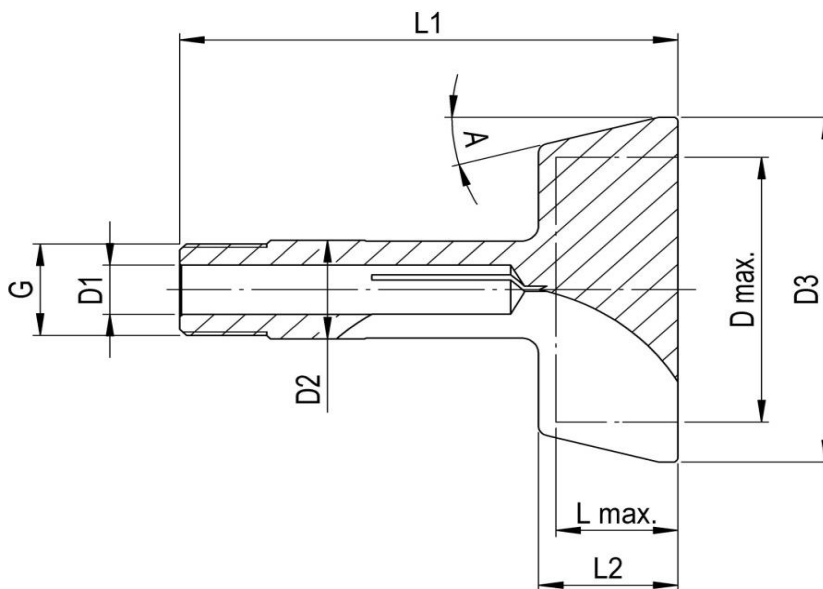

Abmessungen	D1	D2	D3	A	G
B32G01	ø16	ø32	70	15°	ø29.7 x 1.693 - 45°/5°
B32G02	ø16	ø32	112	15°	ø29.7 x 1.693 - 45°/5°
B32G03	ø16	ø32	152	15°	ø29.7 x 1.693 - 45°/5°
B32G04	ø16	ø32	192	15°	ø29.7 x 1.693 - 45°/5°

Fabry Bestell Nr:	Alte-Nr.	L1	L2	L max.	D max.	Bemerkungen
Standard						
B32G01	82-11000	143	40	35	ø44	
B32G02	82-11001	143	40	35	ø86	
B32G03	82-11002	143	40	35	ø126	
B32G04	82-11003	143	40	35	ø166	

Für grössere Mengen und für andere Ausführungen kontaktieren Sie bitte unseren Verkauf
Tel: +41 61 935 93 00, verkauf@fabry.ch, www.fabry.ch

Spezifikation
Glockenzangen



FABRY AG
SPANNZANGEN-TECHNOLOGIE
CNC-Bearbeitung Drehen Fräsen Schleifen

Glockenspannzangen Typ W12G



Einheitsnummer -

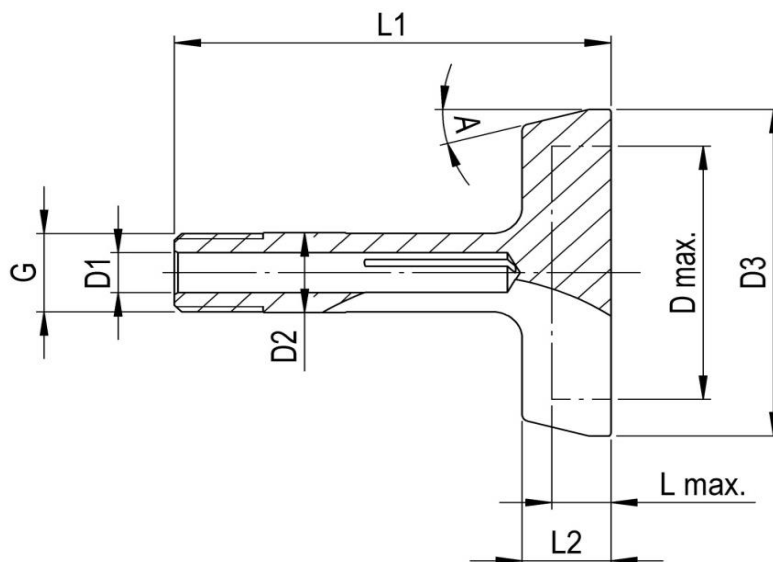

Abmessungen	D1	D2	D3	A	G
W12G01	ø6	ø12	33	15°	ø11.75 x 1.25 - 45°/5°
W12G02	ø6	ø12	49	15°	ø11.75 x 1.25 - 45°/5°
W12G03	ø6	ø12	65	15°	ø11.75 x 1.25 - 45°/5°
W12G04	ø6	ø12	81	15°	ø11.75 x 1.25 - 45°/5°
W12G05	ø6	ø12	97	15°	ø11.75 x 1.25 - 45°/5°

Fabry Bestell Nr:	Alte-Nr.	L1	L2	L max.	D max.	Bemerkungen
Standard						
W12G01	82-51006	59	12	8	ø22	
W12G02	82-51007	59	12	8	ø38	
W12G02SA4	82-51007	59	12	8	ø38	4-Schlitz
W12G03	82-51008	59	12	8	ø54	
W12G04	82-51009	59	12	8	ø70	
W12G05	82-51010	59	12	8	ø86	

Für grössere Mengen und für andere Ausführungen kontaktieren Sie bitte unseren Verkauf
Tel: +41 61 935 93 00, verkauf@fabry.ch, www.fabry.ch



Glockenspannzangen Typ W20G



Einheitsnummer -

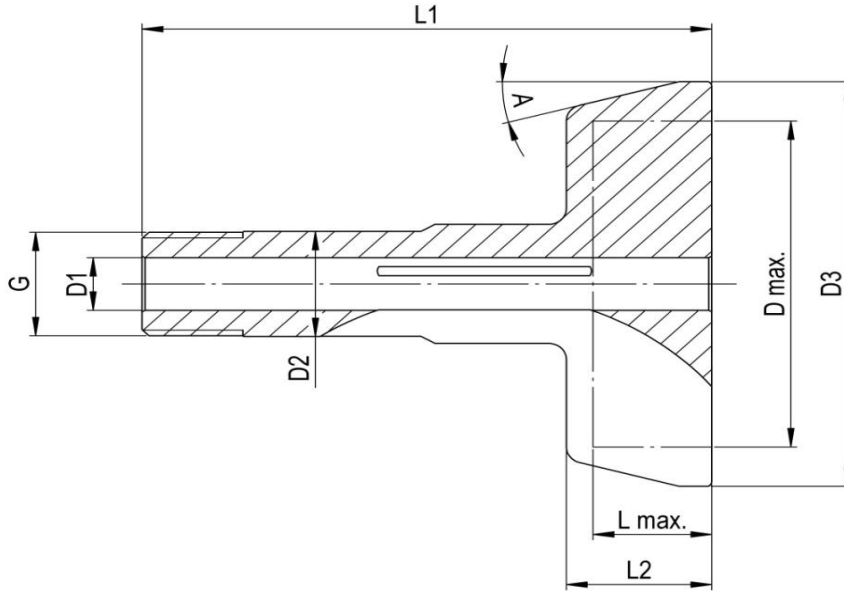

Abmessungen	D1	D2	D3	A	G
W20G02	ø10	ø20	56	15°	ø19.7 x 1.667 - 45°/5°
W20G03	ø10	ø20	77	15°	ø19.7 x 1.667 - 45°/5°
W20G04	ø10	ø20	98	15°	ø19.7 x 1.667 - 45°/5°
W20G05	ø10	ø20	120	15°	ø19.7 x 1.667 - 45°/5°
W20G06	ø10	ø20	140	15°	ø19.7 x 1.667 - 45°/5°

Fabry Bestell Nr:	Alte-Nr.	L1	L2	L max.	D max.	Bemerkungen
Standard						
W20G02	82-51001	96	24.5	20	ø40	
W20G03	82-51002	96	24.5	20	ø62	
W20G04	82-51003	96	24.5	20	ø82	
W20G05	82-51004	96	24.5	20	ø104	
W20G06	82-51005	96	24.5	20	ø124	

Für grössere Mengen und für andere Ausführungen kontaktieren Sie bitte unseren Verkauf
Tel: +41 61 935 93 00, verkauf@fabry.ch, www.fabry.ch

Spezifikation
Glockenzangen



FABRY AG
SPANNZANGEN-TECHNOLOGIE
CNC-Bearbeitung Drehen Fräsen Schleifen

Glockenspannzangen Typ W20G..ZL



Einheitsnummer -

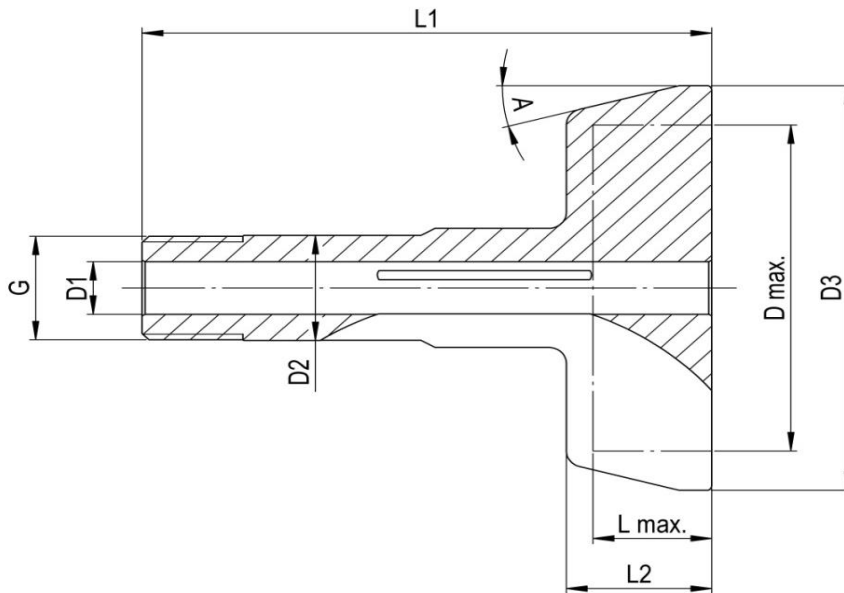

Abmessungen	D1	D2	D3	A	G
W20G02ZL	ø10	ø20	56	15°	ø19.7 x 1.667 - 45°/5°
W20G03ZL	ø10	ø20	77	15°	ø19.7 x 1.667 - 45°/5°

Fabry Bestell Nr:	Alte-Nr.	L1	L2	L max.	D max.	Bemerkungen
Standard						
W20G02ZL35SA4	82-52001	106.5	35	30	20	4-Schlitz
W20G02ZL40	82-52001	111.5	40	35	20	
W20G02ZL60	82-52001	131.5	60	55	20	
W20G02ZL80	82-52001	151.5	80	75	20	
W20G03ZL35	82-52002	106.5	35	30	20	
W20G03ZL40	82-52002	111.5	40	35	20	
W20G03ZL45	82-52002	116.5	45	40	20	
W20G03ZL50	82-52002	121.5	50	45	20	
W20G03ZL55	82-52002	126.5	55	50	20	
W20G03ZL60	82-52002	131.5	60	55	20	
W20G03ZL80	82-52002	151.5	80	75	20	

Für grössere Mengen und für andere Ausführungen kontaktieren Sie bitte unseren Verkauf
Tel: +41 61 935 93 00, verkauf@fabry.ch, www.fabry.ch

Spezifikation
Glockenzangen



FABRY AG
SPANNZANGEN-TECHNOLOGIE
CNC-Bearbeitung Drehen Fräsen Schleifen

Glockenspannzangen Typ W25G



Einheitsnummer -

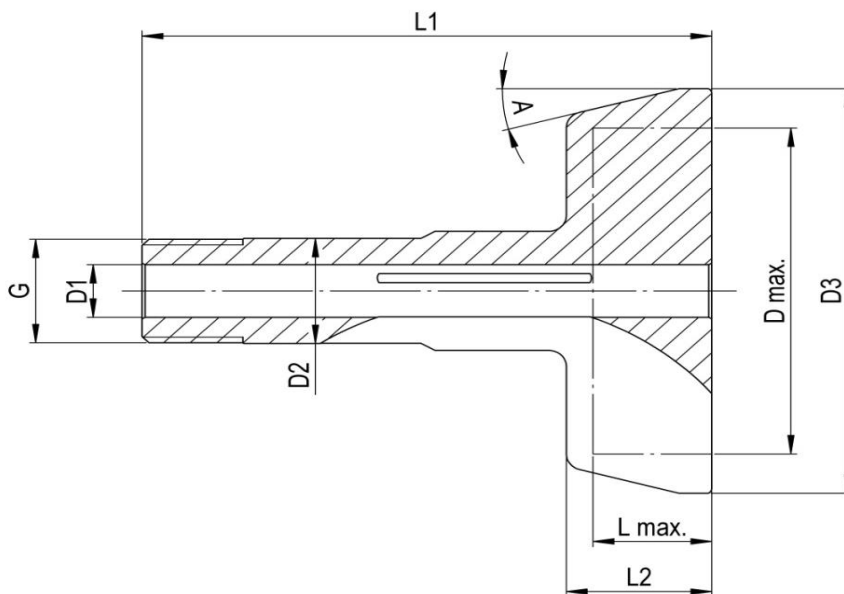

Abmessungen	D1	D2	D3	A	G
W25G01	ø10.5	ø25	56	15°	ø24.7 x 1.693 - 45°/5°
W25G02	ø10.5	ø25	88	15°	ø24.7 x 1.693 - 45°/5°
W25G03	ø10.5	ø25	120	15°	ø24.7 x 1.693 - 45°/5°
W25G04	ø10.5	ø25	150	15°	ø24.7 x 1.693 - 45°/5°
W25G05	ø10.5	ø25	182	15°	ø24.7 x 1.693 - 45°/5°

Fabry Bestell Nr:	Alte-Nr.	L1	L2	L max.	D max.	Bemerkungen
Standard						
W25G01	82-51011	120	24.5	20	ø40	
W25G01SA4	82-51011	120	24.5	20	ø40	4-Schlitz
W25G02	82-51012	120	24.5	20	ø72	
W25G02SA4	82-51012	120	24.5	20	ø72	4-Schlitz
W25G03	82-51013	120	24.5	20	ø104	
W25G04	82-51014	122.5	27	22	ø132	
W25G05	82-51015	122.5	27	22	ø165	

Für grössere Mengen und für andere Ausführungen kontaktieren Sie bitte unseren Verkauf
Tel: +41 61 935 93 00, verkauf@fabry.ch, www.fabry.ch



Einsätze

original Fabry



Einheitsnummer -

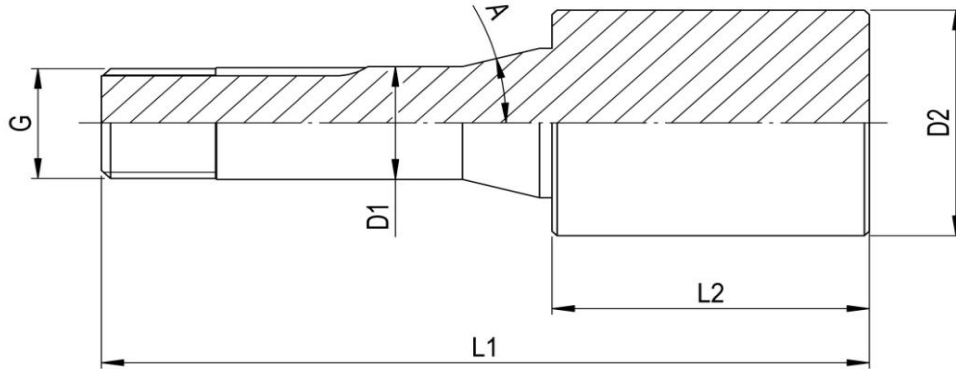

Abmessugen	D1	A	G
W10E	ø10	15°	ø9.83 x 0.833 - 45°/5°
W12E	ø12	15°	ø11.75 x 1.25 - 45°/5°
W15E	ø15	15°	ø14.75 x 1.25 - 45°/5°
W20E	ø20	15°	ø19.7 x 1.667 - 45°/5°
W25E	ø25	15°	ø24.7 x 1.693 - 45°/5°

Fabry Bestell Nr:	SV-Nr.	Bohrung Form	L1	L2	D2	Bemerkungen
W10E...ZL...	83-50001	ø 14.20 x 40.00				
		ø 14.20 x 80.00				
		ø 20.00 x 40.00				
		ø 25.00 x 40.00				
		ø 30.00 x 40.00				
		ø 40.00 x 40.00				
		ø 50.00 x 40.00				
W12E...ZL...	83-50003	ø 20.00 x 40.00				
		ø 20.00 x 100.00				
		ø 25.00 x 40.00				
		ø 25.00 x 100.00				
		ø 30.00 x 40.00				
		ø 30.00 x 100.00				
		ø 40.00 x 40.00				
		ø 40.00 x 100.00				
		ø 50.00 x 13.00				
		ø 50.00 x 40.00				
		ø 60.00 x 40.00				
W15E...ZL...	83-50005	ø 20.00 x 50.00				
		ø 20.00 x 100.00				
		ø 30.00 x 50.00				
		ø 30.00 x 100.00				

Tel: +41 61 935 93 00, verkauf@fabry.ch

W20E...ZL...	83-50007	∅ 30.00 x 50.00				
		∅ 30.00 x 100.00				
		∅ 30.00 x 150.00				
		∅ 30.00 x 200.00				
		∅ 30.00 x 300.00				
		∅ 35.00 x 50.00				
		∅ 35.00 x 100.00				
		∅ 35.00 x 150.00				
		∅ 35.00 x 200.00				
		∅ 40.00 x 50.00				
		∅ 40.00 x 100.00				
		∅ 40.00 x 150.00				
		∅ 40.00 x 200.00				
		∅ 40.00 x 300.00				
		∅ 50.00 x 50.00				
		∅ 50.00 x 100.00				
		∅ 60.00 x 50.00				
		∅ 60.00 x 100.00				
		∅ 60.00 x 120.00				
		∅ 60.00 x 150.00				
		∅ 70.00 x 100.00				
		∅ 80.00 x 50.00				
		∅ 80.00 x 100.00				
		∅ 100.00 x 30.00				
		∅ 100.00 x 40.00				
		∅ 100.00 x 50.00				
		∅ 100.00 x 70.00				
		∅ 100.00 x 100.00				
W25E...ZL...	83-50009	∅ 40.00 x 50.00				
		∅ 40.00 x 100.00				
		∅ 50.00 x 50.00				
		∅ 50.00 x 100.00				
		∅ 60.00 x 50.00				
		∅ 60.00 x 100.00				
		∅ 60.00 x 150.00				
		∅ 70.00 x 50.00				
		∅ 70.00 x 100.00				
		∅ 80.00 x 50.00				
		∅ 80.00 x 100.00				
		∅ 100.00 x 50.00				
		∅ 100.00 x 100.00				

Für grössere Mengen und für andere Ausführungen kontaktieren Sie bitte unseren Verkauf

Tel: +41 61 935 93 00, Fax: +41 61 935 93 05, verkauf@fabry.ch, www.fabry.ch

**Spezifikation
Spreizdorne**



FABRY AG
 SPANNZANGEN-TECHNOLOGIE
 CNC-Bearbeitung Drehen Fräsen Schleifen

Spreizdorne Typ W25



Einheitsnummer -

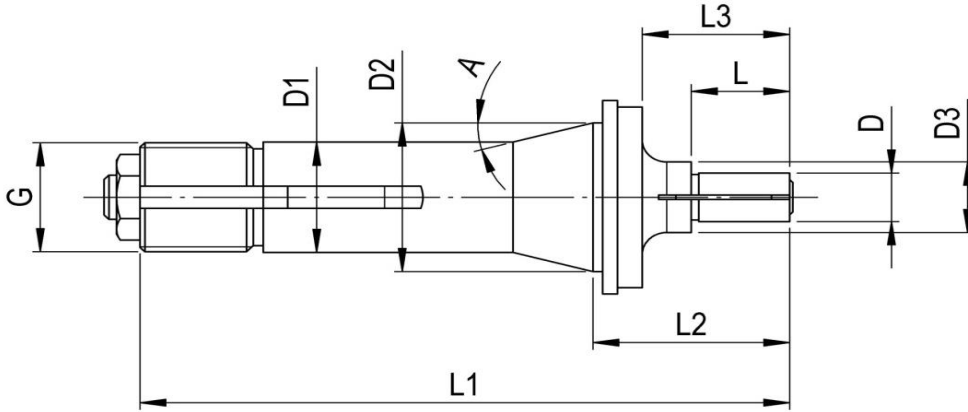

Abmessugen	D1	D2	A	G
W25SD..	ø25	ø33.7	15°	ø24.7x1.693 - 45°/5°

Fabry Bestell Nr:	Alte-Nr.	D	Stufung	D3	L	L1	L2	L3
W25SD..	84-52300	ø 04.00...05.00	0.5	10	12	126	34	24
		ø 05.50...06.00	0.5	122	15	127	35	25
		ø 06.50...08.00	0.5	16	15	127	35	25
		ø 08.50...10.00	0.5	16	15	127	35	25
		ø 10.50...13.00	0.5	16	20	132	40	30
		ø 13.50...17.00	0.5	20	25	137	45	35
		ø 17.50...21.00	0.5	24	30	142	50	40
		ø 21.50...25.00	0.5	28	35	147	55	45
		ø 25.50...29.00	0.5	32	40	152	60	50
		ø 29.50...33.00	0.5	36	45	152	60	50
		ø 33.50...39.00	0.5	-	50	153	61	-
		ø 39.50...41.00	0.5	-	50	153	61	-

Lieferbare Varianten		D						
W25SD..	84-52300	ø 04.00...41.00	0.01					

Für grössere Mengen und für andere Ausführungen kontaktieren Sie bitte unseren Verkauf
 Tel: +41 61 935 93 00, verkauf@fabry.ch, www.fabry.ch



Einsätze W12 / W15 / W20 / W25



Einheitsnummer -

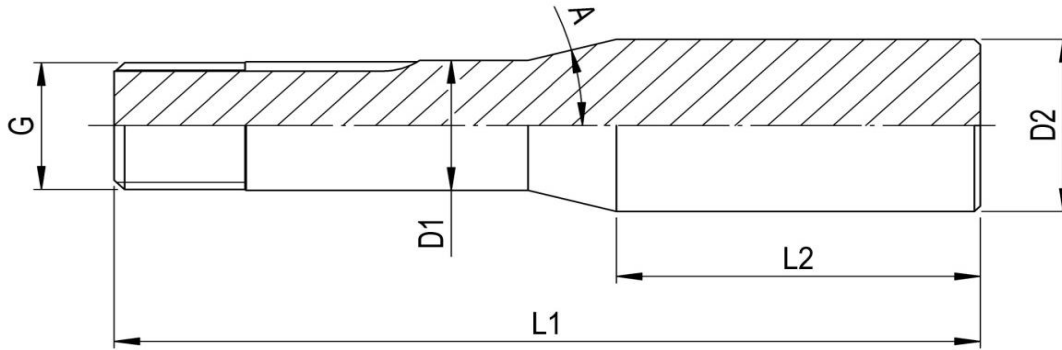

Abmessugen	D1	A	G
W12E	ø12	15°	ø11.75 x 1.25 - 45°/5°
W15E	ø15	15°	ø14.75 x 1.25 - 45°/5°
W20E	ø20	15°	ø19.7 x 1.667 - 45°/5°
W25E	ø25	15°	ø24.7 x 1.693 - 45°/5°

Fabry Bestell Nr:	Alte-Nr.	Bohrung Form	L1	L2	D2	Bemerkungen
W12E...ZL...	83-50002	ø 16.20 x 40.00	84.30	40.00	16.20	
		ø 16.20 x 100.00	144.3	100.00	16.20	
W15E...ZL...	83-50004	ø 20.00 x 50.00	106.3	50.00	20.00	
		ø 20.00 x 100.00	156.3	100.00	20.00	
W20E...ZL...	83-50006	ø 26.30 x 200.00	256.3	200.00	26.30	
		ø 26.50 x 100.00	170.6	100.00	26.50	
		ø 26.50 x 150.00	226.6	150.00	26.50	
		ø 26.50 x 20.00	91	20.00	26.50	
		ø 26.50 x 50.00	120.6	50.00	26.50	
W25E...ZL...	83-50008	ø 33.90 x 50.00	144.3	50.00	33.90	
		ø 33.90 x 100.00	194.3	100.00	33.90	
		ø 33.90 x 200.00	294.3	200.00	33.90	

Für grössere Mengen und für andere Ausführungen kontaktieren Sie bitte unseren Verkauf
Tel: +41 61 935 93 00, verkauf@fabry.ch, www.fabry.ch



Einsätze W20 verdickt



Einheitsnummer -

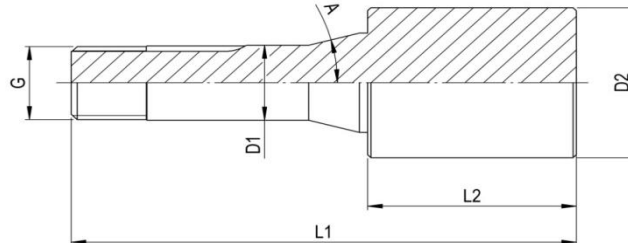

Abmessugen	D1	A	G
W20E	ø20	15°	ø19.7 x 1.667 - 45°/5°

Fabry Bestell Nr:	Alte-Nr.	Bohrung Form	L1	L2	D2	Bemerkungen
W20E...ZL...	83-50007	ø 30.00 x 50.00	120.6	50	30	
		ø 30.00 x 100.00	170.6	100	30	
		ø 30.00 x 150.00	220.6	150	30	
		ø 30.00 x 200.00	270.6	200	30	
		ø 30.00 x 300.00	370.6	300	30	
		ø 35.00 x 50.00	120.6	50	35	
		ø 35.00 x 100.00	170.6	100	35	
		ø 35.00 x 150.00	220.6	150	35	
		ø 35.00 x 200.00	270.6	200	35	
		ø 40.00 x 50.00	120.6	50	40	
		ø 40.00 x 100.00	170.6	100	40	
		ø 40.00 x 150.00	220.6	150	40	
		ø 40.00 x 200.00	270.6	200	40	
		ø 40.00 x 300.00	370.6	300	40	
		ø 50.00 x 50.00	120.6	50	50	
		ø 50.00 x 100.00	170.6	100	50	
		ø 60.00 x 50.00	120.6	50	60	
		ø 60.00 x 100.00	170.6	100	60	
		ø 60.00 x 120.00	190.6	120	60	
		ø 60.00 x 150.00	220.6	150	60	
		ø 70.00 x 100.00	170.6	100	70	
		ø 80.00 x 50.00	120.6	50	80	
		ø 80.00 x 100.00	170.6	100	80	
		ø 100.00 x 30.00	100.6	30	100	
		ø 100.00 x 40.00	110.6	40	100	
		ø 100.00 x 50.00	120.6	50	100	
		ø 100.00 x 70.00	140.6	70	100	
		ø 100.00 x 100.00	170.6	100	100	

Tel: +41 61 935 93 00, verkauf@fabry.ch, www.fabry.ch
Tel: +41 61 935 93 00, Fax: +41 61 935 93 05, verkauf@fabry.ch, www.fabry.ch



Einsätze B6 / B8 / B15 / B32



Einheitsnummer -

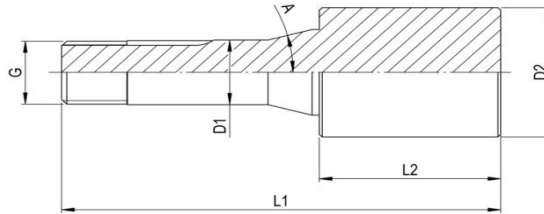

Abmessugen	D1	A	G
B6E	ø6	20°	ø 5.0x0.706 - 55°
B8E	ø8	20°	ø 6.82x0.625 - 55°
B15E	ø15	20°	M13x1
B32E	ø32	20°	ø 29.7x15f - 45°/5°

Fabry Bestell Nr:	Alte-Nr.	Bohrung Form	L1	L2	D2	Bemerkungen
B6E...ZL...	83-10003	ø 10.70 x 40.00	70.8	40	10.7	
		ø 15.00 x 40.00	70.8	40	15	
		ø 20.00 x 40.00	70.8	40	20	
		ø 30.00 x 40.00	70.8	40	30	
B8E...ZL...	83-10005	ø 13.20 x 40.00	73.8	40	13.2	
		ø 13.20 x 75.00	108.8	75	13.2	
		ø 13.20 x 100.00	133.8	100	13.2	
		ø 16.00 x 75.00	103.8	70	16	
		ø 16.00 x 100.00	133.8	100	16	
		ø 20.00 x 20.00	53.8	20	20	
		ø 20.00 x 40.00	73.8	40	20	
		ø 20.00 x 75.00	108.8	75	20	
		ø 20.00 x 100.00	133.8	100	20	
		ø 25.00 x 40.00	73.8	40	25	
		ø 30.00 x 40.00	73.8	40	30	
		ø 40.00 x 40.00	73.8	40	40	
B15E...ZL...	83-10007	ø 25.00 x 40.00	93.5	40	25	
		ø 30.00 x 40.00	93.5	40	30	
B32E...ZL...	83-10001	ø 50.00 x 50.00	152	50	50	
		ø 50.00 x 100.00	202	100	50	
		ø 60.00 x 50.00	152	50	60	
		ø 60.00 x 100.00	202	100	60	
		ø 80.00 x 50.00	152	50	80	
		ø 80.00 x 100.00	202	100	80	
		ø 100.00 x 50.00	152	50	100	
		ø 100.00 x 100.00	202	100	100	

Tel: +41 61 935 93 00, verkauf@fabry.ch, www.fabry.ch
 Tel: +41 61 935 93 00, Fax: +41 61 935 93 05, verkauf@fabry.ch, www.fabry.ch

Spezifikation
Spannzangen



FABRY AG
SPANNZANGEN-TECHNOLOGIE
CNC-Bearbeitung Drehen Fräsen Schleifen

Einsätze P6 / P10 / P16



Einheitsnummer -

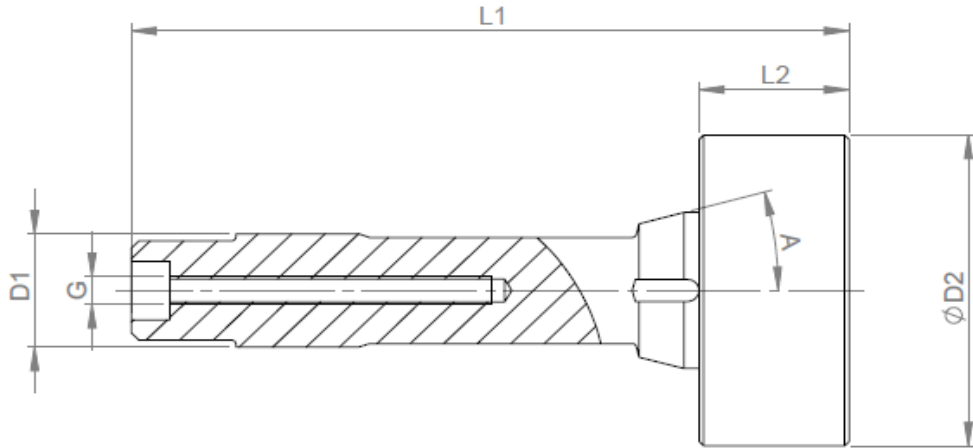

Abmessugen	D1	A	G
P6E	ø6	15°	M4
P10E	ø10	15°	M7
P16E	ø16	15°	M8

Fabry Bestell Nr:	Alte-Nr.	Bohrung Form	L1	L2	D2	Bemerkungen	
P6E...ZL...	83-40003	ø 12.00 x 25.00	52	25	12		
		ø 15.00 x 25.00	52	25	15		
		ø 25.00 x 25.00	52	25	25		
P10E...ZL...	83-40001	ø 14.20 x 20.00	58	20	14.2		
		ø 14.20 x 40.00	78	40	14.2		
		ø 20.00 x 20.00	58	20	20		
		ø 20.00 x 40.00	78	40	20		
		ø 25.00 x 20.00	58	20	25		
		ø 25.00 x 40.00	78	40	25		
		ø 30.00 x 20.00	58	20	30		
P16E...ZL...	83-40006	ø 40.00 x 20.00	96	20	40		
		ø 50.00 x 20.00	96	20	50		

Für grössere Mengen und für andere Ausführungen kontaktieren Sie bitte unseren Verkauf
Tel: +41 61 935 93 00, verkauf@fabry.ch, www.fabry.ch

Reduktion der Rüstzeit

durch das

FABRY - Schnellspannsystem für F - Spannzangen

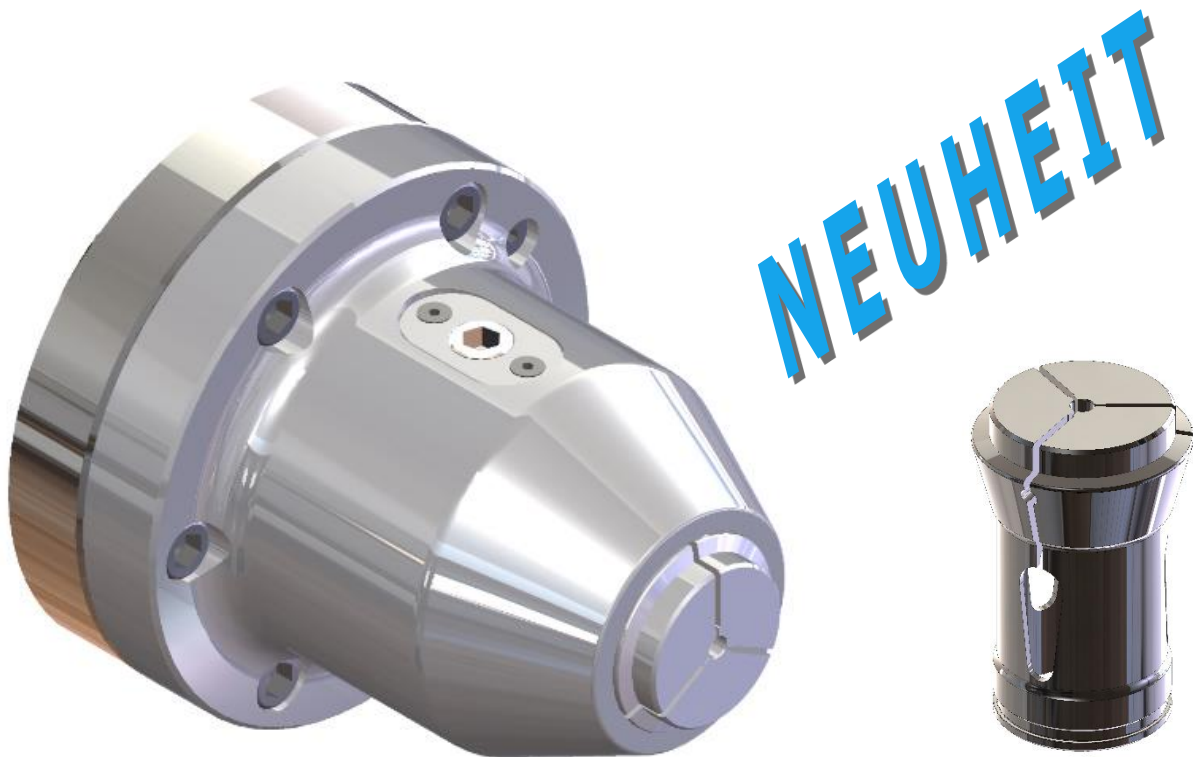

Besondere Merkmale:

- Sekundenschnelle Verriegelung nur durch das Einschieben
- Schnelle Entriegelung durch $\frac{1}{4}$ -Drehung mit dem 6-kt-Schlüssel
- Mit leichter Anpassung ist die Verwendung der Standard F-Spannzangen möglich
 - Voller Durchgang der Spannbohrung
 - Späneschutz während der Bearbeitung
 - Aufnahme-Adapter für andere Spann-Systeme möglich

Spannzangenanschlag mit Kugeln

Diese Vorrichtung ermöglicht auf einfache Weise die Serienherstellung von Teilen in fixer Länge.

Der Anschlagstift ist in der Tiefe verstellbar und kann im Durchmesser angedreht werden.

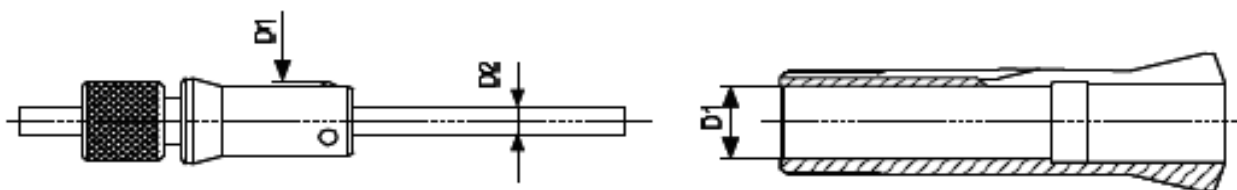

Bestell-Nr.	D1 min. bis max.	D2	Für Spannzangen Typ	
68-99100	3.90 - 4.40	1.2	B8	F6
68-99101	4.50 - 5.40	1.2		F7
68-99102	5.40 - 6.60	1.5		F7/F8
68-99103	6.50 - 7.40	2		F9/F10
68-99104	8.00 - 8.80	2.5		
68-99105	9.30 - 10.90	2.5	B15	F12/F13/F14/F15
68-99106	12.00 - 13.80	2.5		F16
68-99107	13.50 - 15.10	5		F17.46/F18
68-99108	15.00 - 16.80	5	B32	
68-99109	16.40 - 18.20	7	B32	F20/F22/F23.8
68-99110	16.50 - 19.95	5		
68-99111	19.80 - 22.80	7		F25/F26
68-99112	22.00 - 23.80	7		F27/F28
68-99113	23.00 - 24.80	7	B32	
68-99114	24.60 - 27.80	7		F30/F32
68-99115	27.60 - 30.80	7		F34/F35
68-99116	30.00 - 33.80	7		F38
68-99117	34.80 - 40.70	10	B45	F42
68-99118	39.80 - 44.70	10		F48
68-F58	51.00 - 53.80			F58
68-F64	54.00 - 57.80			F64
68-F66	59.00 - 62.80			F66

Gefederte Auswerfer passend zu den Spannzangenanschlägen sind auf Anfrage erhältlich.

Für grössere Mengen und für andere Ausführungen kontaktieren Sie bitte unseren Verkauf

Tel: +41 61 935 93 00, verkauf@fabry.ch, www.fabry.ch



Spannzangenanschlag CG

Kompletter Satz auf Aluminiumsockel (blau) in 2 Varianten.
Als Grundausführung für Spannzangen Typ **W 20** und **W 25**.

Reduktionshülsen sind lieferbar für:

Zusatzhülse von W20 auf **F27**

Zusatzhülse von W25 auf **B32**

Zusatzhülse von W25 auf **F38**

Zusatzhülse von W25 auf **F48**



Vorteile sind:

Stabile Fixierung in der Zange (ohne Zangenverzug).

Der Anschlag kann in der Zange bearbeitet werden,
was einen sehr genauen Plan- und Rundlauf gewährleistet.

Auch eine Indexierung des Werkstückes kann eingepasst werden.

Für grössere Mengen und für andere Ausführungen kontaktieren Sie bitte unseren Verkauf

Tel: +41 61 935 93 00, verkauf@fabry.ch, www.fabry.ch

Spannzangenanschlag Moser

Dieses universelle Anschlagssystem für F-Spannzangen bringt Zeitersparnis und Anschlagssicherheit und erfüllt die Wünsche der praktischen Anwendbarkeit in höchstem Masse.

Präzise Einstell- und Arretiertechnik garantiert die Einhaltung der gewünschten Anschlagmasse. Dadurch werden Ausschuss-Drehteile in diesem Bereich eliminiert.



Sie erhalten das System als Universalset im zweckmässigen Holzkoffer mit sämtlichen, für jeden Spannzangendurchmesser korrekten, Anschlagtellern.

Alle Einzelteile sind separat erhältlich.

Lieferbar in den Ausführungen für:

**Spannzangen F32
Spannzangen F35
Spannzangen F38
Spannzangen F48
Spannzangen F66**

Für grössere Mengen und für andere Ausführungen kontaktieren Sie bitte unseren Verkauf

Tel: +41 61 935 93 00, verkauf@fabry.ch, www.fabry.ch



Führungsbüchsen Hartmetall Canon

Serge Meister

Type	Canon typ A / B / Inter / Tournant							Alésage min.			Alésage max.		
	No. Art.	Fournisseurs / Supplier		dimension extérieur / outside				φ min. / min. bore			φ max. / max. bore		
	Art. Nr.	Hersteller / Proveedor		Aussen Masse / medida de fuera				min. Bohrung / taladro min.			max. Bohrung / taladro max.		
	Meister Swiss	Neukomm	Dünner	φ	L	M	β	d min.	6pans	carré	d max.	6pans	carré
B	600	51.001 / 200		7.0	29.0	6 x 0.5	30°	0.31	1.0	1.0	4.0	3.5	2.5
I	1601	50.001	J 2	7.0	30.0	6 x 0.5	16°	0.31	1.0	1.0	3.5	3.0	2.5
A	451	2.001	1002	9.0	30.0		19°	0.31	1.0	1.0	4.0	3.5	2.5
B	351	150	B201	9.0	50.0	8 x 0.6	30°	0.31	1.0	1.0	5.0	4.5	2.5
B	600S	60.001	B242	9.0	26.0	6 x 0.5	30°	0.31	1.0	1.0	4.5	4.0	3.0
I	1351	51.001 / 200	J 3	9.0	44.0	8 x 0.75	16°	0.31	1.0	1.0	5.0	4.5	3.0
A	453	6.001	1004	11.0	30.0		19°	0.50	1.0	1.0	6.5	5.5	4.5
B	352	5.001		11.0	50.0	10 X 0.6	30°	0.50	1.0	1.0	7.5	6.0	4.0
I	1352	3.001 / 203	J 4	11.0	53.0	10 X 0.8	16°	0.50	1.0	1.0	7.5	6.0	5.0
B	103		B211	12.0	50.0	12 X 1.0	30°	0.50	1.0	1.5	8.0	6.5	5.5
I	1603	53.001	J 5	12.0	50.0	10 X 0.75	16°	0.50	1.0	1.5	7.5	6.0	5.0
T	3400T	113.001 / 10	B300	13.0	41.5	12.5X0.75	15°	0.70	1.0	1.5	8.0	7.0	5.0
T	3300T	207 / 50	B304	14.0	64.0	13 X 0.75	16°	0.70	1.0	1.5	8.0	7.0	5.5
A	203	104.001	1024	16.0	40.0	30°	30°	0.70	1.0	1.5	8.0	7.0	5.5
A	457	9.001	1008	16.0	30.0		19°	0.70	1.5	1.5	10.0	8.0	7.0
B	603		B203	16.0	61.0	15 X 1.0	30°	0.70	1.5	1.5	11.0	9.5	8.0
I	1353	8.001 / 206	J 6 R	16.0	59.0	14 X 1.0	16°	0.70	1.5	1.5	10.5	9.0	7.5
I	1604	54.001 / 103	J 6	16.0	59.0	14 X 1.0	16°	0.70	1.5	1.5	10.5	9.0	7.5
B	353			17.0	61.0	15 X 1.0	30°	1.00	1.5	2.0	12.0	10.0	8.0
B	853	166.001 / 208	B212A	18.0	59.0	16 X 1.0	30°	1.00	1.5	2.0	13.0	11.0	9.0
T	Top 100			18.0	100.0	18 X 1.0	20°	1.00	1.5	3.0	13.0	11.0	9.0
A	204	105.001	1025	20.0	40.0	30°	30°	1.00		2.0	11.0	9.0	7.5
B	104		B208	20.0	55.0	20 X 1.0	30°	1.00	1.5	2.0	13.0	11.0	9.0
T	221T	450.001 / 800	B301	21.0	57.5	18 X 1.0	12°	1.50	2.0	2.0	11.0	9.5	8.0
I	1354	13.001	J 7 A	22.0	68.0	19 X 1.0	16°	1.50	2.0	2.0	16.0	14.0	11.0
T	39001T	39.001	J 7 AR	22.0	68.0	22 X 1.0	16°	1.50	2.0	2.0	18.0	15.0	13.0
A	459	15.001	1010	24.0	42.0		19°	1.50	2.0	2.0	15.0	13.0	10.0
B	605	61.002 / 106	B238	24.0	61.0	24 X 1.0	30°	1.50	2.0	2.0	16.0	14.0	11.0
B	354		B213	25.0	63.0	25 X 1.0	30°	2.00	2.0	3.0	18.0	15.0	13.0
T	3402T	13	B302	27.0	57.5	24 X 1.0	12°	2.00	2.5	3.0	16.0	14.0	11.0
A	460	16.001	1011	28.0	45.0		29°	2.00	2.5	3.0	20.0	17.0	14.0
I	1357	18.001	B260	28.0	81.0	25 X 1.0	30°	2.00	2.5	3.0	21.0	18.0	15.0
T	223T	22.001	B261	28.0	82.0	25 X 1.0	16°	2.00	2.5	3.0	21.0	18.0	15.0
A	205	107.001	1026	30.0	60.0	29°	29°	2.50	2.5	3.0	17.0	14.0	12.0
A	461	17.001	1012	32.0	45.0		19°	2.50	3.0	3.0	22.0	19.0	15.0
B	355	110	B214	32.0	71.0	32 X 1.0	30°	2.50	2.5	3.0	22.0	19.0	15.0
A	206	108.001	1027	34.0	60.0	29°	29°	2.50	3.0	3.0	22.0	19.0	15.0
T	227T	451.001 / 227	B227	34.0	87.5	34 X 1.0	10°	2.50	3.0	4.0	25.0	22.0	18.0
T	Top 200	Top 200		34.0	150.0	32 X 1.5	20°	3.00	3.0	4.0	26.0	22.0	18.0
A	462	20.001	1013	38.0	45.0		19°	3.00	3.0	4.0	28.0	24.0	19.0
A	463	21.001	1030	38.0	60.0		19°	3.00	3.0	4.0	28.0	24.0	19.0
B	105	61.001	B207	40.0	71.0	40 X 1.0	30°	3.00	3.0	4.0	30.0	26.0	20.0
B	854	172.001	B207 A	40.0	72.0	36 X 1.0	30°	3.00	4.0	4.0	26.0	22.0	20.0
A	207	110.001	1028	42.0	72.0	29°	29°	3.00	4.0	4.0	26.0	22.0	20.0
A	465	29.001	1032	42.0	60.0		19°	3.00	4.0	4.0	28.0	24.0	20.0
T	229T	28.001 / 229	J 9	42.0	82.0	40 X 1.0	16°	4.00	4.0	4.0	32.0	26.0	20.0
I	1355	27.001	J 10	44.0	87.0	40 X 1.0	20°	4.00	4.0	4.0	32.0	26.0	20.0
A	464	30.001	1031	46.0	60.0		19°	4.00	4.0	4.0	32.0	26.0	20.0
A	208	111.001	1029	48.0	72.0	29°	29°	4.00	4.0	4.0	28.0	26.0	18.0

Für grössere Mengen und für andere Ausführungen kontaktieren Sie bitte unseren Verkauf

Tel: +41 61 935 93 00, verkauf@fabry.ch, www.fabry.ch

Spezifikation
Vorschubzangen



FABRY AG

SPANNZANGEN-TECHNOLOGIE
CNC-Bearbeitung Drehen Fräsen Schleifen

Vorschubzangen

FAB

Einheitsnummer -

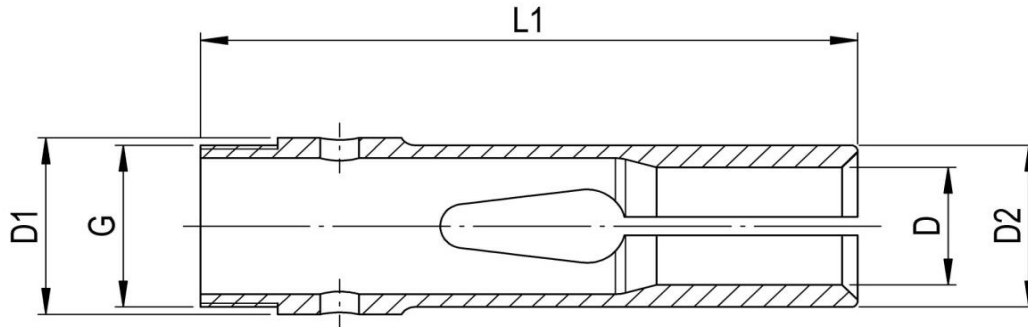

Faby

Best. Nr:	Alte-Nr.	D1	Bohrung Form	Stufung	D2	L1	G
A17.9D..	71-00335	17.9	∅ 03.00...14.00	0.5	17.5	70	M16x0.75
	71-00213	17.9	Zangen-Körper		17.5	70	M16x0.75
A18D..	71-00166	18	Restposten	0.5	16	70	M16x1 links
A22.8D..	71-01922	22.8	∅ 04.00...17.00	0.5	20.5	98	M20x0.75
	71-02011	22.8	Zangen-Körper		20.5	98	M20x0.75
A24D..	71-00171	24	Restposten	0.5	22	85	M22x1 links
A30D..	71-00181	30	Restposten	0.5	29	95	M28x1 links
A31D..	7100176	31	Restposten	0.5	29	90	M29x1 links
A32.4D..	71-00177	32.4	Restposten	0.5	30	154	M30x1 links
A42D...	71-00184	42	Restposten	0.5	40	116	M40x1 links
A56D..	71-00187	56	Restposten	0.5	54	136	M50x1 links
A60D..	71-00230	60	Restposten	0.5	58	140	M58x1 links

Für grössere Mengen und für andere Ausführungen kontaktieren Sie bitte unseren Verkauf

Tel: +41 61 935 93 00, verkauf@fabry.ch, www.fabry.ch

**Spezifikation
Zangen für
Stangenlader**



FABRY AG

SPANNZANGEN-TECHNOLOGIE
CNC-Bearbeitung Drehen Fräsen Schleifen

Serie 9100 - 9110

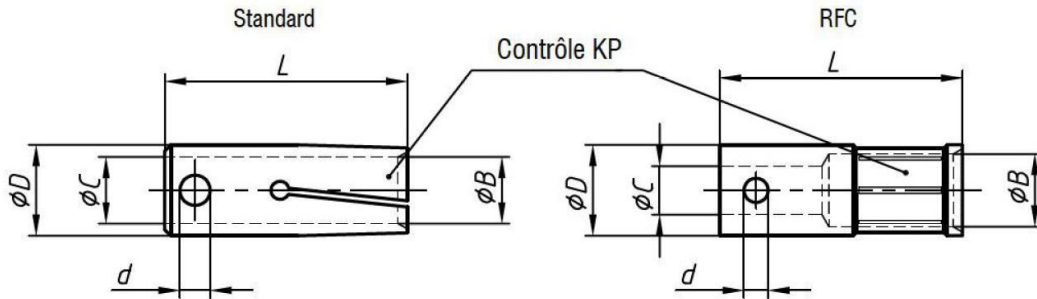

FMB - TRAUB - HAGENUK - IEMCA - ROBOBAR - LNS - SAMECA
MINISPRINT - MINITURBO

No de cde Bestell Nr Order Nr	Ø D mm	Standard	RFC	Ecart Abstand Distance mm	Ø C mm	L mm	d
		Alésage Bohrung Bore Ø B mm	Alésage Bohrung Bore Ø B mm				
9100.0000	7	2 - 5,5	—	0,10 - 0,10	M5	37	-
9100.0001	7	—	5,6 - 6	0,10 - 0,10	M5	37	-
9101.0000	10	3 - 8	—	0,10 - 0,10	7	40	2 x Ø 4
9101.0001	10	—	8,1 - 8,5	0,10 - 0,10	7	40	2 x Ø 4
9102.0000	12	4 - 10	—	0,10 - 0,10	8	40	2 x Ø 4
9102.0001	12	—	10,1 - 10,5	0,10 - 0,10	8	40	2 x Ø 4
9103.0000	15	7 - 13	—	0,10 - 0,10	11	40	2 x Ø 6
9103.0001	15	—	13,1 - 13,5	0,10 - 0,10	11	40	2 x Ø 6
9104.0000	16	8 - 14	—	0,10 - 0,10	11	40	2 x Ø 6
9104.0001	16	—	14,1 - 14,5	0,10 - 0,10	11	40	2 x Ø 6
9105.0000	18	8 - 15,5	—	0,10 - 0,10	11	40	2 x Ø 6
9105.0001	18	—	15,6 - 16	0,10 - 0,10	11	40	2 x Ø 6
9106.0000	20	10 - 17,5	—	0,10 - 0,10	14	65	2 x Ø 8
9106.0001	20	—	17,6 - 18	0,10 - 0,10	14	65	2 x Ø 8
9107.0000	25	15 - 22,5	—	0,50 - 0,50	20	65	2 x Ø 8
9107.0001	25	—	22,6 - 23	0,50 - 0,50	20	65	2 x Ø 8
9108.0000	30	20 - 27,5	—	0,50 - 0,50	20	65	2 x Ø 8
9108.0001	30	—	27,6 - 28	0,50 - 0,50	20	65	2 x Ø 8
9109.0000	32	20 - 29	—	0,50 - 0,50	20	65	2 x Ø 8
9109.0001	32	—	29,1 - 30	0,50 - 0,50	20	65	2 x Ø 8
9110.0000	34	20 - 31	—	0,50 - 0,50	20	90	2 x M6
9110.0001	34	—	31,1 - 32	0,50 - 0,50	20	90	2 x M6
9111.0000	36	20 - 33	—	0,50 - 0,50	20	90	2 x M8
9111.0001	36	—	33,1 - 34	0,50 - 0,50	20	90	2 x M8
9112.0000	38	20 - 35	—	0,50 - 0,50	20	90	2 x M8
9112.0001	38	—	35,1 - 36	0,50 - 0,50	20	90	2 x M8
9113.0000	40	20 - 37	—	0,50 - 0,50	20	90	2 x M8
9113.0001	40	—	37,1 - 38	0,50 - 0,50	20	90	2 x M8
9114.0000	42	20 - 39	—	0,50 - 0,50	20	90	2 x M8
9114.0001	42	—	39,1 - 40	0,50 - 0,50	20	90	2 x M8

Für grössere Mengen und für andere Ausführungen kontaktieren Sie bitte unseren Verkauf

Tel: +41 61 935 93 00, verkauf@fabry.ch, www.fabry.ch

**Spezifikation
Zangen für
Stangenlader**



FABRY AG

SPANNZANGEN-TECHNOLOGIE
CNC-Bearbeitung Drehen Fräsen Schleifen

Serie 9110 - 9120

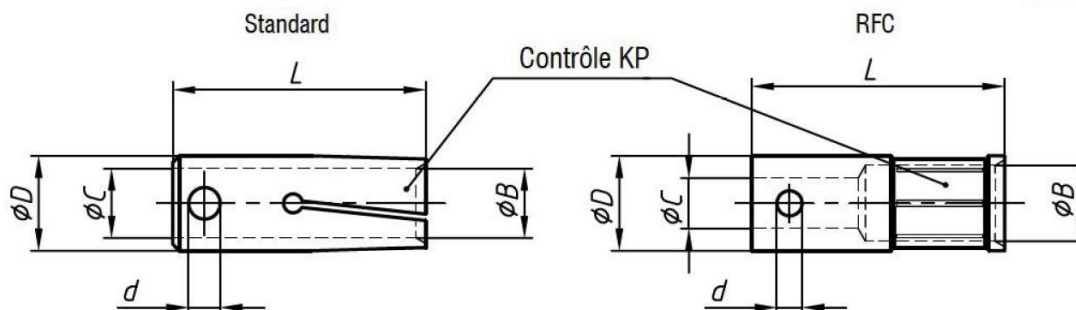

FMB - TRAUB - HAGENUK - IEMCA - ROBOBAR - LNS - SAMECA
MINISPRINT - MINITURBO

Dimensions spéciales
Spezial Ausmass
Special sizes

No de cde Bestell Nr Order Nr	$\varnothing D$ mm	Standard		RFC		Ecart Abstand Distance mm	$\varnothing C$ mm	L mm	d
		Alésage Bohrung Bore mm	$\varnothing B$ mm	Alésage Bohrung Bore mm	$\varnothing B$ mm				
9115.0000	5	1,5 - 4	—	—	—	0,10 - 0,10	M4	37	-
9117.0000	13	4 - 11	—	—	—	0,50 - 0,50	8	40	2 x $\varnothing 4$
9117.0001	13	—	—	11,1 - 11,5	—	0,50 - 0,50	8	40	2 x $\varnothing 4$
9118.0000	14	5 - 12	—	—	—	0,50 - 0,50	8	40	2 x $\varnothing 4$
9118.0001	14	—	—	12,1 - 12,5	—	0,50 - 0,50	8	40	2 x $\varnothing 4$
9119.0000	17	8 - 15	—	—	—	0,50 - 0,50	11	40	2 x $\varnothing 6$
9119.0001	17	—	—	15,1 - 15,5	—	0,50 - 0,50	11	40	2 x $\varnothing 6$
9120.0000	19	8 - 16,5	—	—	—	0,50 - 0,50	11	40	2 x $\varnothing 6$
9120.0001	19	—	—	16,6 - 17	—	0,50 - 0,50	11	40	2 x $\varnothing 6$
9121.0000	21	12 - 18,5	—	—	—	0,50 - 0,50	14	65	2 x $\varnothing 8$
9121.0001	21	—	—	18,6 - 19	—	0,50 - 0,50	14	65	2 x $\varnothing 8$
9122.0000	22	15 - 19,5	—	—	—	0,50 - 0,50	14	65	2 x $\varnothing 8$
9122.0001	22	—	—	19,6 - 20	—	0,50 - 0,50	14	65	2 x $\varnothing 8$
9123.0000	23	15 - 20,5	—	—	—	0,50 - 0,50	14	65	2 x $\varnothing 8$
9123.0001	23	—	—	20,6 - 21	—	0,50 - 0,50	14	65	2 x $\varnothing 8$
9124.0000	24	15 - 21,5	—	—	—	0,50 - 0,50	14	65	2 x $\varnothing 8$
9124.0001	24	—	—	21,6 - 22	—	0,50 - 0,50	14	65	2 x $\varnothing 8$
9125.0000	26	20 - 23,5	—	—	—	0,50 - 0,50	20	65	2 x $\varnothing 8$
9125.0001	26	—	—	23,6 - 24	—	0,50 - 0,50	20	65	2 x $\varnothing 8$
9126.0000	27	20 - 24,5	—	—	—	0,50 - 0,50	20	65	2 x $\varnothing 8$
9126.0001	27	—	—	24,6 - 25	—	0,50 - 0,50	20	65	2 x $\varnothing 8$
9127.0000	28	20 - 25,5	—	—	—	0,50 - 0,50	20	65	2 x $\varnothing 8$
9127.0001	28	—	—	25,6 - 26	—	0,50 - 0,50	20	65	2 x $\varnothing 8$

Für grössere Mengen und für andere Ausführungen kontaktieren Sie bitte unseren Verkauf

Tel: +41 61 935 93 00, verkauf@fabry.ch, www.fabry.ch

Spezifikation
Zangen für
Stangenlader



FABRY AG

SPANNZANGEN-TECHNOLOGIE
CNC-Bearbeitung Drehen Fräsen Schleifen

Serie 9150 - 9160

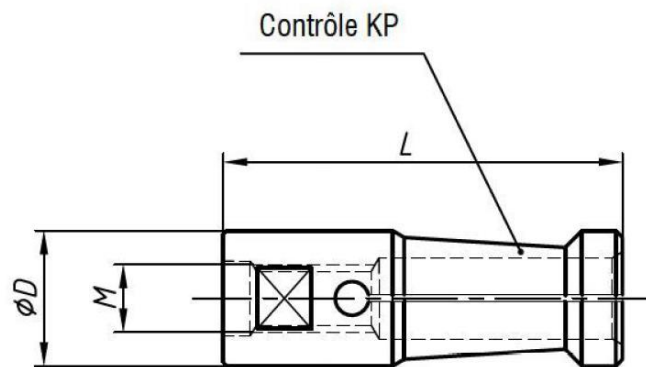

IEMCA AS / CS

No de cde Bestell Nr Order Nr	$\varnothing D$ mm	L mm	M mm
9151.0000	5,5	37	M4 x 0,5
9152.0000	7	40	M5 x 0,5
9153.0000	7,5	40	M5 x 0,5
9155.0000	10	40	M6 x 0,75
9156.0000	12	42	M7 x 0,75
9157.0000	15	42	M8 x 1
9158.0000	16	42	M8 x 1
9160.0000	20	59	M10 x 1
9163.0000	27	59	M10 x 1

Für grössere Mengen und für andere Ausführungen kontaktieren Sie bitte unseren Verkauf

Tel: +41 61 935 93 00, verkauf@fabry.ch, www.fabry.ch

**Spezifikation
Werkzeugspannung**



FABRY AG

SPANNZANGEN-TECHNOLOGIE
CNC-Bearbeitung Drehen Fräsen Schleifen

Werkzeugspannung REGO-FIX

Vertretung gesamtes Sortiment



siehe auch

www.rego-fix.com

Für grössere Mengen und für andere Ausführungen kontaktieren Sie bitte unseren Verkauf

Tel: +41 61 935 93 00, verkauf@fabry.ch, www.fabry.ch

**Spezifikation
Werkzeugspannung**



FABRY AG

SPANNZANGEN-TECHNOLOGIE
CNC-Bearbeitung Drehen Fräsen Schleifen

Werkzeugspannung Schaublin SA

Vertretung gesamtes Sortiment



SCHAUBLIN

siehe auch

www.schaublin.ch

Für grössere Mengen und für andere Ausführungen kontaktieren Sie bitte unseren Verkauf

Tel: +41 61 935 93 00, verkauf@fabry.ch, www.fabry.ch



Drehbankspitzen mit auswechselbaren Einsätzen

Die verschiedenen Spitzenaufnehmer sind mit einem selbsthemmenden 2° - Konus gefertigt, so dass sämtliche Einsatzspitzen gegenseitig auswechselbar sind.

Der Mitnehmerflansch Typ VMF-16 kann auf die Zangeneinsätze und auf feste Spitzenaufnehmer montiert werden und mittels Drehherz ist dieses Werkzeug sehr nützlich für Dreharbeiten, die zwischen den Spitzen ausgeführt werden.

	Rotierende Spitzenaufnehmer mit Morse - Schaft						
	Typ	Best.-Nr.	A	a	B	C	D
	RS / MK 1	7910.01000	25	14	25,5	53,5	MK 1
	RS / MK 2	7910.02000	30	18	28,0	64,0	MK 2
RS / MK 3	7910.03000	40	24	36,0	81,0	MK 3	
	Feste Spitzenaufnehmer mit Morse - Schaft						
	Typ	Best.-Nr.	A		B	C	D
	FS / MK 1	7920.01000	16		14,5	53,5	MK 1
	FS / MK 2	7920.02000	16		24,0	64,0	MK 2
FS / MK 3	7920.03000	16		29,0	80,0	MK 3	
	Zangeneinsatz - Spitzenaufnehmer für Drehbänke						
	Typ	Best.-Nr.	A		B	C	D
	FS / W 12	7930.12000	16		11	44,0	W-12
	FS / W 20	7930.20000	16		11	70,0	W-20
FS / W 25	7930.25000	16		11	95,0	W-25	
	Spitzenauswerfer - Schlüssel						
	Typ	Best.-Nr.				C	D
SAS-9	7991.00000				110,0	25	
	Verstellbarer Mitnehmerflansch, passend auf alle Spitzenaufnehmer FS/MK und FS/W						
	Typ	Best.-Nr.				C	D
VMF-16	7992.00000				78	16	







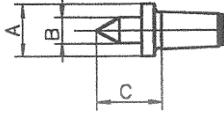

Für grössere Mengen und für andere Ausführungen kontaktieren Sie bitte unseren Verkauf

Tel: +41 61 935 93 00, verkauf@fabry.ch, www.fabry.ch

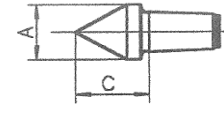
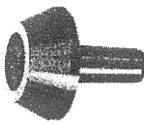
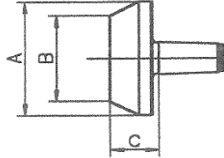

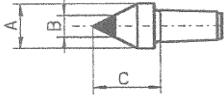
Auswechselbare Einsatzspitzen

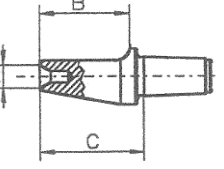
Auswechselbare Einsatzspitzen passend zu allen Spitzenaufnehmern - Konus 2°

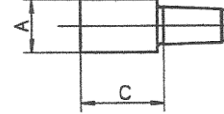
		Einsatzspitzen 60°					
		Bezeichnung	A	B	C		
		AZ / L 4	12.0	4	15		
		AZ / L 6	12.0	6	15		
		AZ / L 12	12.0	--	15		
		AZ / L 15	15.0	--	18		
		ZS / R 16	16.5	9	11		
		ZS / R 18	18.5	11	11		
		ZS / R 20	20.5	13	11		
		ZS / R 22	22.5	15	11		
		ZS / R 24	24.5	17	11		
		ZS / R 26	26.5	19	11		
		ZS / R 28	28.5	21	11		
		ZS / R 30	30.5	23	11		
		ZS / R 35	35.5	26	12		
		ZS / R 40	40.0	31	12		
		ZS / R 45	45.0	36	12		
		ZS / R 50	50.0	41	12		
		ZS / R 55	55.0	46	12		
		ZS / R 60	60.0	51	12		
		mit HM-Spitze					
				AZ / U 6	12.0	6	16
				mit Innenzentrum 60°			
		IZ / T 0,5	0.5	15	19		
		IZ / T 1	1.0	15	19		
		IZ / T 2	2.0	15	19		
		IZ / T 3	3.0	15	19		
		IZ / T 4	4.0	15	19		
		IZ / T 5	5.0	15	19		
		IZ / T 10	10.0	15	19		
		SR / 12 x 19 *	12.0	--	19		
		SR / 30 x 22 *	30.0	--	22		

* Rohling ungehärtet, Werkstoff 100 Cr 6, Konus geschliffen

Für grössere Mengen und für andere Ausführungen kontaktieren Sie bitte unseren Verkauf

Tel: +41 61 935 93 00, verkauf@fabry.ch, www.fabry.ch

Schnellspannhalter

SHG – mit Aussengewinde

Masstabelle

Zugspannzange	H	*	Ø	Nut	TK Ø
W12 318E	70		70	10.2	60 / M8
W20 349E	100 + 40		100	11	85 / M10
W25 364E	125 + 40		100	11	85 / M10

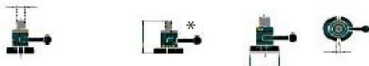

Spannbereich

Ø Zugspannzangen	Ø Glockenzangen	Ø Ringfutter	Ø Spreizdorne
0.3-12.5	22-70	49.2	4-18
0.3-23.0	24-124	75	4-31
0.3-29.0	40-132	96	4-41

(Seiten 33-36)

(Seiten 39-40)

(Seiten 41-42)

Typ

Art. Nr.

SHG 12	4.12.000S
SHG 20	4.20.000S
SHG 25	4.25.000S



Technische Daten

- Korrosionsschutz mit Vergütung des Spannzangenhalters durch Gasnitrieren mit nachträglicher Oxidation

Optionen

- Pneumatische / hydraulische Betätigung siehe Seiten 19 + 20
- Tiefenanschlag siehe Seite 43
- Spannglocke / Spreizring für SHG
- Zugspannzangen Schaublin ab Seite 33



Spannglocke
Außenspannung
(Schaublin 42.1-42.3)

Spreizdorn mit
Spannmutter
(Schaublin 57.1-57.2)

Spreizring
Innenspannung
(Schaublin 46.1-46.2)

SH

Masstabelle

Zugspannzange	H	*	Ø	Nut	TK Ø
B8 302E	60		65	10.2	55 / M8
W10 314E	60		65	10.2	55 / M8
W12 318E	70		70	10.2	60 / M8
W15 3213E	98		78	11	-
W20 349E	100 + 40		100	11	85 / M10
W25 364E	125 + 40		100	11	85 / M10
B32 3713E	125		115	11	97 / M10



Spannbereich

Ø Zugspannzangen	Notfall-Spreizdorn
0.3-10	-
0.3-10	-
0.3-12.5	10-45
0.3-16	-
0.3-23	10-50
0.3-29	15-90
0.3-32	-

(Seiten 33-38)

(Schaublin Seiten 65 + 66)



Typ

Art. Nr.

SB 8	3.08.000S
SH 10	3.10.000S
SH 12	3.12.000S
SH 15	3.15.000
SH 20	3.20.000S
SH 25	3.25.000S
SB 32	3.32.000S



Technische Daten / Optionen

- Siehe oben

Für grössere Mengen und für andere Ausführungen kontaktieren Sie bitte unseren Verkauf

Tel: +41 61 935 93 00, verkauf@fabry.ch, www.fabry.ch